

METAL ROOFING SYSTEMS

Helping you push the building envelope.



BEAUTIFUL. FUNCTIONAL. DURABLE.

STANDING THE TEST OF TIME

For over 85 years, Vicwest has been manufacturing premium quality roofing, metal cladding, and decking in Canada, redefining and setting the standards in metal building construction and design.

With service and manufacturing facilities in Canada and the United States providing expert technical support, you can be confident that, regardless of location, your project will be covered by the Vicwest umbrella. Vicwest is the leader in building envelope systems, providing comprehensive service, support and ultimate reliability.



VICWEST ROOF SYSTEMS

A metal roofing system by Vicwest will add beauty and character to your building's design regardless of size and shape demands and protect it for years to come with unmatched durability.

Vicwest metal roof systems provide the ultimate in design performance. Architecturally attractive and exceptionally functional, they offer the most contemporary designs for commercial, industrial, institutional and residential buildings. Our comprehensive product selection offers a variety of steel substrates, finishes, and profiles protected by technologically advanced 40-year coatings to combat corrosion and fading.

When you partner with Vicwest, you can be confident you are working with a reputable North American company committed to providing you with quality products and services and supported by experienced Vicwest teams from coast to coast. Our knowledgeable technical and sales staff can assist you with your design, estimating and consulting needs to help you achieve the right solution for your next building project.

Providing solutions for the building envelope is our business, and our metal roofing systems are our crowning glory.



TRADITION 100 AND 150

Creative flexibility for unique design possibilities



Distinctive curved roofs, furnished with the Tradition 100 profile in your choice of material finish make for attractive curved parapets, wall edges or barrel vaulted roofs.

TRADITION 100

Key Advantages

The Tradition 100 panel with the I-style snap-on cap is designed specifically for straight sloped or curved roof applications over a rigid solid surface. It can be wrapped across its width to follow a contoured surface of wall or curved over its length to form a curved parapet wall edge or a barrel vaulted roof. Tradition 100 can be curved along the sheet length to a radii ranging from a minimum of 1500 mm to full straight.

Roof Installation & Preparation

Available in 400 mm widths, the Tradition 100 profile can be installed as a single skin on a solid surface without installation or as an exterior sheet as a fully insulated roof system design (System 3000). Please refer to the System Products Reference Chart on page 14.

The surface to which the Tradition 100 is applied must be a solid, smooth surface, strong enough to provide anchorage for the Snap Clips. The entire roof surface should be covered using a moisture retardant membrane lapped horizontally, starting at the eaves, before Tradition 100 is applied. Please refer to www.vicwest.com for additional information.

Side Lap

The 33 mm (1 9/32") I-style standing seam with snap-on cap is used on the Tradition 100 roof profile.

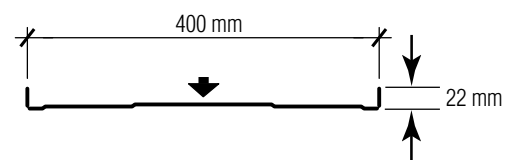
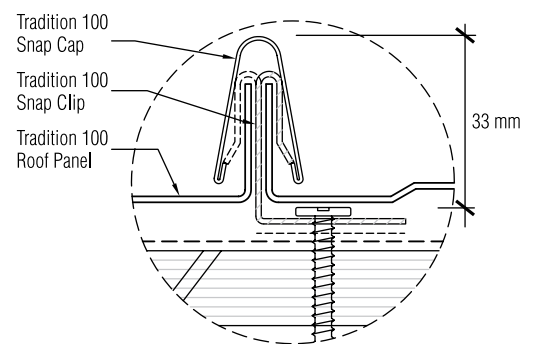

	TRADITION 100	TRADITION 150
Panel Width	400 mm (standard) 15.75"	400 mm (standard) 15.75"
Minimum Length	1.2 m (4'-0")	1.2 m (4'-0")
Maximum Length	12.2 m (40'0")	12.2 m (40'0")
Curve Over Length	✓ **	N/A
Mechanically Seamed	N/A	✓
Requires Solid Substrate	✓	✓
Structural Spanning Capabilities	N/A	N/A
No Exposed Fasteners	✓	✓
Minimum Slope / Degree	3 in 12 14.04 Deg	2 in 12 9.46 Deg
Additional Barrier	1 in 12 4.77 Deg	1 in 12 4.77 Deg
Metallic Finishes	✓	✓

** Field curving with machine supplied by Vicwest

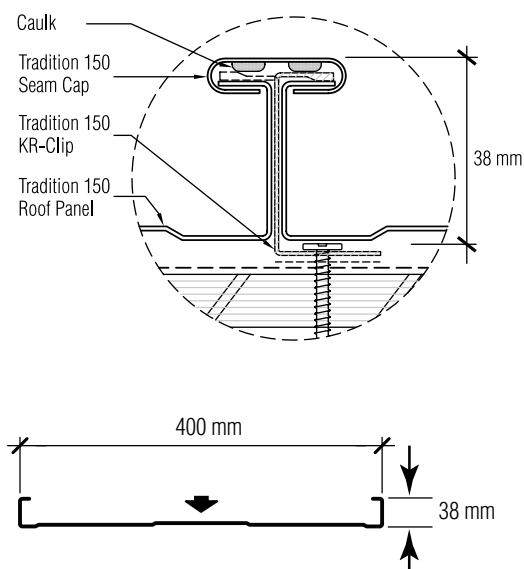

TRADITION 150

Key Advantages

The Tradition 150 panel with the T-style side lap is recommended for straight slope applications. The Tradition 150 is an excellent choice where the roof design possesses slopes as low as 2 in 12 (9.46 deg.) or where snow build-up and water pooling areas are identified.

Roof Installation & Preparation

Available in 400 mm width, the Tradition 150 profile can be installed as a single skin or 3000 system application. Moisture retardant membranes should be considered as a secondary precaution in potential problematic areas. Please refer to vicwest.com for additional information.

Side Lap

The Tradition 150 profile uses the T-style mechanically seamed side-lap which is manufactured with a height of 38 mm (1 1/2").



MARQUIS

Uncompromising style, matched in durability



Achieve the distinct board and batten appearance with the Marquis roof system. This complete system delivers superior insulation values and high efficiency for roofs and wall assemblies.

Key Advantages

The Marquis system possesses superior insulating values as a result of our thermal clip mounting system which reduces thermal bridges. The batten cap provides a structural advantage, results in a more water-tight system, and presents a traditional board and batten appearance.

Thermal clips come in a variety of depths from flush mount to depths which accommodate up to 254 mm of insulating material. Allowance to have 10" of insulation with thermal clip system.

Gypsum board allows for a thermal barrier within the system, thus reducing thermal bridging. No seamer is required and clips are fastened through the gypsum board to the metal deck below with fasteners. The number of screws to be used depends on:

- 1) Magnitude of wind uplift
- 2) Spacing of clips
- 3) Thickness of the inner metal deck.

Roof Installation & Preparation

Marquis is a fully engineered system. It combines a number of roofing elements that must be properly integrated to ensure good performance. To make sure the selected roof and all its components meet the specified performance needs, contact a Vicwest technical representative. All are well-trained in assisting architects and engineers to design with Marquis. Please refer to www.vicwest.com for additional information.

	MARQUIS 450
Panel Width	450 mm (standard) 17.72"
Minimum Length	1.2 m (4'-0")
Maximum Length	12.2 m (40'0")
Curve Over Length	N/A
Mechanically Seamed	N/A
Requires Solid Substrate	✓
Structural Spanning Capabilities	✓ Snap Cap Required
No Exposed Fasteners	✓
Minimum Slope / Degree Without Batten Cap	2 in 12 9.46 Deg
Minimum Slope / Degree With Batten Cap	1 in 12 4.77 Deg

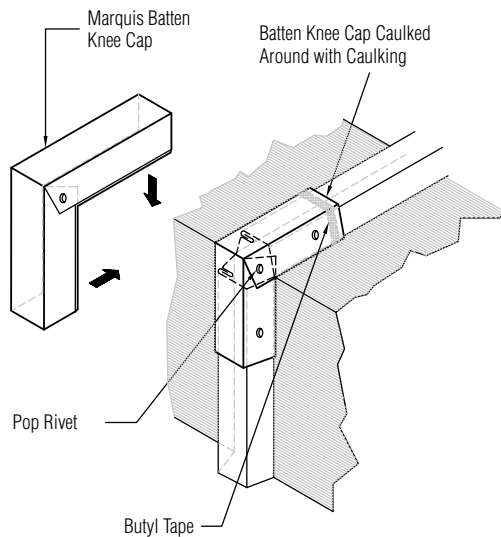
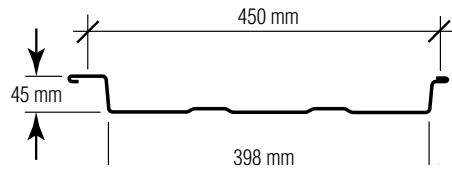
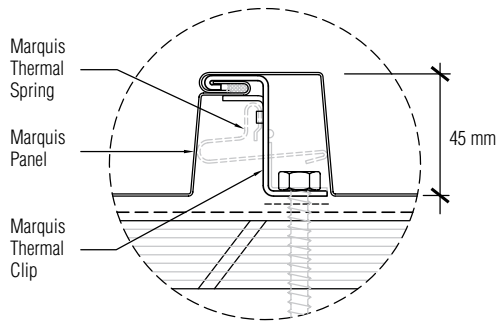

Marquis Batten Cap

The Marquis batten cap provides a distinctive architectural feature by creating bolder shadow lines. With single skin applications, the batten cap provides increased rigidity. It is also used to provide perfect transitions from roof to fascia.

Transitions

With the batten cap, Marquis provides a perfect transition from roof to fascia, and even from fascia to soffit.

Batten Cap Depth

50mm (1.968").



PRESTIGE

Impressive for Residential or Commercial Roofs



Accomplish a sophisticated batten style appearance with Prestige. With a name derived from the prestigious style only it can accomplish, Prestige reflects a true artisan quality. A true display of steel roofing made beautiful.

Key Advantages

This classic standing seam profile, mimicking a batten style roofing panel, will enrich the appearance and add value to any commercial or residential roofing project. Prestige is a snap-in/interlocking progressive system. Hidden fasteners mean there is no penetration of the metal, thus preventing water from infiltrating the system. Note that the slotted anchoring location allows for thermal expansion of the panel.

Roof Installation & Preparation

It is recommended that Prestige be installed only on single skin applications where a solid base of plywood, steel deck or concrete is available. Ensure the decking area is covered with a good quality air barrier. Prestige uses a hidden fastening and is installed using a snap- in-place design and does not require seamers. Prestige is a cost effective solution that offers trouble free installation. Please refer to www.vicwest.com for additional information.

	PRESTIGE
Panel Width	305 mm / 400 mm / 508 mm (12")* / (15.75") / (20")
Minimum Length	1.2 m (4'-0")
Maximum Length	9.2 m (30'0")
Curve Over Length	N/A
Mechanically Seamed	N/A
Requires Solid Substrate	✓
Structural Spanning Capabilities	N/A
No Exposed Fasteners	✓
Minimum Slope / Degree Without Batten Cap	3 in 12 14.04 Deg

* Prestige 12" manufactured in Delta, BC only

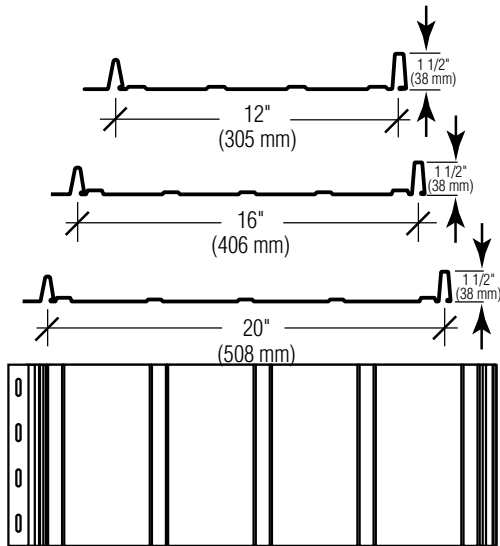



Surprisingly economical and highly functional



This low slope roofing system produces a remarkably attractive roof with its corrugated panel appearance. Completely weather proof and suited for projects in high wind uplift zones, TSR stays secure with incomparable quality, long life, and three separate systems to provide energy efficiency.

Key Advantages

The TSR system demonstrates all weather performance in areas of extreme winds, rains and heavy snow. It is engineered specifically for extremely low slope roof applications common to industrial and institutional buildings.

Roof Installation & Preparation

TSR is one of our most versatile profiles. It can be installed on single skin, or on the 1000, 2000, 3000 systems, allowing for varying degrees of efficiency. TSR is an excellent solution for achieving weather tightness on extremely low slope roofs where pooling can be problematic. Please refer to www.vicwest.com for additional information.

Testings

TSR has UL class 1-90 and ASTM 1592 ratings on both 22 gauge and 24 gauge for purlin spacing of 5 feet (1500 mm). And now the TSR system is one of the few steel roof systems to have been tested under and passed UL 1897, a stringent wind uplift test standard for roof coverings. Vicwest's new rating of 140 pounds per square foot uplift (6.7 kPa) with no visible damage will give owners great confidence in the integrity of their roof system.

	TSR
Panel Width	610 mm (24")
Minimum Length	1.2 m (4'-0")
Maximum Length	12.2 m (40'0")
Curve Over Length	N/A
Mechanically Seamed	✓
Requires Solid Substrate	N/A
Structural Spanning Capabilities	✓
No Exposed Fasteners	✓
Minimum Slope / Degree	1/4 in 12 1.19 Deg

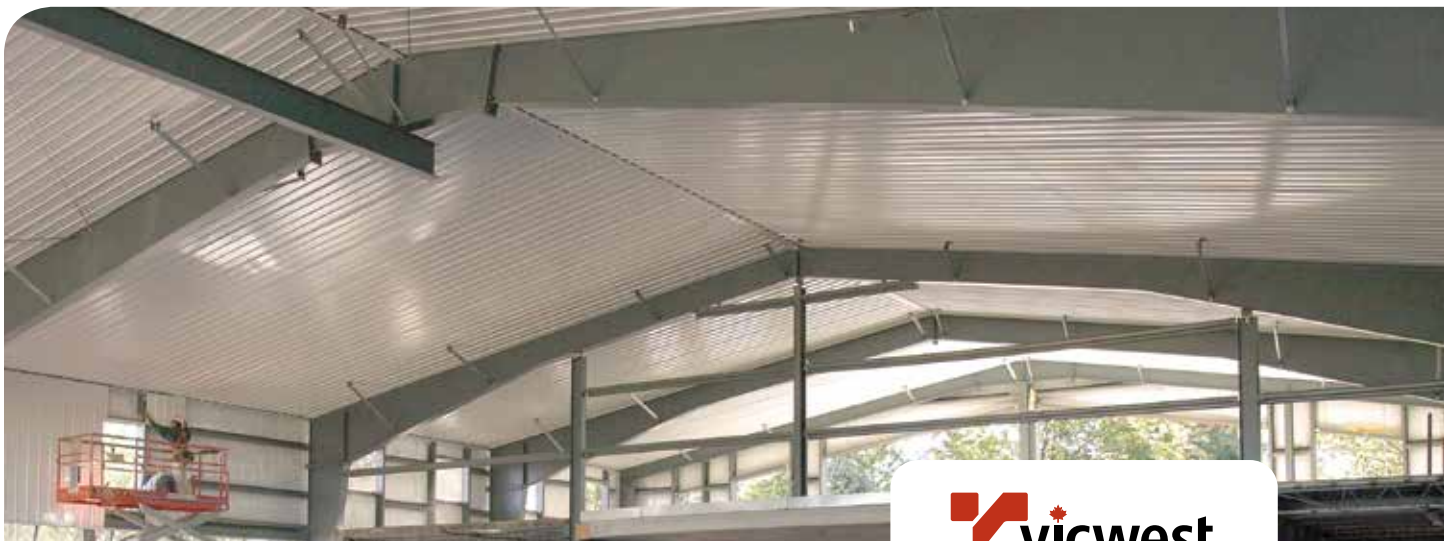
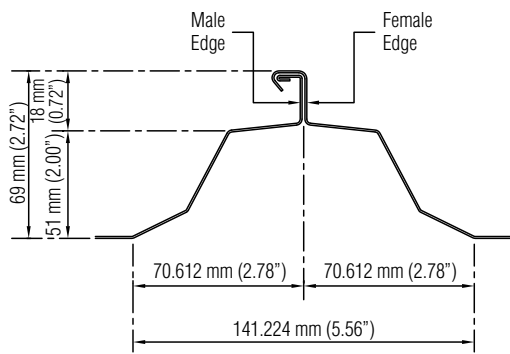
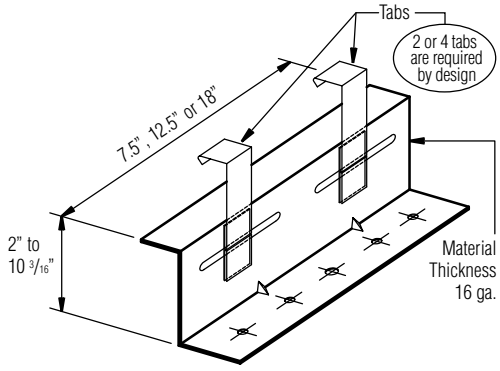

EXPOSED FASTENER

Colour-matched fasteners give this profile a sleek look

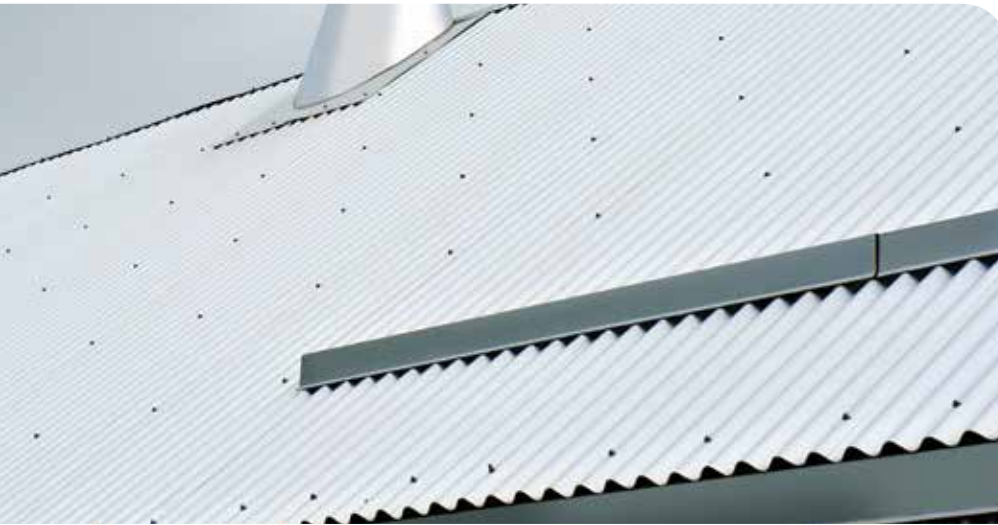

Installing Vicwest profiles using exposed fasteners makes for a quick installation, therefore becoming a much more cost effective alternative to a concealed fastening approach.

Key Advantages

Exposed Fastening System is an economical choice for roof designs on a firm budget.

Roof Installation & Preparation

Installing Vicwest profiles using exposed fasteners makes for a quick installation therefore becoming a much more cost effective alternative to a concealed fastening approach. Using the exposed fastening system may also be a favourable choice if it is suspected that the building may experience future additions or expansions in which case an exposed fastening system will allow the panel to be easily removed and replaced to accommodate accordingly. Please refer to www.vicwest.com for additional information.

Please contact one of our experts to recommend the fastener best suited for your particular application.



MacKay-Lyons Sweetapple Architects, Photo by Greg Richardson

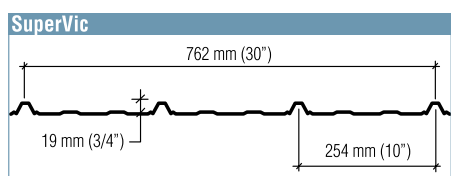
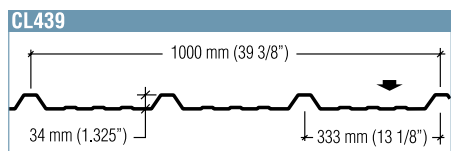
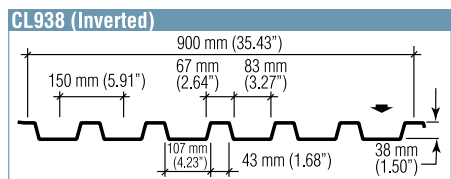
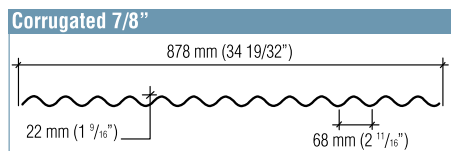
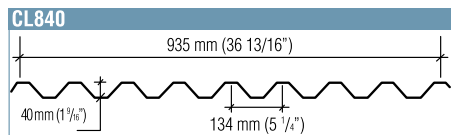
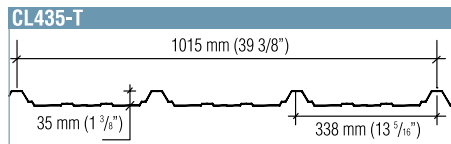
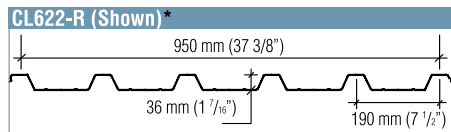
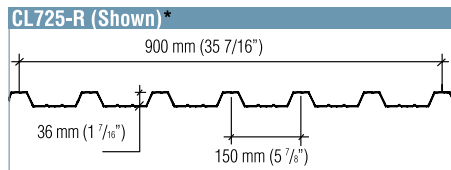
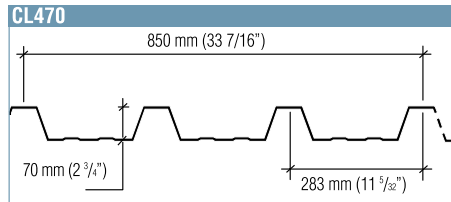
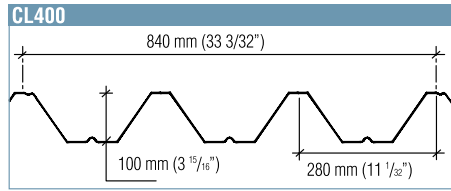

	EXPOSED FASTENER
Panel Width	Varies
Minimum Length	1.2 m (4'-0")
Maximum Length	12.2 m (40'-0")
Curve Over Length	N/A
Mechanically Seamed	N/A
Requires Solid Substrate	N/A
Structural Spanning Capabilities	✓
No Exposed Fasteners	N/A
Minimum Slope / Degree	3 in 12 14.04 Deg

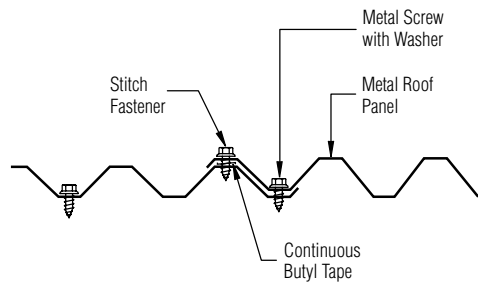

CL400



CL470



CL725-R



CL622-R



CL435-T



CL840



CORRUGATED 7/8"



CL938



CL439



SuperVic



TECHNICAL

Roofing Systems

Single Skin on Rigid Decking

Vicwest Roof profiles are ideal in applications where a solid deck is available for support. Our roof profiles are adaptable to any solid base material such as plywood, steel deck or concrete. To prevent internal air leakage, which can cause condensation problems, Vicwest recommends the use of a good air barrier over the structural material.

System 1000

For light industrial applications, choose the Vicwest System 1000 as an economical and attractive roof. Vicwest roof products can be used as a single skin or with or without metal building insulation as required.

System 2000

The Vicwest System 2000 roof provides an upgraded system with an L-800 Liner sheet air vapour barrier and a wider range of insulation values from which to choose.

System 3000

The Vicwest System 3000 roof is designed for almost all roofing applications. It combines all the elements needed for a high performance weather tight roof. It integrates all necessary roofing components and provides a single source of responsibility for the roof design and construction. For a more economical approach, where the interior humidity of the building is less than 35%, the thermal barrier may be eliminated and deck fillers installed to support the side and end laps of the air vapour barrier. Caution must be exercised to ensure that humidity conditions during construction also remain below this level.

Images reflect the Marquis profile.
Actual components will vary depending on roof profile selected.

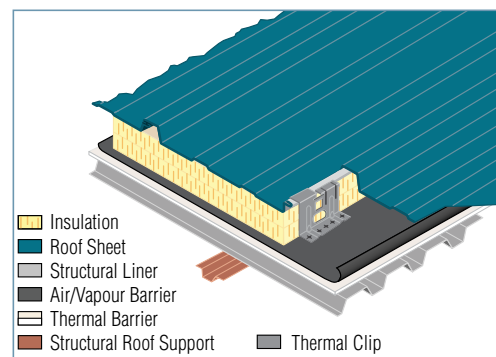
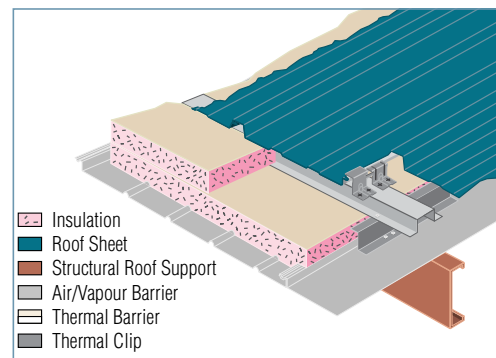
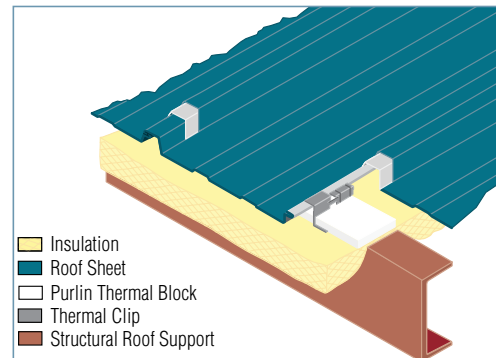
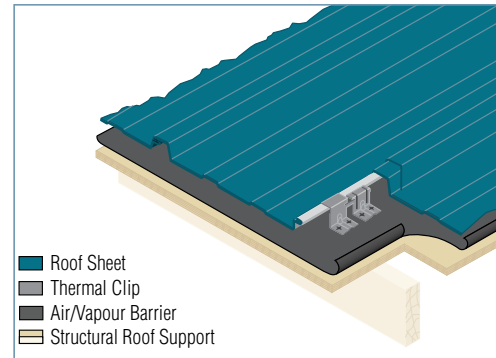

Roof Systems & Corresponding Components

Major Components	ROOF SYSTEM			
	Single Skin	1000	2000	3000
Exterior Panel	✓	✓	✓	✓
Panel Clip	✓	✓	✓	✓
Metal Building Insulation		✓		
Semi Rigid Insulation			✓	
Rigid Insulation				✓
Subgirt Clip System			✓	
L-800 Liner			✓	
Asphaltic Air/Vapour Barrier	✓			✓
Gypsum Board				✓
Structural Roof Deck				✓
SYSTEM PRODUCT	SINGLE SKIN	1000	2000	3000
Tradition 100	✓			✓*
Tradition 150	✓			✓
Marquis	✓	✓	✓	✓
Prestige	✓			
TSR	✓	✓	✓	✓
Exposed Fastener	✓	✓	✓	✓*

* Special precautions must be taken, please contact a Vicwest representative

Accessories & Material Finishes

Material Finishes

Z275 Galvanized or AZM150 Aluminum-Zinc Alloy coatings are recommended for general installations.

WeatherXL® is Vicwest's Silicone Modified Polyester (SMP) coating. With its unique resin system, this SMP topcoat combines a mix of ceramic and inorganic pigments. Selected WeatherXL® colors possess reflectance values that are Energy Star® qualified, meet current cool roof standards and help towards earning LEED™ certification. In addition to outstanding colour performance, WeatherXL® is resistant to stains, abrasions and metal marking which allows it to endure the physical stresses of fabrication, transit and construction while minimizing cracking and marring. Vicwest is confident in the WeatherXL® system and is offering customers an extensive colour palette with exceptional film integrity and color protection. WeatherXL® is supported by a 40-year limited warranty. Please refer to our colour chart for the tint that best matches your design and our compatibility chart for available gauges.

Vicwest's **Expressence** finishes, utilizing the durable PVDF coating system in matte, satin or textured finishes, replicate natural materials like wood, stone and metal. Covered by a 40-year paint performance warranty, PDVF coating is based on Kynar® and Hylar® resins to provide maximum protection and optimal colour retention. Please refer to our Expressence Colour Card for a pattern finish that best achieves the desired effect.

Closures

Types: 1. Metal closures to match finish of metal cladding. 2. Foam closures.





Availability: Both metal and foam closures are available for installation over and under panel for most Vicwest profiles.

Application: Metal closures are used to fill the voids of the exterior panel at peak and eave of roof. These closures allow air circulation within the panel between the exterior sheet and insulation to control condensation.

Foam closures are used to seal in weathertight and/or airtight installations.

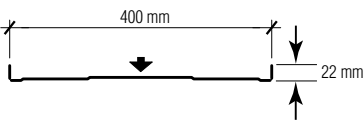
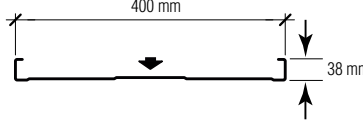
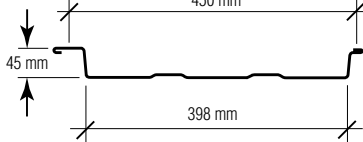
N.B: For availability and colour selection of all these products, please contact Vicwest or visit vicwest.com.

System Products Reference Chart

	TRADITION 100	TRADITION 150	MARQUIS 450
			
			
Panel Width	400mm (15.75")	400mm (15.75")	450 mm (17.72")
Minimum Length	1.2 m (4'-0")	1.2 m (4'-0")	1.2 m (4'-0")
Maximum Length	12.2 m (40'-0")	12.2 m (40'-0")	12.2 m (40'-0")
Curve Over Length	✓**		
Mechanically Seamed		✓	
Requires Solid Substrate	✓	✓	✓
Structural Spanning Capabilities			✓ Batten Cap Required
No Exposed Fasteners	✓	✓	✓
Minimum Slope / Degree	3 in 12 / 14.04° 1 in 12 / 4.77° (Membrane Required)	2 in 12 / 9.46° 1 in 12 / 4.77° (Membrane Required)	2 in 12 / 9.46° 1 in 12 / 4.77° (Batten Cap)

* Prestige 12" manufactured in Delta, BC only

** field curing required with machine supplied by Vicwest

Note: For slopes below 2:12 please contact your local Vicwest representative for specific recommendations

	PRESTIGE	TSR	SUPERVIC EXPOSED FASTENER
	508 mm / 400 mm / 305 mm (20") / (15.75") / (12")*	610 mm (24")	Varies
	1.2 m (4'-0")	1.2 m (4'-0")	Varies
	9.15 m (30'-0")	12.2 m (40'-0")	Varies
			Call for Details
	✓	✓	
		✓	✓
	✓	✓	
	3 in 12 / 14.04°	1/4 in 12 / 1.19°	3 in 12 / 14.04°

ENERGY SAVINGS & LEED™



Vicwest is committed to revitalizing Canada's forests and wildlife by contributing to Canadian environmental groups through various eco-gifts and sponsorships.

Metal Cladding, Decking and Roofing by Vicwest provides design professionals with the ability to design a building with environmental sustainability in mind. By incorporating Vicwest metal building components into your design, the environment of your build will continue to function properly and meet the needs of those who occupy it without endangering the health and welfare of future generations.

- Vicwest offers a variety of WeatherXL® finishes which are Energy Star® qualified. Ask your representative for details.
- When permitted by local building codes, re-roofing applications can require little removal of waste from building sites resulting less in landfills.
- Vicwest Metal Roofing and Cladding Systems are manufactured with recycled content. They are extremely durable, have a long-life cycle and are 100% recyclable at the end of their life.
- Metal Roofing Systems by Vicwest can reduce cooling consumption during summer months. This results in less fossil fuels burning in the atmosphere, reducing smog and pollution.
- Vicwest's manufacturing facilities recycle cardboard, paper, wood and steel. We're always looking for ways to reduce energy consumption.
- Vicwest metal roofing profiles can help designers earn LEED™ certification. Please visit our website at www.vicwest.com for recent case studies showcasing these certified buildings.
- When installed on site, Vicwest Metal Roofing and Cladding Systems will not release VOC's (Volatile organic compounds) into the atmosphere. This applies to interior installations.

For further information on how steel can meet LEED® Canada requirements as outlined by the Canada Green Building Council, please visit our website for our ecoScorecard™. The ecoScorecard™ evaluates and documents the environmental benefits of our products making it easy for you to compile and print submission documents for LEED® and other green building programs.



OTHER VICWEST PRODUCTS

Vicwest has what you need to succeed

For over 100 years, Vicwest has been a leading manufacturer of premium quality metal cladding, roofing and decking in Canada, redefining and setting the standards in metal building construction and design.

Visit vicwest.com for our complete line of metal building products.

- Wall Systems
- Roof Decks
- Floor Decks
- Roof Systems
- Steel Trims & Accessories
- Insulated Metal Panels
- Architectural Panels



See more projects at www.vicwest.com

Up-to-date Information, Best Practices, everything needed to work with Vicwest Steel Roof Systems in the most efficient manner, from the product line to specialty coatings, special projects and accessories. It's all here for a complete roofing system.

The Vicwest Commitment

For more than 85 years, we've understood that people choose Vicwest not only because we build superior products, but because we stand behind them. Every Vicwest product we sell is backed by leading system warranties, comprehensive service, and ultimate reliability. At Vicwest, we're committed to continually improving upon and developing new building products to protect the places where we live, work and play. At Vicwest, we're building for tomorrow.

Note: For more information about building with steel, please refer to the CSSBI publication on the structural integrity of steel building panels.

In accordance with ongoing efforts to improve our products and their performance, Vicwest Building Products reserve the right to change without notice the specifications contained herein.

The contents herein are for general information and illustrative purposes only and are not intended to serve as any type of advice. Every effort is made to ensure the accuracy of the information included in this brochure and it is believed that the information contained herein is accurate and reliable as of the date of publication. Vicwest Building Products does not warrant or represent the accuracy or reliability of any information included in this brochure. Any reliance on any information without consultation with Vicwest Building Products or a duly authorized representative shall be at the user's own risk.



Vicwest Locations:
Edmonton, Alberta
Saskatoon, Saskatchewan
Stratford, Ontario
Oakville, Ontario
Victoriaville, Quebec
Memramcook, New Brunswick
Kensington, PEI

