

2013 Design Guide for Single Ply Roofing

To ensure that clients obtain high quality polymer-based single ply roofing, through a partnership of quality assured manufacturers & contractors.

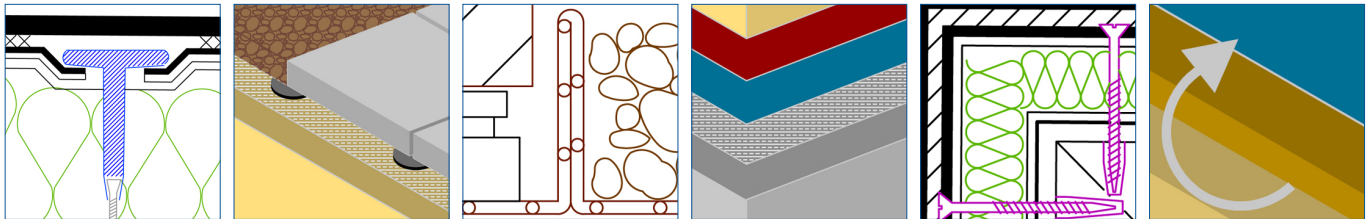

SPRA

We've Got It Covered

Single Ply Roofing Association

www.spra.co.uk

CONTENTS

1. Contents			
1. OBJECTIVES AND SCOPE	3		
1.1. OBJECTIVES	3		
1.2. SCOPE	3		
2. THE CLIENT BRIEF - SETTING PERFORMANCE TARGETS AND CONSTRAINTS	3		
2.1. INTRODUCTION	3		
2.2. SUSTAINABILITY	4		
2.2.1. Environmental impact	4		
2.2.2. Durability	4		
2.2.3. Renewables	4		
2.2.4. Rainwater harvesting	4		
2.3. THERMAL PERFORMANCE	4		
2.3.1. Building Regulations	4		
2.3.2. Control of condensation	5		
2.3.3. Control of air leakage	5		
2.3.4. Resistance to solar radiation	5		
2.4. ACOUSTIC PERFORMANCE	5		
2.5. LOADS	6		
2.5.1. Wind load	6		
2.5.2. Roof traffic	6		
2.5.3. Plant and equipment	6		
2.6. FIRE PERFORMANCE	6		
2.6.1. Building Regulations	6		
2.6.2. External Fire Source (AD B)	6		
2.6.3. Fire Resistance (AD B)	6		
2.6.4. Insurers Requirements	6		
2.7. TRANSMISSION OF DAYLIGHT	6		
2.8. LIGHTNING PROTECTION	7		
2.9. APPEARANCE	7		
2.10. SECURITY	7		
2.11. SUPPLEMENTARY USES	7		
2.12. MAINTENANCE FREQUENCY AND COST	7		
2.13. WARRANTY	7		
2.14. SAFETY DURING CONSTRUCTION AND USE	7		
3. DESIGN	8		
3.1. INTRODUCTION	8		
3.2. TYPES OF ROOF SYSTEM	8		
3.2.1. Components	8		
3.2.2. The warm roof	9		
3.2.3. The inverted warm roof	10		
3.2.4. Roof gardens or 'green/living roofs'	11		
3.2.5. The cold roof	12		
3.3. FALLS	13		
3.4. DRAINAGE	13		
3.5. SUSTAINABILITY	13		
3.5.1. Environmental Impact	13		
3.5.2. Durability	14		
3.5.3. Renewables	14		
3.5.4. Design to reduce waste	14		
3.6. THERMAL INSULATION	14		
3.6.1. Building Regulations	14		
3.6.2. Control of condensation	15		
3.6.3. Control of air leakage	16		
3.6.4. Resistance to solar radiation	17		
3.6.5. Selection criteria	17		
3.7. ACOUSTIC DESIGN	17		
3.8. RESISTANCE TO LOADING	18		
3.8.1. Live loading - Wind	18		
3.8.2. Live loading - Access, foot traffic and construction process	18		
3.8.3. Dead loading - Plant and equipment	18		
3.9. FIRE PERFORMANCE	19		
3.9.1. Building Regulations	19		
3.9.2. Insurers requirements	19		
3.10. ROOFLIGHTS	19		
3.11. LIGHTNING PROTECTION	19		
3.12. APPEARANCE	19		
3.13. SECURITY	19		
3.14. COMPATIBILITY OF COMPONENTS	20		
3.15. METHODS OF ATTACHMENT	20		
3.15.1. Introduction	20		
3.15.2. Mechanically fixed	20		
3.15.3. Adhered	22		
3.15.4. Ballasted	23		
3.16. DETAILING	23		
3.16.1. General principles	23		
3.16.2. Specific types	24		
3.17. SAFETY DURING CONSTRUCTION AND USE	26		
4. MATERIALS	26		
4.1. STRUCTURAL DECK	26		
4.1.1. Introduction	26		
4.1.2. Profiled metal sheet	26		
4.1.3. Timber/Panels	26		
4.1.4. Concrete	27		
4.1.5. Composite metal decks	27		
4.1.6. Structural insulated panel systems	27		
4.2. VAPOUR CONTROL LAYER	28		
4.3. THERMAL INSULATION	28		
4.3.1. Classification	28		
4.3.2. Cellular materials	28		
4.3.3. Fibrous materials	30		
4.3.4. Composite Insulation	30		
4.3.5. Other insulation types	30		
4.4. WATERPROOF MEMBRANES	30		
4.4.1. Introduction	30		
4.4.2. Product certification	30		
4.4.3. Product standards	30		
4.4.4. Generic types of membrane	30		
4.4.5. Selection criteria for single ply membrane	31		
4.5. ANCILLARY COMPONENTS	31		
4.5.1. Introduction	31		
4.5.2. Mechanical fasteners	31		
4.5.3. Adhesives	32		
4.5.4. Pre-formed details	32		
4.5.5. Membrane-lined gutters	32		
4.5.6. Rainwater outlets	32		
4.5.7. Fall-arrest anchorages	32		
4.5.8. Lightning conductor pads	33		
4.5.9. Rooflights	33		
4.5.10. Decorative profiles	33		
4.5.11. Paving support pads	33		
4.5.12. Ballast	33		
5. WORKMANSHIP	33		
5.1. CERTIFICATION OF TRAINING PROGRAMME, SEQUENCING AND INTERRUPTIONS	33		
5.2. STORAGE AND HANDLING OF MATERIALS	34		
5.3. HEALTH AND SAFETY REGULATIONS	34		
5.4. EXISTING SUBSTRATE	34		
5.5. DECK	34		
5.6. VAPOUR CONTROL LAYER	35		
5.7. THERMAL INSULATION	35		
5.7.1. Mechanically fastened	35		
5.7.2. Adhesion	35		
5.8. WATERPROOF MEMBRANE	36		
5.8.1. Mechanical fastening	36		
5.8.2. Adhesion	36		
5.8.3. Ballast	37		
5.9. TEMPORARY PROTECTION OF ROOF SYSTEM	38		
5.10. INSPECTION	38		
5.11. TESTING FOR INTEGRITY	38		
6. MAINTENANCE	39		
7. ROOF REFURBISHMENT	39		
7.1. INTRODUCTION	39		
7.2. REMOVAL OR OVERLAY OF EXISTING SYSTEM	39		
7.3. CHANGE OF USE	39		
7.4. EXISTING DECK	39		
7.5. INSULATION	40		
8. REFERENCES	40		
8.1. REGULATIONS	40		
8.2. NORMATIVE REFERENCES	40		
8.3. INFORMATIVE REFERENCES	41		
8.4. OTHER REFERENCES	41		

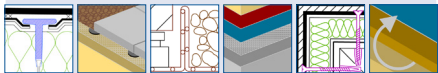

This design guide has been prepared by the Technical Committee of the Single Ply Roofing Association (SPRA) which comprises representation from all membership categories (Membrane manufacturer, Associate manufacturer and Contractor).

Based on extensive research and over thirty-five years' experience in the UK, it is the current industry view of best practice in the design, selection of materials, installation and maintenance of single ply roofing systems and includes reference to all relevant European and British Standards as appropriate. Since Regulations and European and British Standards are under continuous review, the reader should confirm their status with the appropriate institutions before referring to them in specifications.

A national or European certificate issued by a European Technical Approvals issuing body is one method to satisfy The Building Regulations in respect of the fitness for purpose of a single ply roofing membrane (so long as the conditions of use are in accordance with the terms of the certificate). This can also be demonstrated by a manufacturer's declaration of conformity with the new harmonised European Standard BS EN 13956.

In addition, certain projects may be subject to higher requirements specified by insurance companies for the purposes of property protection (e.g. material approvals to Loss Prevention Certification Board (LPCB) or full roof system approvals issued by FM Approvals (an affiliate of FM Global).

Design Guide

for Single Ply Roofing

1. OBJECTIVES AND SCOPE

1.1. OBJECTIVES

This Guide is intended to:

- Set a standard for the single ply roofing industry.
- Encourage the client to set performance criteria against which the design can be assessed and reviewed.
- Assist the decision-making process in the design of a roof system based upon polymeric single ply water-proofing membranes.
- Provide the designer with technical information which, together with manufacturers' advice and published Regulations and Standards will be sufficient for the design of a single ply roof.

1.2. SCOPE

The recommendations given in this Guide are applicable to all roof forms in new construction and refurbishment, non-dwellings and dwellings. They do not cover all aspects of single ply roofing but feature those design aspects believed to be important for optimum performance.

Section 5 'Workmanship' is intended to inform the designer of those aspects which will be of relevance to the design and supervision functions; it is not an installation manual for the contractor.

In all instances it has been assumed in drafting this Guide that construction will be carried out by operatives who have passed the relevant SPRA manufacturers' certified training course, under the direction of qualified supervisors as required by the SPRA Criteria for Membership.

This document takes the form of guidance and recommendations. It should not be quoted as if it is a specification and particular care should be taken to ensure that claims of compliance are not misleading. SPRA publishes a generic specification for single ply roofing which can be used to set criteria for performance, product support and training in accordance with the SPRA Criteria for Membership and Code of Conduct.

Compliance with this Guide does not in itself confer immunity from legal obligations.

2. THE CLIENT BRIEF - SETTING PERFORMANCE TARGETS AND CONSTRAINTS

2.1. INTRODUCTION

This section lists those aspects of performance together with any constraints, which should be considered in the client's brief to the designer.

At the earliest possible stage and with the early involvement of the membrane manufacturer, these targets and constraints should be identified by the client and designer, together with the priority of each. This will enable effective review and modification as the design develops.

Fundamentally, a single ply roof system must provide protection from all weather conditions likely to be experienced during its design life. Such protection may be required before building completion to facilitate rapid fit-out of the interior. The roof system must also perform satisfactorily against a wide range of other targets and constraints as required by legislation, by the client, by the building insurer, and by the design of the substructure and services.

Since the priority order of performance is unique to each design, the following performance criteria are not ranked in order of importance.

2.2. SUSTAINABILITY (for Design see section 3.5)

2.2.1. Environmental impact

Environmental impact ranges from consumption of natural resources and energy during manufacture and installation to removal, recycling, reuse and disposal. Realistic durability and maintenance input estimates are an essential pre-requisite of impact studies.

Thermal insulation performance also has a major positive effect on the environmental impact of any roofing proposal.

The environmental impact of a particular design is specific to that design. Many simplistic impact ratings for individual materials are available, but in reality, the impact of a design is dependent upon the complete system and the client's selection of which environmental issues are most important.

Therefore, it is recommended that the client's priorities for environmental assessment are established at an early stage.

Single ply roofing is fully represented in the various levels of environmental assessment now recognised by UK construction:

- *Individual product assessments:* SPRA members can provide information on individual product environmental profiles of the materials they supply, including the provision of recycled products.
- *Generic assessments for component types:* SPRA assisted the BRE with providing information on single ply membranes for production of the BRE Green Guide to Specification 2008.
- *Generic assessments for total roof systems* (BRE Green Guide to Specification): ratings for typical single ply systems can be found at www.bre.co.uk/greenguide
- *Generic assessments for whole-buildings* (BRE BREEAM ratings and Code for Sustainable Homes): further information available at www.breeam.org and www.planningportal.gov.uk

BREEAM is the BRE's Environmental Assessment Method for the performance of entire buildings. Credits are awarded according to the performance of the building using the following factors - Management, Health & Wellbeing, Energy, Transport, Water, Materials, Land use/Ecology & Pollution. These credits are then added together to produce one of the five overall ratings: Outstanding, Excellent, Very Good, Good or Pass.

2.2.2. Durability

Durability is derived from artificial ageing and long-term experience in the construction. It usually refers to individual components. It should not be confused with the term of any warranty (see 2.13). Service life is generally applied to systems of components and assumes that normal maintenance procedures have been followed. In financial terms, service life is the period over which the depreciated initial capital cost and annual maintenance cost does not exceed the annualised cost of a replacement roof system.

The British Board of Agrément (BBA) assesses the durability of single ply roofing membranes as part of the Agrément Certification process. The durability of single ply membranes supplied by members of SPRA is typically in excess of 30 years and Membrane manufacturers must hold current British Board of Agrément Certificates. Check these at www.bbacerts.co.uk

2.2.3. Renewables

Single ply roof systems are fully compatible with roof-level renewable technologies such as photovoltaic (PV) solar water heating (RH) and wind turbines. Some single ply membranes can be used to improve the efficiency of photovoltaic systems as compared with other roof coverings. Subject to certification, single ply roofing systems are also fully compatible with a range of green roof finishes.

2.2.4. Rainwater harvesting

Single ply roof systems are fully compatible with systems for the storage of rainwater, either at roof, ground or basement level. Both gravity and siphonic drainage systems can be used for collection.

2.3. THERMAL PERFORMANCE

(for Design see section 3.6)

2.3.1. Building Regulations

England & Wales – Building Regulations Part L 2010, Conservation of fuel and power

Note: Part L 2013 is expected to be implemented in April 2014

New Build

Part L1A (new dwellings) and Part L2A (new buildings other than dwellings) (extracts):

New buildings - Regulation 17C

'Where a building is erected, it shall not exceed the target CO₂ emission rate for the building that has been approved;..'

Energy performance certificates - Regulation 17E

'The person carrying out the work shall –

- Give an energy performance certificate for the building to the owner of the building; and*
- Provide the Local Authority with the reference number for the certificate.'*

Schedule 1 – Part L Conservation of fuel and power

'L1. Reasonable provision shall be made for the conservation of fuel and power in buildings by:

- a) limiting heat gains and losses -
 - (i) through thermal elements and other parts of the building fabric;...'**

Refurbishment

Part L2B (existing dwellings) & Part L2B (existing buildings other than dwellings) (extracts):

Requirements relating to thermal elements - Regulation 4A

- (1) 'Where a person intends to renovate a thermal element, such work shall be carried out as is necessary to ensure that the whole thermal element complies with the requirements of paragraph L1(a)(i) Schedule 1' (See above).*
- (2) 'Where a new thermal element is replaced, the new thermal element shall comply with the requirements of L1(a)(i) of Schedule 1' (See above).*

Scotland - Scottish Building Standards Agency (SBSA) Technical Handbooks – Section 6 Energy (extracts):

Standard 6.1 - 'Every building must be designed and constructed in such a way that:

- (a) the energy performance is estimated in accordance with a methodology of calculation approved under regulation 7(a) of the Energy Performance of Buildings (Scotland) Regulations 2008; and*
- (b) the energy performance of the building is capable of reducing carbon dioxide emissions.'*

Standard 6.2 - 'Every building must be designed and constructed in such a way that an insulation envelope is provided which reduces heat loss.'

2.3.2. Control of condensation

Satisfactory performance in respect of the control of condensation both on the surface of and within the roof system is essential if thermal and durability targets are to be realised. All designs should be checked in terms of condensation risk for the intended building function (and any future change of use).

The Building Regulations Approved Documents C (AD C) sets mandatory requirements in respect of the control of condensation, which should be designed and constructed in accordance with BS 5250 and BS EN ISO 13788.

The requirement for ventilation of cold roofs is also covered within BS 5250.

2.3.3. Control of air leakage (for Design see section 3.6.3)

Approved Document L of the Building Regulations states the relevant requirements for air tightness in buildings. The roof and those elements which penetrate it should be suitably airtight and must comply when tested with the minimum requirements as defined in the Approved Document.

2.3.4. Resistance to solar radiation

Resistance to solar radiation concerns issues of durability and of heat absorption and radiation. Infrared solar radiation has the potential to increase significantly summer cooling loads, even on well-insulated roofs. Its ultra-violet component is a major determinant in the ageing of construction materials.

Heat absorption is a function of colour and texture. Dark membranes not only absorb more solar radiation and transmit it to the rest of the roof system; they also radiate heat at night at a greater rate thereby cooling the roof surface. Heat absorption has become more important in roof design. It may affect the performance of energy capture equipment, but it is not currently included in the SAP and SBEM calculation methods for AD L1 and AD L2 respectively.

2.4. ACOUSTIC PERFORMANCE (for Design see section 3.7)

SGD7/10 - Acoustic control within buildings

All likely sources of external and internal noise should be identified in order to establish the degree of attenuation required to suit the building function. Because acoustic performance is heavily dependent upon the selection of materials (especially any ceilings, the deck and the thermal insulation) early identification of the requirement may assist the design selection process.

Impact noise from rain must be considered at an early part in the roof design, due to the fact that this can significantly increase the indoor noise level.

Building Bulletin 93 (BB93) outlines the methods of compliance for Educational facilities. Health Technical Memorandum 08-01 (HTM 08-01) sets out the methods for compliance for Healthcare facilities. Both of these guidance documents include a requirement to minimise the noise of rainfall on lightweight roofs and whilst no limit is set, methods of control must be included and justified to Building Control.

The inherent flexibility of single ply membranes combined with appropriate insulation and fastening systems can offer a significantly improved acoustic performance when compared with rigid metal composite roofing systems.

Advice with regards to individual constructions is available from SPRA insulation manufacturer members (see 3.7).

2.5. LOADS (for Design see section 3.8)

2.5.1. Wind load

Wind load is established by calculation in which site topography and location are major determinants but its level is also influenced by the building design as a whole. It is therefore advisable to estimate wind load at an early stage. Detailed calculation can then follow when the design is more developed (see 3.8.1).

2.5.2. Roof traffic (for Design see section 3.8.2)

Consideration should be given to the suitability for roof traffic both during and after construction. Areas that will sustain heavy foot traffic after installation but prior to completion should be adequately protected.

Suitable provision should be made for maintenance access to plant and any other areas requiring regular access. SPRA manufacturers offer guidance in the treatment of such areas including, in some cases, materials for walkways and load spreading. Extra provision should be considered where additional plant is expected in the future (e.g. as units are let).

Where single ply roofing systems are incorporated in balconies and podia accessible to the disabled, the construction must comply with the requirements of the Building Regulations Approved Document M.

2.5.3. Plant and equipment (for Design see section 3.8.3)

[SGD9/11 Wind load design requirements](#)

Flat roofs are ideal locations for plant and equipment. At the earliest possible stage, the type, location, support and frequency of access to plant and weathering of services' access points should be agreed. This will inform later decisions on roof system type and selection of components. It is recognised that late changes are often necessary to plant both in terms of location and type. If this is likely, selection of a suitable support arrangement will help to reduce risk of damage to the roof covering or delays to programme.

2.6. FIRE PERFORMANCE (for Design see section 3.9)

2.6.1. Building Regulations

Approved Document B (AD B) 'Fire Safety' to the Building Regulations 2010 (England & Wales), contains minimum guidance for demonstrating the fire performance of roofs when the fire source is either external or internal to the roof construction. AD B is in two volumes: Volume 1 "Dwelling houses" (e.g. residential construction) and Volume 2 "Buildings other than Dwelling houses" (e.g. commercial construction).

2.6.2. External Fire Source (AD B)

Performance in terms of the resistance of single ply roofs to external fire exposure is determined by reference to either the national test BS 476-3 or European test method 't4' specified in ENV 1187:2002.

The European 't4' method is effectively the BS 476-3 method minus the requirement to test for flame spread.

All roof coverings require either a national classification (e.g. 'AA', 'AB', 'AC') in accordance with BS 476-3 etc or a European classification (e.g. 'BROOF t4', 'CROOF t4', etc) in accordance with BS EN 13501-5.

For 'dwelling houses' Table 5 in Section 10 of AD B Volume 1 defines limitations of use on roof coverings based on national or European classification.

For 'buildings other than dwelling houses' Table 16 in Section 14 of AD B Volume 2 defines limitations of use on roof coverings based on national or European classification.

2.6.3. Fire Resistance (AD B)

In some circumstances the roof, or part of the roof, may also need to demonstrate a minimum period of fire resistance when tested to either national or European standards (for example if used as an escape route or if the roof performs the function of a floor in terms of the buildings overall stability). In these situations, the guidance of Table A1 to Appendix A of AD B should be followed to determine the minimum fire resistance period required.

2.6.4. Insurers Requirements

Building Regulations are intended to ensure that a reasonable standard of life safety is provided in case of fire. The protection of property, including the building itself, often requires additional measures and insurers will, in general, seek their own higher standards before accepting the risk.

The insurance company FM Global recommends the use of FM Approved roof assemblies as listed at www.roofnav.com and installed in accordance with their Loss Prevention Data Sheets (www.fmglobaldatasheets.com). Specimens of the full roof construction (from deck through to roof membrane) are subject to both external and internal fire test.

The Loss Prevention Certification Board (LPCB) operates an alternative certification scheme (www.redbooklive.com).

2.7. TRANSMISSION OF DAYLIGHT

(for Design see section 3.10)

Rooflights can provide very durable and effective glare-free natural lighting in deep plan buildings. Since their size and position has a significant effect upon drainage and thermal design, it is important to establish the performance requirement at an early stage. Solar gain must now be considered.

2.8. LIGHTNING PROTECTION

(for Design see section 3.11)

Lightning protection is a function of building location, design, materials and internal use. Since lightning protection works are usually part of the electrical contract package, effective integration of the roofing and electrical design is important at an early stage.

2.9. APPEARANCE (for Design see section 3.12)

The overall appearance of the finished roof with its necessary details, plus any decorative surface finish. The durability of the appearance and retention of colour should also be considered. Where the roof is a visible feature, client expectations should be matched with system performance by reference to similar projects and sample panels, as appropriate.

2.10. SECURITY

Required performance in respect of security against access to and through the roof should be established at an early stage as this can influence the selection of roof type and detailing. Buildings such as data centres require this special consideration.

2.11. SUPPLEMENTARY USES

Mechanical and electrical services are often subject to location and capacity change during a building project and during service. In particular, attachment of and services connections to photovoltaic and solar thermal arrays should be designed for change during the lifespan of the roof system. Single ply roof systems are unique in their adaptability to such change. However, the extent of design flexibility likely to be required should be established, to inform appropriate detailing or and to avoid difficult sequencing during construction.

2.12. MAINTENANCE FREQUENCY AND COST

Single ply roofing membranes require no maintenance but it is established good practice to check roofs for damage or debris at least twice per year (preferably in early spring and late autumn) (see 6.0 Maintenance).

2.13. WARRANTY

[S4/08 Guarantees – a checklist for clients & designers](#)

SPRA requires that its membrane and associate component manufacturers offer a minimum ten year product warranty. Longer product guarantee periods may be available as may additional guarantees for workmanship, from either the sub-contractor or via third-party products which include protection from insolvency.

2.14. SAFETY DURING CONSTRUCTION AND USE

(for Design see section 3.17)

In addition to the safe methods of working with materials there is a requirement to protect workers from falls.

The Work at Height Regulations became effective in April 2005 as a result of a European Directive.

Because much of Section 6 of the Construction Health Safety & Welfare Regulations has now been absorbed into these Regulations, activities in compliance with Section 6 will generally be in compliance with the Work at Height Regulations.

The need to provide protection and preventative measures to stop persons falling during the construction phase would be covered and included in the contractors Risk Assessment.

Consideration must also be given to the prevention of falls during the in-service phase of the roof, such as guard rails, safety restraint systems, designated walkways etc, to ensure the reasonable safety of persons who may need to access the roof for inspection of plant, equipment, roof lights etc. These considerations and requirements should be brought to the attention of the CDM coordinator for inclusion in the Health and Safety file.

Risk avoidance is paramount. The new Regulations mark a change of approach from prescriptive requirements to hazard determination by risk assessment on a job-by-job basis, leading to more consideration of the actions required for every different activity where someone is liable to be harmed as a result of a fall, irrespective of height. It is no longer acceptable to assume that there is no risk if the fall is from less than 2 metres. The scope of 'work at height' is that if measures required by the Regulations were not taken, then a person could fall a distance liable to cause personal injury.

Collective + protection		Individual protection + (of a small number of workers)			
Category A1	Category A2	Category B1	Category B2	Category B3	Category C
Permanent structural barriers	Guard rails for occasional access	Fall restraint No PPE* adjustment required (perimeter system)	Fall arrest No PPE* adjustment required (perimeter system with fall hazards)	Fall arrest PPE* adjustment required (ridge system)	Roped access (abseiling) specialist techniques
Risk factor* for a basic trained worker 1	Risk factor* for a basic trained worker 1	Risk factor* for a basic trained worker 2	Risk factor* for a basic trained worker 3	Risk factor* for a basic trained worker 6	Risk factor* for a basic trained worker 10
Worker training to control risk NONE	Worker training to control risk NONE	Worker training to control risk BASIC	Worker training to control risk BASIC	Worker training to control risk ADVANCED	Worker training to control risk SPECIALIST
<p>* Notes PPE: Personal Protective Equipment Risk factor: 1 = low risk, 10 = high risk</p> <p>+ Definitions Collective protection: systems which protect an area, allowing work to take place safely, without the necessity for any direct action by the worker in order to protect himself. Individual protection: systems which require direct action by each worker in order to ensure that he is protected. The level of worker competency required to safely use different categories of system will vary.</p>					

Table 1: Categories of individual and collective fall protection

3. DESIGN

3.1. INTRODUCTION

The principal code of practice for the design of single ply roof systems is BS 6229 'Code of practice for flat roofs with continuously supported coverings'.

This Standard cross-refers to various other more specific Standards and Codes of Practice; these are set out under the relevant design criterion.

Other relevant sources of best practice advice include *Flat Roofing – Design and Good Practice*' (BFRC/CIRIA 1993), Digests and Reports of the Building Research Establishment, SPRA Technical Guidance Documents and other British Standards, as follows:

SPRA Technical Guidance Documents

[SGD2/04 - Safety - Design considerations for reduced risk](#)

[SGD4/06 - Use of Sealants](#)

[SGD5/07 - Non-destructive Testing of Single Ply Membranes](#)

[SGD6/08 - Quality control and use of adhesives for the attachment of vapour control layers, insulation and single ply membranes in flat roofing](#)

[SGD7/10 - Acoustic control within buildings](#)

[SGD8a/10 - Falls and Drainage for single ply roofs – Part 1](#)

[SGD 9/11 - Protection of roofs](#)

British Standards

- BS EN 1991-1-1: Eurocode 1. Actions on Structures. General Actions. Densities, self-weight imposed loadings for buildings. BS EN 12056-3 and the Building Regulations Approved document Part H contain relevant design information to enable precipitation and run-off rates to be assessed and give design principles for gutters.
- BS EN 1991-1-7: Eurocode 1. Actions on Structures. General Actions. Accidental Actions.
- BS EN 1991-1-4 + A1: Eurocode 1. Actions on Structures. General Actions. Wind Actions.
- National Annex to BS EN 1991-1-4 + A1: UK National Annex to Eurocode 1. Actions on Structures. General Actions. Wind Actions.
- BS EN 12056: 'Gravity Drainage Systems inside buildings. Part 3 Roof drainage, layout and calculation'.

Other References

- Building Research Establishment Digest No. 346: 1989 'Assessment of Wind Loads'.
- Building Research Establishment BR262 'Thermal insulation: avoiding risks' 2002 edition.
- The Loss Prevention Certification Board – List of Approved Fire and Security Products and Services. This is known within the industry as the 'red book'. This can be viewed free of charge on the internet at www.redbooklive.com

Specifically Section 2.5.1 refers to 'Roofing products: protection against fire from outside the building. Section 2.5.2 refers to 'Roofing products: protection against fire from inside the building.

- The LPC Design Guide for the Fire Protection of Buildings – A code of Practice for the protection of business. Published by The Fire Protection Association with supporting documents, including 'Essential Principles'. Both documents are published by The Fire Protection Association.
- FM Approvals Standard 4470 for roof assemblies and www.roofnav.com
- FM Global Data Sheets (www.fmglobaldatasheets.com)

3.2. TYPES OF ROOF SYSTEM

3.2.1. Components

A typical single ply roof system comprises:

- Traffic or load resistant finish (if required for functional and/or aesthetic reasons).
- A filter or water control membrane (inverted roofs only).
- [Waterproof membrane](#).
- [Thermal insulation](#) (if required).
- [Vapour control layer](#) (VCL, if insulation required).
- [Deck](#) providing continuous support (may be installed by the roofing contractor).
- [Structural support](#) (generally not installed by the roofing contractor).

Roof systems based on continuous waterproofing are generally divided into the following types, according to the position of the principal thermal insulation (and therefore the temperature of the deck during service).

3.2.2. The warm roof

The principal thermal insulation is placed immediately below the roof covering, resulting in the structural deck and support being at a temperature close to that of the interior of the building. The design should ensure that the deck is maintained at a temperature above that which could cause condensation to occur at this level during service.

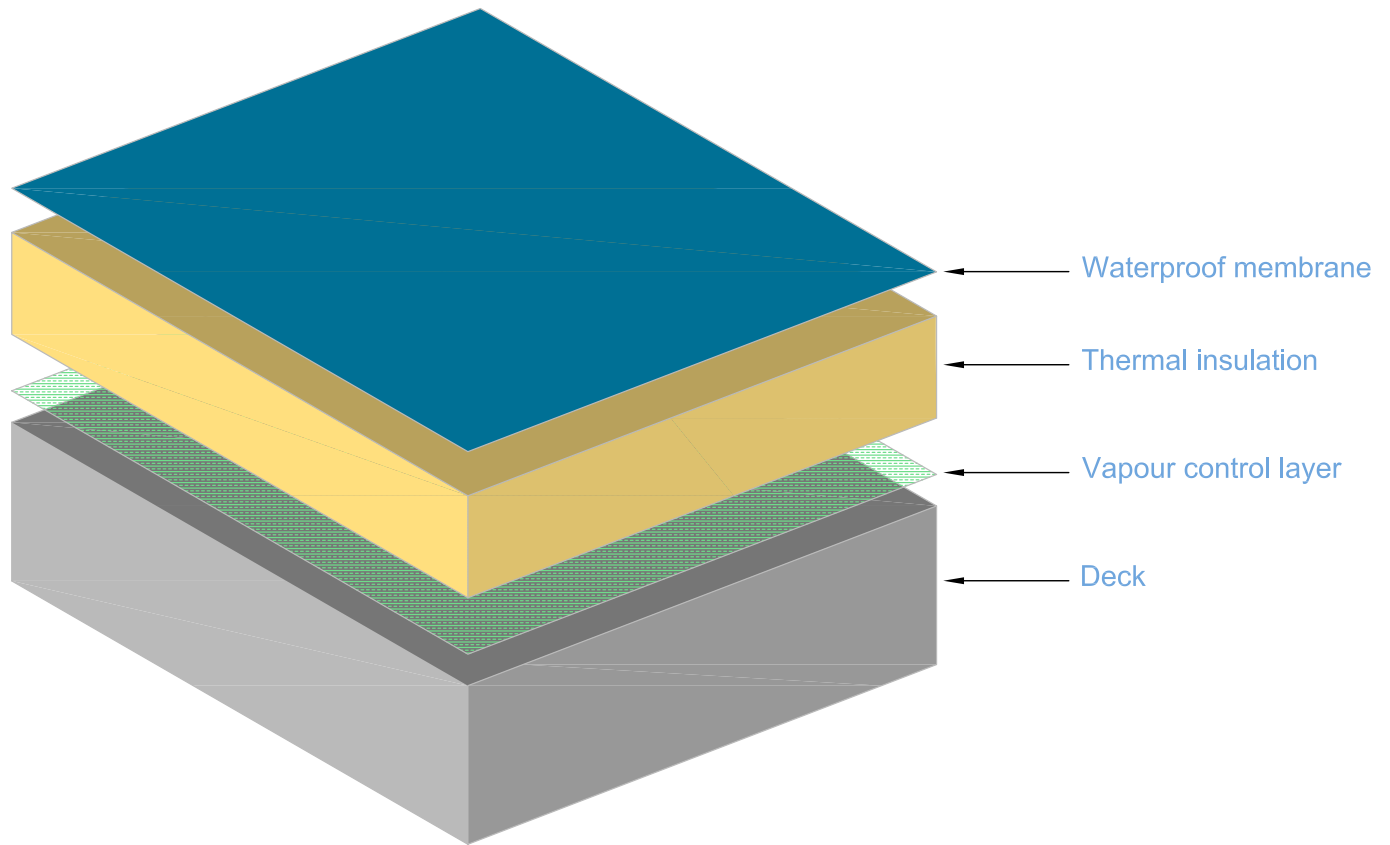

Fig. 1 Warm roof (section)

3.2.3. The inverted warm roof

This is a variant of the warm deck roof in which the principal thermal insulation is placed above the roof covering, resulting in the roof covering, structural deck and structural support being at a temperature close to that of the interior of the building. Generally the principal insulation is secured by separate ballast (paving or stone). However for low wind loading situations proprietary lightweight systems are available comprising of an insulation/ballast composite, which do not rely on separate ballast in the roof field.

A filter layer is required to stop mineral fines passing into and below the insulation joints, to improve rainwater run-off and to reduce the effect of wind uplift on the ballast. Conventional low water resistance geotextiles necessitate a 20% increase in insulation thickness to compensate for losses due to cold bridging by drainage. More recent high water-resistance products (with suitable performance certification) allow a much lower penalty of approximately 3% (depending on the product). By reducing insulation flotation loads, these products may also allow reduced ballast depth (and therefore load) to be used. It is essential that the drainage design facilitates the rapid transfer of rainwater across these products and to rainwater outlets.

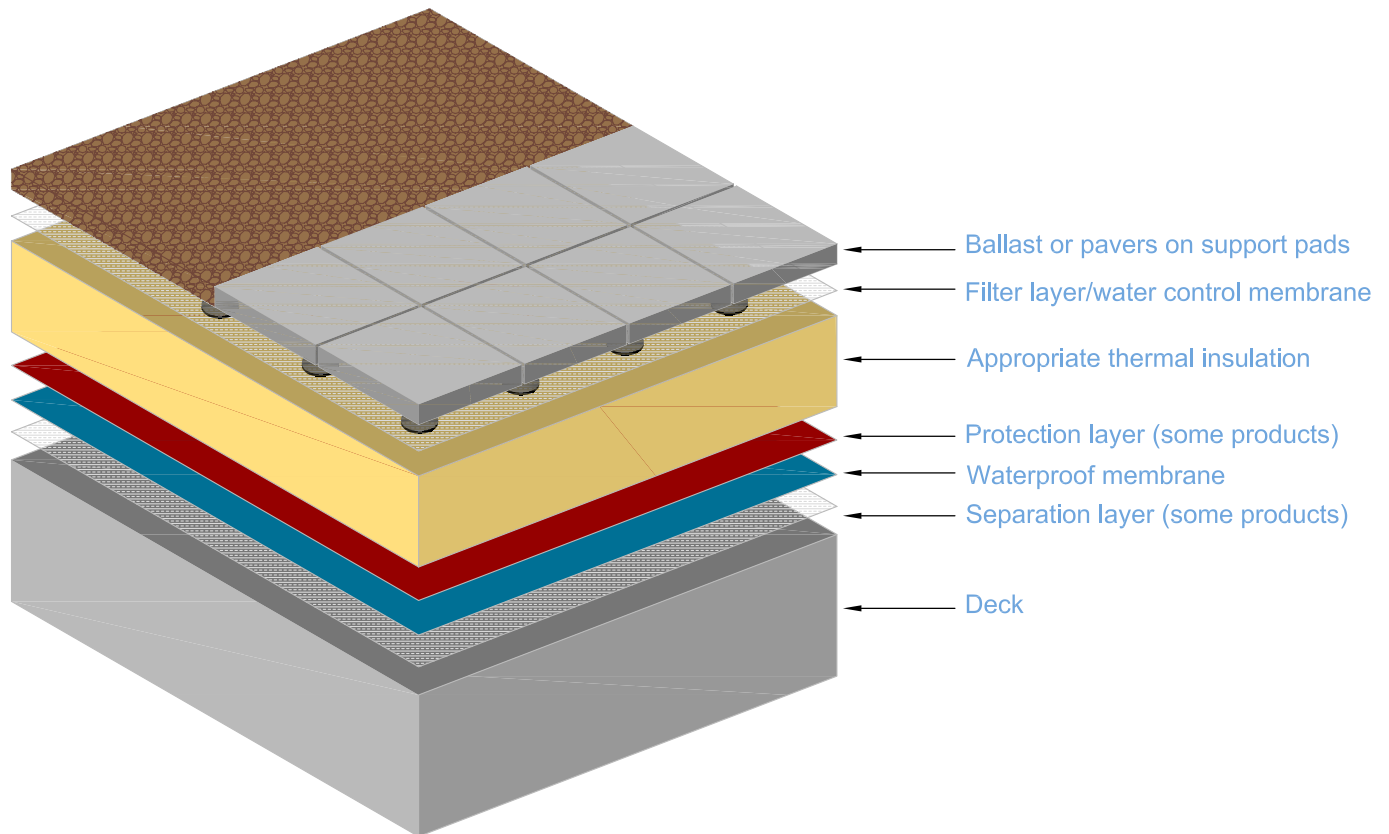

Fig. 2 Inverted warm roof (section)

3.2.4. Roof gardens or 'green/living roofs'

Green Roof Organisation (GRO)

There are four discernable types of green roof construction:

- **Intensive** – Roof gardens designed for mainly recreational use, comprising both hard and soft landscaping. These could include for example, ground level podia, plazas, terraces, lawns, flower-beds and raised planters. Normally constructed on concrete decks due to the imposed loading to the structure, design considerations must include saturated load, upstand height, irrigation, maintenance and safe access.
- **Simple-Intensive** – low maintenance planting with pedestrian access. Typical planting would include lavender or heathers that would still require some irrigation and maintenance. Access provided by paved walkways.
- **Extensive** – low growing, drought tolerant planting cultivated in lightweight substrate growing medium. Available as pre-cultivated vegetation blankets or selected plants either manually plug-planted or hydro-planted, where the seeds/cuttings are sprayed on to the growing medium. Planting generally consists of alpine species such as sedum, together with herbs, grasses and moss. Irrigation only required on steep slopes and/or exposed locations.
- **Brown/Bio-diverse** – designed to replicate natural habitats for endangered wildlife using materials reclaimed from the site being developed. For example, materials from building demolition might be used as a substrate and left to see what planting develops naturally. Surface features may include dead tree branches, coiled rope, large and small boulders etc. No maintenance or irrigation required.

All waterproofing membranes used for green roofs should be independently certificated for such use and demonstrate long term resistance to root penetration and micro-organisms. The current recognised standard in Europe is the German 'FLL' and the UK guide published by the Green Roof Organisation (GRO) (see references). Green roof design requires early and close coordination between those providing the roof and the landscaping.

Insurers will also often have additional requirements for green roofs in respect of property protection. One example being FM Approvals standard 4477.

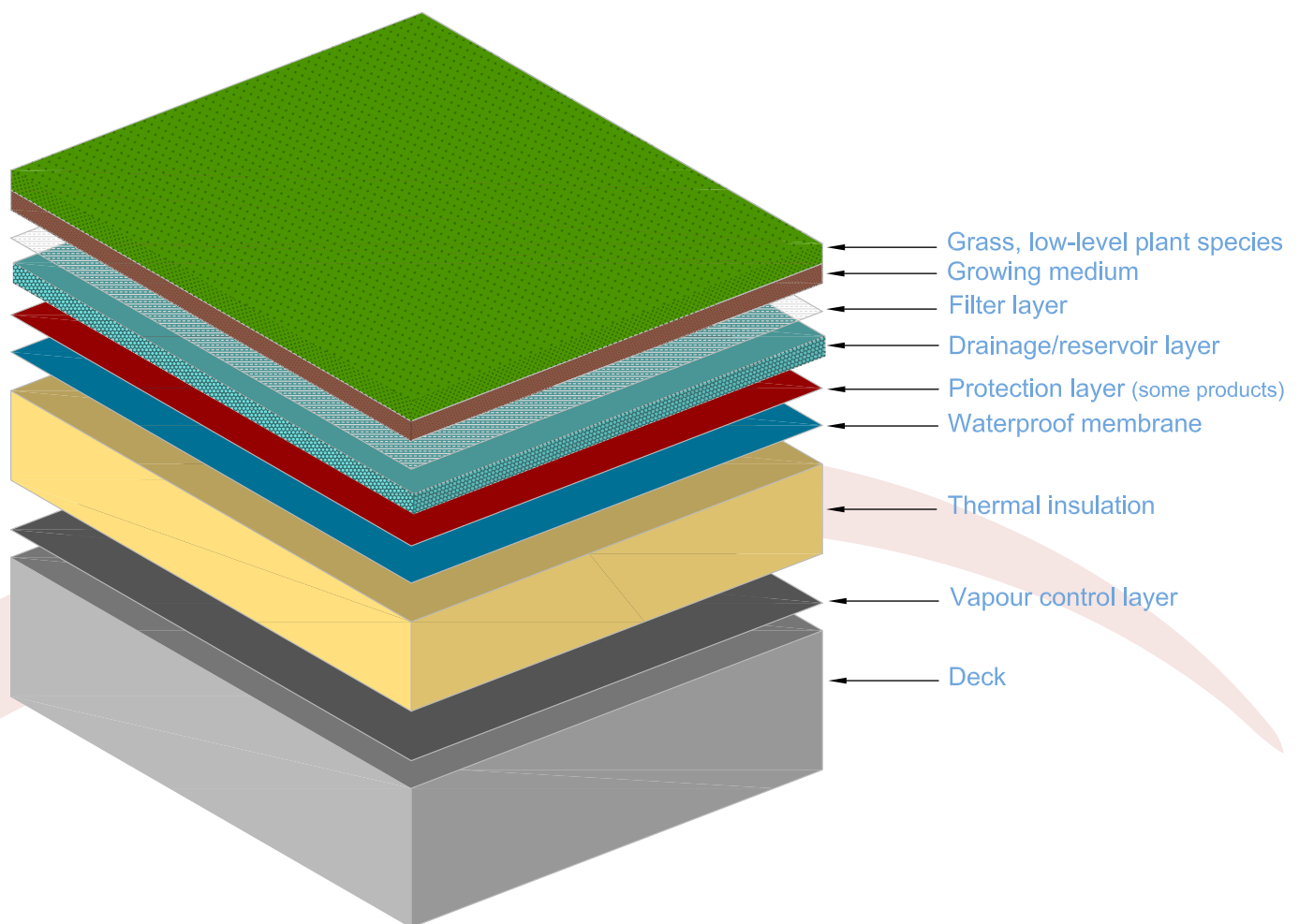

Fig. 3 Green roof - (Warm roof type) (section)

3.2.5. The cold roof

The principal thermal insulation is placed at or immediately above the ceiling (i.e. below the deck), resulting in the roof covering and structural deck being substantially colder in winter than the interior of the building. The structural support will typically form a 'cold bridge' between the high and low temperature zones of the construction. It is very difficult to insulate a cold roof system to current mandatory levels without introducing cold bridges and/or increasing the risk of condensation accumulation within the system. In addition, the mandatory requirement for uninterrupted external air circulation limits the application of the system where abutting elevations or changes in building geometry occur. Therefore, it is very unlikely to be a feasible option and is not recommended.

If an existing cold deck roof is refurbished, it is important to ensure that the ventilation requirement is achieved, whether or not the level of insulation is to be increased. It is also not feasible to introduce vapour control and insulation below an existing structural deck, of concrete for example. If, during refurbishment, a cold deck roof is converted to a warm deck roof (by placing insulation above the deck and closing off the ventilation) it is necessary to provide at least as much thermal resistance above the deck as was previously provided below the deck. A condensation risk calculation should always be carried out in such circumstances to ensure that the deck is above dew point during service.

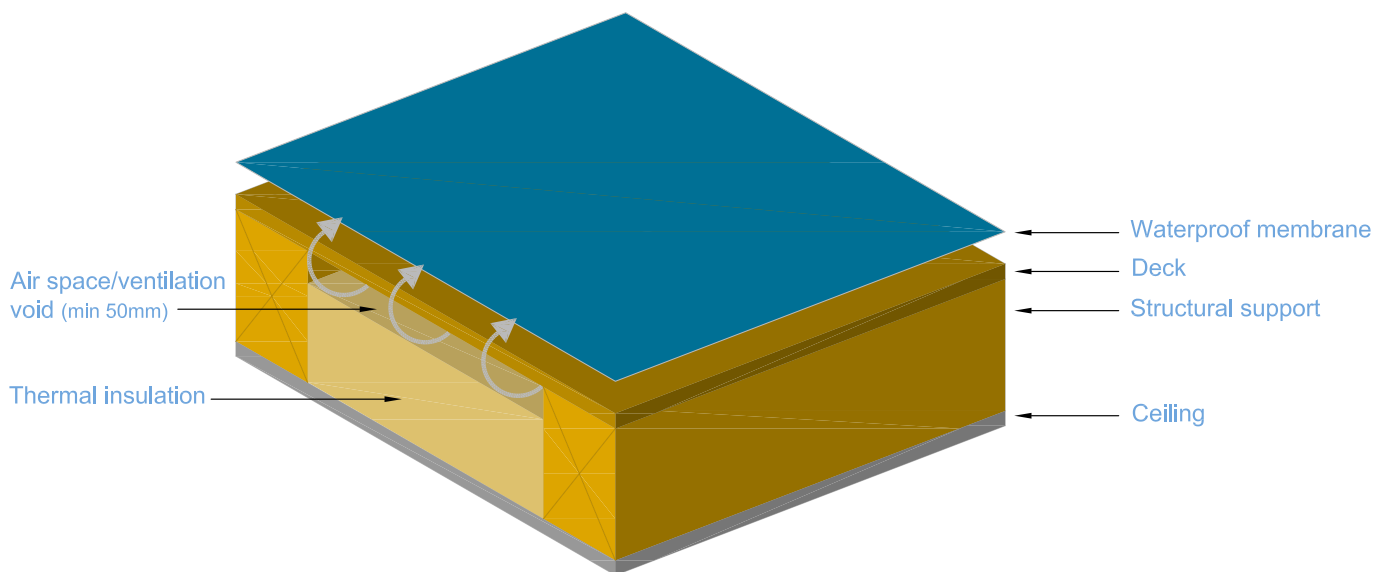

Fig. 4 Cold roof (section)

Many roofs combine the features of two or more of the roof types previously described. Examples include structural decks of high thermal resistance combined with additional insulation and existing roofs to which thermal insulation is added. Once assessed in terms of their thermal and water vapour transmission characteristics, such roofs will generally fall into one of the categories described.

In some constructions the waterproofing layer is placed between two layers of insulation, combining the properties of warm roof and inverted warm roof construction. This form of construction is generally known as a 'duo roof'.

3.3. FALLS

SGD8/13 – Falls and drainage for single ply roofs

Since the primary function of the roof is to exclude water, it is important to consider how best to direct this into the drainage system. Ponding on membrane roofs should be avoided because:

- It encourages the deposition of dirt and leaves which can be unsightly, may obstruct outlets and/or become a slip hazard.
- In the event of damage, the interior will suffer increased water ingress.
- The load may cause progressive deflection of the deck.
- Ice or algae may create a slip or wind hazard, particularly on walkways.

Independent research has shown that roofs with extensive ponding require increased maintenance input.

Membranes are tested for water absorption and watertightness at seams as part of third party certification. However the construction process, including the laying of components and the forming of seams is clearly facilitated in dry, well drained conditions.

Roof falls may be created either during the construction of the deck or alternatively by the use of tapered insulation systems. The former has the advantage that the vapour control layer will also be to fall and will act as a temporary line of defence to water ingress during construction.

BS 6229 states that a minimum finished fall at any point of 1:80 (1.25%) should be achieved. Since adjoining roof planes at 1:80 will meet at a mitre of less than 1:80, the intended finished fall at such intersections should be considered at an early stage.

Design falls should take account of any potential deflection and construction tolerances. In the absence of detailed calculation this may necessitate design falls of twice the minimum finished falls (1:40 or 2.5%). Cut-to-falls systems are often produced to a 1:60 (1.7%) fall or 1:40 (2.5%) fall to ensure that deflection of the deck and/or construction tolerances are overcome.

Consideration should also be given to:

- The available upstand height at the high end of the falls. This may be a limiting factor on the length/size of the roof area to be drained.
- Avoidance of ponding behind wide obstructions to the drained slope such as plant plinths or rooflights.
- Avoidance of gutters by designing with intersecting roof planes.
- Falls between rainwater outlets along a perimeter.

For further information, see [SGD8/13 – Falls and drainage for single ply roofs](#)

3.4. DRAINAGE

SGD8/13 – Falls and drainage for single ply roofs

Drainage design should be based upon calculation given a design head of water (typically 30mm). Rainwater outlet capacity should be taken from properly certificated information provided by manufacturers and the resulting number and layout of outlets should allow for obstruction and drag due to any additional surface finishes such as walkways.

It is not generally necessary to provide separate box gutters where two planes of roofing intersect, or where a single plane falls to an abutment. In the latter case, there will be no fall between outlets so consideration should be given to creating these in the structure or insulation. Box gutters are slow, difficult to construct and introduce unnecessary complexity. The need to maintain a fall in gutters and to comply with Building Regulations may be difficult to achieve.

Single ply membranes are fully compatible with siphonic roof drainage systems. For larger roofs, siphonic drainage offers many advantages:

- Very high capacity, enabling fewer outlets and so less detailing work on site.
- Smaller bore horizontal collector pipework, enabling reduced roof void depth.
- Self-cleaning in many situations.

For further information, see www.siphonic-roof-drainage.co.uk

3.5. SUSTAINABILITY

3.5.1. Environmental Impact

An Ecopoint® assessment was developed by BRE for generic (Polyvinyl Chloride) and FPO (Flexible Polyolefin) in 2008, based on manufacturing data supplied by SPRA members. When set against eleven criteria of environmental impact this produced scores of 14.33 for PVC and 11.35 for FPO. When these ratings were combined with impact data for other parts of the roof assembly (e.g. deck and insulation) they produced the following ratings (irrespective of whether the waterproof membrane was PVC or FPO):

Example - Warm roof

	Commercial/ industrial	Dwellings
Steel deck	A+	A+
Timber deck	A+	A+
Concrete deck – insitu	C	C
Concrete – precast	B	B

Table 2: Green Guide to Specification – Typical ratings for warm roof systems

3.5.2. Durability

Because the sustainability of a roof system depends to a large extent upon its durability, expected durability has been factored into the ratings in Table 2 (above). Single ply membranes supplied by SPRA manufacturer members have independently certificated durability in the range 25-40 years depending on product type and maintenance regime. A single ply roof system should be designed to a service life defined by the client, taking into account such factors as building lifespan likelihood of change-of-use and secondary uses of the roof.

The actual service life will depend on many factors relating to design and maintenance including the following:

- Provision of drainage falls.
- Appropriate design to resist the effects of foot traffic.
- Isolation of building and thermal movement from the waterproof membrane.
- Selection of membrane product type to suit any local airborne contamination.
- Prompt attention to repairs.

3.5.3. Renewables

Cost-effective integration of energy capture equipment with single ply membranes is straightforward, but simplified by early consultation. The following should be considered:

- Careful design if self-ballasted equipment is placed on the roof system.
- Transfer loads to deck directly via structural support or via a framework set on supports.
- Consider the sound transmission effects of turbines and panel arrays.
- Arrange safe and protected access routes to all equipment.
- Provide weathered services access points to avoid late-stage use of sealed collars or pipes.
- Agree minimum access space requirements for repairing equipment of roof covering.

3.5.4. Design to reduce waste

SPRA is committed to the objective of zero waste to landfill. Other parties' commitments to the Waste Resource Action Plan (WRAP) are increasingly precluding the generation of waste on modern sites. Manufacturer recovery of packaging and waste and removal of site waste by the roofing contractor are increasingly common against a background of steeply rising landfill disposal costs. Early consultation between client, designer and roofing contractor is essential for waste minimisation.

Examples include:

- Dimensioning to suit the deck and insulation panel size.
- Off-site preparation of steel decking for roofs of irregular or curved plan.
- Specification of single ply membrane to enable use of field area off-cuts for detailing.
- Avoidance of unnecessary details such as plinths and box gutters.

3.6. THERMAL INSULATION

3.6.1. Building Regulations

England & Wales

Building Regulations Part L implemented in October 2010 consists of the following approved documents:

- L1A (new dwellings)
- L1B (existing dwellings)
- L2A (new buildings other than dwellings)
- L2B (existing buildings other than dwellings)

Note: Part L 2013 is expected to be implemented in April 2014

New build

The 2010 revision to Part L1A of the Building Regulations is tailored to give a 25% reduction in CO₂ emissions on new dwellings, from the 2006 Regulations.

Part L2A is slightly different, in that the total reduction in CO₂ emissions across buildings other than dwellings, follows an aggregate approach, with some building types requiring less than a 25% reduction and some requiring more.

The above documents define the following mandatory limiting backstop fabric U-Values for flat roofs:

- For Part L1A (new dwellings) - Area weighted average 0.20W/m²k
- For Part L2A (new buildings other than dwellings) - Area weighted average 0.25W/m²k

However in practice, achievement of the overall carbon reduction target will require a lower U-value (e.g. 0.18 – 0.12W/m²k).

Refurbishment

Approved documents Part L1B & Part L2B apply to the refurbishment of existing buildings.

When a thermal element is subject to renovation, the whole element should be improved to achieve or better the relevant U- value set out below (for full details see table 3 and table 5 of L1B & L2B respectively), provided the area to be renovated is greater than 50% of the surface of the individual element, or 25% of the total building envelope (When assessing this area proportion, the area of the element should be taken as that of the individual element, not all the elements of that type in the building).

Flat roof or roof with integral insulation: improved U-value
- Area weighted average 0.18W/m²k

Reasonable provision would be to upgrade those thermal elements whose U-value is worse than the maximum threshold value of 0.35W/m²k (for full details see table 3 and table 5 of L1B & L2B respectively) to achieve the improved U-value previously stated above.

Insulated upstands

Section 5 of Part L of the Building Regulations refers specifically to *'the building fabric'* and states that it *'should be constructed so that there are no reasonably avoidable thermal bridges in the insulation layers, caused by gaps within the various elements, at the joints between elements and at the edges of elements.....'*

This section provides guidance to the industry on ways to construct best practice details, to ensure a reduction of heat loss through typical roof and wall junctions, e.g. insulated upstands. Where an approved accredited construction detail (ACD) scheme is available, it may be possible for calculated thermal transmittance values to be used directly into the SBEM/SAP calculations for the building. These can have a significant affect on improving the thermal performance of a building and where ACD's are not used, generic values must be used. Refer to the relevant section of Part L for details.

Scotland

Building Regulations Section 6 (Energy) implemented in October 2010 consists of the following standards:-

- Section 6 (Domestic Energy)
- Section 6 (Non Domestic Energy)

New build

The 2010 revision to Section 6 (Energy) of the SBSA Technical Handbooks is tailored to give a 30% reduction in CO₂ emissions on new buildings (dwellings and non-dwellings) from previous regulations.

The above documents define the following mandatory limiting backstop fabric U-Values for flat roofs.

New dwellings – Area weighted average 0.18 W/m².K.

New buildings other than dwellings – Area weighted average 0.20 W/m².K.

New buildings other than dwellings (shell and fit out buildings) – Area weighted average U-Value 0.15 W/m².K.

However in practice, achievement of the overall carbon reduction target will require a lower U-Value (e.g. 0.18 W/m².K – 0.12 W/m².K).

Refurbishment – Dwellings - New thermal elements (extensions).

There is one of two levels for the new building fabric depending on the thermal efficiency of the existing building, where a building has external walls with a U-Value poorer than 0.7 W/m²k and a roof with a U-Value poorer than 0.25 W/m².K then a U-Value of 0.15 W/m².K

is required for the flat roof. Where the existing wall and roof elements already meet or, as part of the works will be upgraded to meet the U-Values of 0.7 W/m².K and 0.25 W/m².K respectively a U-Value of 0.18 W/m².K is required for the flat roof.

Refurbishment – Dwellings - Reconstruction of elements.

Where the build up of the flat roof element forming the fabric is to be altered or dismantled and rebuilt an opportunity exists to improve the level of insulation. If there is no technical risk or other reason which prevents this then the U-Value of 0.18 W/m².K is to be used as the benchmark. If however it is deemed not reasonably practicable at least a U-Value of 0.35 W/m².K for the flat roof is to be achieved.

Buildings other than dwellings - New thermal elements (extensions).

Where the insulation envelope of a building is extended, the new building fabric flat roof element should be designed to a U-Value of 0.15 W/m².K.

Buildings other than dwellings - Reconstruction of elements.

Where the build up of the flat roof element forming the fabric is to be altered or dismantled and rebuilt an opportunity exists to improve the level of insulation. If there is no technical risk or other reason which prevents this then the U-Value of 0.15 W/m².K is to be used as the benchmark. If however it is deemed not reasonably practicable at least a U-Value of 0.35 W/m².K for the flat roof is to be achieved.

3.6.2. Control of condensation

Condensation in a roof construction occurs when moist air is cooled below its dew point. The greater the moisture content of the air (relative humidity, RH), the higher the dew point temperature.

In cold external conditions, as moisture vapour from a heated interior moves upwards through a typical roof system, its temperature drops. Correct design against interstitial (within the system) condensation ensures that either a vapour control layer (warm roofs) or ventilation (cold roofs) is provided to control this process. The former works by acting as a barrier, the latter by dispersal.

Building types

Building uses such as kitchens, swimming pools or shower rooms are at particularly high risk because of high internal RH. Buildings such as school classrooms or community centres that may be heated intermittently and then poorly ventilated because they are closed for security reasons are also at significant risk. See BS 5250 fig B.1 and table B.5.

Conversely, low RH buildings such as warehouses with only background heating or offices with air management systems are at very low risk.

Cold stores can be assessed in similar ways but in reverse, with the external waterproofing also being required to control effectively moisture vapour transmission into the roof system from the exterior.

Increased thickness of insulation in roofs helps to reduce the risk of surface condensation on ceilings but it does not in itself reduce the risk of interstitial condensation. Indeed it may increase that risk. The correct design of vapour control is therefore vital for effective roof performance.

Vapour control

In a warm roof the vapour control layer (VCL) is placed on the underside of the insulation. However, the VCL is never totally resistant to moisture vapour transmission or air convection. A small quantity of water vapour passing through the membrane itself or at joints will pass through the insulation system and condense on the cold underside of the waterproof membrane.

Design calculation takes account of this process by ensuring that there is no significant accumulation of condensate within the system over a complete annual cycle of winter condensation and summer evaporation.

Advice regarding the requirement for a vapour control layer should be sought from insulation and membrane manufacturers.

Calculation

BS 5250 describes a method of quantifying the accumulation and removal of condensate during hypothetical winter and summer conditions respectively. This method of calculation has also been adopted for all roof coverings within the scope of BS 6229, which additionally advises maximum levels of annual accumulation in kg/m². All SPRA insulation manufacturer members offer a calculation service in respect of both U-values and condensation risk. However such calculation is theoretical because it is based upon steady state conditions and nominal performance data for roof components.

Guidance is available in Building Research Establishment BR262, BS 5250, and the Chartered Institute of Building Services Engineers (CIBSE) Guide - Volume A – Design Data. Calculation may indicate that a VCL is not required for certain low-risk buildings. In this situation, an unsealed metal deck may provide sufficient control. However, such a roof may not provide sufficient resistance to air leakage, thus still necessitating a VCL.

All SPRA Associate members supplying insulation are committed to the TIMSA/BBA *Competent Persons Scheme for the calculation of U-value and condensation risk analysis*. www.bbacerts.co.uk

Reducing risk

Particular consideration should be given to the following:

(a) Warm roofs

- Avoidance of cold-bridging across components with high thermal resistance.
- Avoidance of cold bridging due to gaps in insulation.
- Avoidance of areas with reduced thermal resistance (e.g. box gutters must achieve a minimum U-value of 0.35W/m².K unless it can be demonstrated by reference to BS5250 that condensation will not occur during service).
- Avoidance of air movement through and across the roof system.
- Continuity and termination of vapour control layer at upstands and details generally.
- The effect of penetrations through the vapour control layer.

(b) Inverted warm roofs

- Avoidance of surface condensation on lightweight decks.
- Maximum possible drainage above insulation by designing the deck to a fall.
- Use of a water control membrane beneath ballast.
- Avoidance of cold bridging due to gaps in loose-laid insulation.

(c) Cold deck roofs

- Clear routes for through-ventilation.
- A minimum 50mm gap between the underside of the deck and the top of the insulation.
- Adequate openings for ventilation at each end of the roof.

3.6.3. Control of air leakage

The air tightness of the building fabric should meet the requirements set out in the Building Regulations Approved Documents L1A and L2A (England & Wales) and SBSA Section 6 (Scotland).

The measured air permeability should generally be no worse than the *limiting air permeability* value of 10m³/h.m² at 50 Pa, however the design air permeability value required for each individual building will be set at design stage and may well be lower in order to achieve the TER (target emission rate) for the building. In order to demonstrate that acceptable figures have been achieved, the Building Regulations impose a requirement for pressure testing. Refer to the appropriate Approved Document for guidance.

In a single ply roofing system, effective sealing against air leakage is achieved by either:

- A sealed deck (concrete or steel, with appropriate sealing at perimeters and penetrations by incorporating sealant in the side and head stitching of the steel decks), or (more commonly and easily, but also vulnerable to damage during the construction process).
- A vapour control layer which, if properly sealed to the building perimeter and all penetrations should provide a satisfactory seal.

Tests have shown that mechanical fasteners driven through the vapour control layer will not affect permeability significantly because the insulation is compressed onto the vapour control layer at each fastening point.

It is anticipated that whilst it is relatively easy (with sound design and construction) to achieve less than the current mandatory maximum permeability, the requirement is expected to become more onerous with future revisions of the Building Regulations.

3.6.4. Resistance to solar radiation

Depending upon the membrane selected, solar heat gain may significantly affect the performance of the roof system. Polymeric single ply membranes designed for exposed applications are available with high reflectivity and resistance to UV ageing. The very slow degradation process is such that a high proportion of initial reflectivity is maintained during long service, depending on the local environment and cleaning regime. Manufacturers can provide specific data as required.

Ponding on light coloured membranes will inevitably cause dark areas which will be subject to increased heat gain. These may reduce the efficiency of some photovoltaic systems. Similarly, dark coloured membranes will transmit more heat to the roof system than those with increased reflectivity.

Insurers will also often have additional requirements for roofs incorporating photovoltaic systems in respect of property protection.

3.6.5. Selection criteria

The designer should determine the type and thickness of the insulation and any integral or separate overlay by reference to the performance criteria listed below.

- Required thermal transmittance ('U-value') of the roof.
- Compressive strength (where permanent plant, equipment or loads from roof traffic will be applied directly onto the roof surface).
- Compatibility with other roofing components.
- Required fire resistance.
- Acoustic performance.
- Cantilever capability.
- Free span capability.
- Suitability for roof traffic both during and after construction.

- Suitability for proposed method of attachment.

Additionally for inverted warm roofs:

- Water absorption.
- Correction factors for the cold bridge effect of drainage (rainwater cooling)
- Effect of wind uplift/flotation
- Resistance to freeze/thaw.

SPRA requires that its membrane manufacturers provide product only in systems where the insulation selected conforms to the relevant British Standard or European Standard or is certified by the British Board of Agrément.

3.7. ACOUSTIC DESIGN

SGD7/10 - Acoustic control within buildings

Design of the roof structure should take into account the type of acoustic control required.

Sound absorption within buildings is important for building categories including manufacturing plants, offices, convention and sports halls where sound reflection may become a problem following occupancy. This may be achieved using a combination of insulation boards in conjunction with perforated decking, acoustic ceilings or other sound reduction measures.

The roof structure may alternatively be required to provide sound reduction from external sources such as, heavy traffic or aircraft, which can be accommodated through the use of acoustic materials of appropriate compressive strength in combination with increasing the unit mass of the roof construction, for example by using a mass layer.

Approved Document E – Resistance to the passage of sound, 2004 Edition, requires the construction of new school buildings to meet appropriate acoustic standards. Building Bulletin 93 'The Acoustic Design of Schools' produced by DfES, outlines the methods of compliance. Section 3 of BB93 requires designers to consider the effect of impact noise from rain on the roof. With regards to Health Facilities, in 2008, Health Memorandum HTM 08-01 set out targets for designers to deal with rain noise. Excessive noise from rain on the roof can occur in buildings where the roof is made from profiled metal cladding and there is no sealed roof space below the roof to attenuate the noise.

Lightweight roof construction including single ply membrane in combination with acoustic material or alternatively acoustic ceilings, will offer significant sound attenuation and thereby assist in meeting the necessary requirements determined by an acoustic consultant.

It is generally not advisable to place external air handling plant directly on the roof surface for reasons of satisfactory weatherproofing (see section 3.16); in lightweight construction this may also contribute to sound transmission. However this should not be necessary given

the ease with which single ply membranes can be detailed around vibration-absorbent mountings.

Advice with regards individual constructions is available from SPRA insulation manufacturer members.

3.8. RESISTANCE TO LOADING

3.8.1. Live loading - Wind

At the earliest possible stage, the wind load acting on the roof should be calculated as recommended in BS EN 1991-1-4 and the UK National Annex. Calculation should be based upon building height, site elevation above sea level, site topography, distance from hills and urban areas, building design life and roof design. Separate calculations for different wind directions may be necessary.

The effect of openings in the building such as warehouse doors must also be considered. Complexities such as canopies, barrel vaults and the effect of shadow zones must also be considered.

The roof and membrane attachment design will respond to this design load with appropriate safety factors.

Once design wind load has been established, the attachment method for each impermeable layer in the roof system must be selected to exceed this load (see 3.15.1).

Membrane manufacturers should be consulted wherever a photovoltaic or solar thermal panel array is to be self-ballasted on a single ply membrane because this will affect the membrane's performance under wind loading.

Manufacturers should be consulted on a job-specific basis to establish the bond strength of adhesives used to secure the insulation and/or single ply membrane. This should make allowance for the fact that a full bond is rarely achieved between a flat deck and a rigid insulation. An even distribution of bond is the critical factor.

In designs with high wind load, supplementary mechanical fasteners may be required. Special consideration of design against wind load should also be applied where a bitumen sheet vapour control layer is bonded to the crowns of a metal deck in a fully adhered design. The minimum contact area recommended on a profiled metal deck for bonding should be >49%.

FM Approved roof assemblies require additional consideration due to property protection considerations. Calculations in accordance with BS EN 1991-1-4 are permitted so long as they are supplemented by certain conditions specified in FM Global Data Sheet 1-28.

3.8.2. Live loading - Access, foot traffic and construction process

[SGD 9/11 - Protection of roofs](#)

All materials developed for single ply roofs are capable of withstanding occasional, light, foot traffic for inspection purposes.

Where walkways are to be provided for servicing roof top equipment, the obvious direct route should be protected since this is the route that will be taken. The route should be well clear of areas which might be prone to temporary ponding and be finished with a non-slip surface. A handrail or fall arrest system may be an additional requirement [SGD2/04 - Safety - Design considerations for reduced risk](#). The membrane and insulation manufacturers should be consulted for advice on supplementary load-spreading sheets below the waterproofing where traffic is frequent.

Balconies and podia require special consideration regarding access for the elderly, partially sighted or disabled. For example, level access may be required from external doors, requiring special detailing. Pebble or soft margins at the perimeter of paved areas must be protected from wheeled equipment by a suitable kerb. [SGD8/13 - Falls and drainage for single ply roofs](#)

During construction considerations include:

- The distribution of roof access points and the effect of repeated loads on the system at the stepping on/off location.
- Load-spreading protection will usually be required. The most effective protection is timber panels such as plywood or oriented strand board with taped or linked joints, laid on a geotextile fleece. Re-usable, rolled reinforced mats are available and are recommended since they reduce waste and cost but their suitability/compatibility should be checked with the membrane manufacturer.
- The location of plant and the provision of heavy-duty walkway sheets to protect the waterproof membrane.

Even on non-access roofs, the construction process itself places demands upon the resistance of the system to repeated loads; it should be a major consideration in design and product selection.

3.8.3. Dead loading - Plant and equipment

The design objective should be the transfer of loads from permanent plant and equipment directly to structure either through a bridging structure taken to elevations or by piers penetrating the roof system (with appropriate measures to avoid cold bridging).

In the latter case, the pier section must facilitate the waterproofing process or be constructed with an integral flashing. It is very difficult and therefore costly to waterproof an I-section effectively, but a circular section is simple. If equipment dead load is to be applied to the roof system the supports should be demountable and advice of the membrane manufacturer should be sought regarding compression resistance of insulation, and requirements for protection layers.

3.9. FIRE PERFORMANCE

3.9.1. Building Regulations

Single ply membranes produced by SPRA members are generally self extinguishing and, depending on the nature of the roof build up as a whole, can typically achieve an AB or AC national rating when tested to BS 476 – 3 in a warm deck roof system. Ballasted membranes can generally achieve the highest national rating of AA. In all cases, users are advised to request from the manufacturer official test and classification reports from a recognised test and certification laboratory in order to validate performance.

Demonstration of fire performance through European test methods and fire classification systems is allowed by the current AD B (volumes 1 and 2).

There are a number of different fire classification systems described in the various parts of BS EN 13501 *Fire classification of construction products and building elements*. These include:

BS EN 13501-1 *Classification using test data from reaction to fire tests*. This enables classification of each roof component or lining into one of seven Euroclasses (A1, A2, B, C, D, E or F) for Reaction to Fire Performance. Currently BS EN 13956 for single ply covers limits reaction to fire performance to Euroclass E.

BS EN 13501-2 'Classification using data from EN fire resistance tests for systems in the fully developed stages of a fire. For roofs this includes EN 1363, which will eventually replace test method BS 476 Part 22:1987.

BS EN 13501-5 - See section 2.6

Building designers should ensure that the client is aware of interaction with all other relevant legislation. For example, compliance with The Regulatory Reform (Fire Safety) Order 2005 relating to fire safety in non domestic premises. It imposes a general duty to take such fire precautions as may be reasonably required to ensure that premises are safe for the occupants and those in the immediate vicinity.

3.9.2. Insurers requirements

See section 2.6.4.

3.10. ROOFLIGHTS

Consultation on daylight design should be carried out at the earliest stage possible taking into account, building type and use, rooflight type and lighting levels, non fragility, thermal performance, security and aesthetics. Advice should also be sought on the detail and material compatibility for the roof light/roof system interface.

Independent guidance on rooflight design and selection can be obtained through the National Association of Rooflight Manufactures (NARM) www.narm.org.uk

3.11. LIGHTNING PROTECTION

The installation of a well designed lightning protection system on a structure will collect the lightning strike and dissipate it safely to earth. Such design for installations in the United Kingdom should be in accordance with BS EN 62305.

The design process uses a defined formula to establish the need for protection based on the building size, building location, construction materials and the building use. If protection is required, early communication to the lightning protection supplier and/or contractor of the roof system components and proposed method of attachment will avoid sequencing difficulties as the project proceeds.

Care should be taken that:

- The detailing of waterproofing at entry points of the conductor(s) into the roof is weatherproof and durable.
- The conductor is visible for inspection purposes and not hidden by details or plant installations.
- Clips used to secure the conductor tape to the roof should be approved by the membrane manufacturer.

Adoption of BS EN 62305 has led to increased use of finials with wire connections in place of tape. These are secured by gravity, using concrete weights set in compatible thermoplastic trays. The advice of the membrane manufacturers should be sought if these are used on mechanically fastened membranes as they can affect the behaviour of the membrane during strong winds.

Note: At the time this Guide went to press 'A Guide to BS EN 62305:2006 Protection against lightning' is available free of charge from Furse, Wilford Road, Nottingham NG2 1EB or via www.furse.com

3.12. APPEARANCE

Where the roof is a visible feature, client expectations should be matched to the capabilities of the specification by reference to similar, completed projects and/or sample panels. This is particularly important where the roof surface is subject to a low angle of incidence of sunlight. If special measures such as timber panel overlays to insulation are required, membrane manufacturers' advice should be sought.

3.13. SECURITY

Single ply roof systems can be designed to include special security measures to protect against entry or electromagnetic radiation. For example, earthed steel mesh can be incorporated between layers of insulation in warm roof systems.

3.14. COMPATIBILITY OF COMPONENTS

The selection of components within the roofing system should be discussed in detail with the membrane manufacturers to ensure complete compatibility between components, as the incorrect specification may lead to reduced performance or premature failure of the roofing system. The correct choice of insulation is important when fully adhering the waterproofing, especially when solvent based adhesives are being used. The insulation manufacturer or relevant trade association should always be consulted.

3.15. METHODS OF ATTACHMENT

3.15.1. Introduction

The means of attaching the waterproof membrane and thermal insulation to the substrate must be selected only after calculation of wind uplift forces as recommended in BS EN 1991-1-4 & the UK National Annex. If using this documentation for projects outside the UK, national codes of practice must be taken into consideration.

The three principal options for attachment of single ply membranes are:

- Mechanical fastening.
- Adhesion.
- Ballast.

In warm roofs, the thermal insulation may be attached by the same or by a different method from the waterproof membrane. Insulation for inverted warm roofs is restrained by the ballast overlay. Some typical combinations of attachment are shown in Table 3 (below). Selection is based on project-specific factors, taking membrane manufacturer's advice into account.

	VCL	Insulation	Waterproof membrane
1	Laid loose	Mechanically fixed	Adhered
2	Laid loose	Mechanically fixed	Mechanically fixed
3	Adhered	Adhered	Adhered
4	Laid loose	Laid loose*	Ballasted

* The manufacturer may have specific requirements for attachment if the ballast components are not to be laid immediately.

Table 3 Options for attachment of roof system components

The selection of the appropriate method should be on the basis of the following criteria:

- Calculated wind loads.
- The suitability of the deck to receive mechanical fasteners.
- The suitability of the deck to receive adhesive.
- The internal relative humidity.
- The extent and complexity of roof detailing.
- Aesthetic considerations.
- Noise transmission during construction
- Roof slope
- (refurbishment only) The condition of the existing system.

Whatever the means of attachment, mechanical restraint of the single ply membrane is always required at the roof perimeter, at changes of slope and around details. This can be achieved by one of the following:

- A continuous bar secured to the deck or upstand and covered with a flashing.
- A row of individual fasteners secured to the deck or upstand and covered with a flashing.
- Welding the field and vertical membrane to a membrane/metal profile secured to the deck.

3.15.2. Mechanically fixed

A system whereby the membrane is fastened to the deck using a variety of methods which incorporate a thermal break (if insulation is present).

The following methods are available, depending upon the manufacturer:

- (a) In-seam fastening: fasteners are placed in the overlap between adjacent sheets and protected by the welded seam.

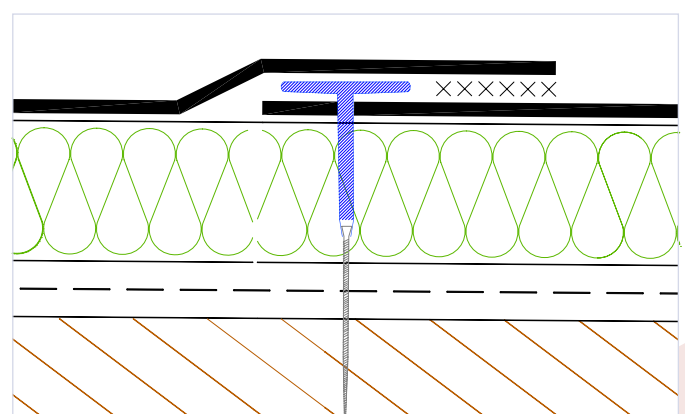
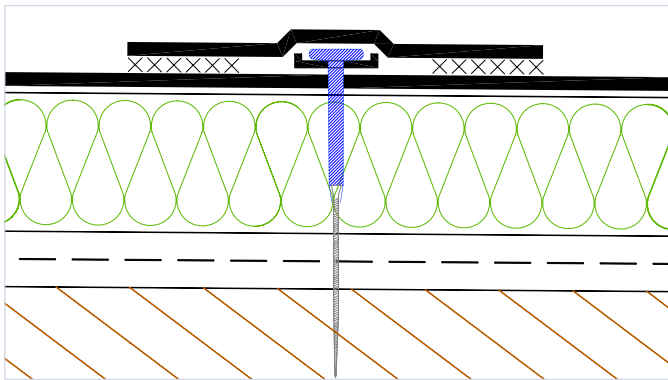

Fig.5 Mechanical fastening – in-seam fastening of membrane

(b) Linear bar fastening: a galvanised steel bar is placed across the width of the sheet and secured with thermal break fasteners before being protected by a cover strip.



[Fig.6 Mechanical fastening – linear bar fastening of membrane](#)

(c) Field fastening: a method of providing supplementary attachment to in-seam or linear bar fastening.

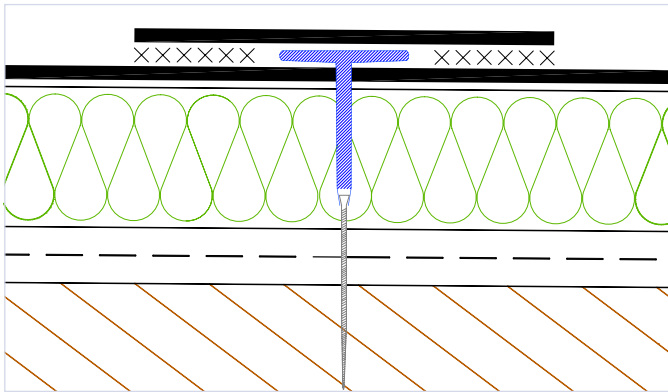

[Fig.7 Mechanical fastening – field fastening of membrane](#)

(d) Disc fastening: the field sheet is adhered to a membrane coated steel plate secured to the deck. Equipment is also available for creating this weld by electrical induction.

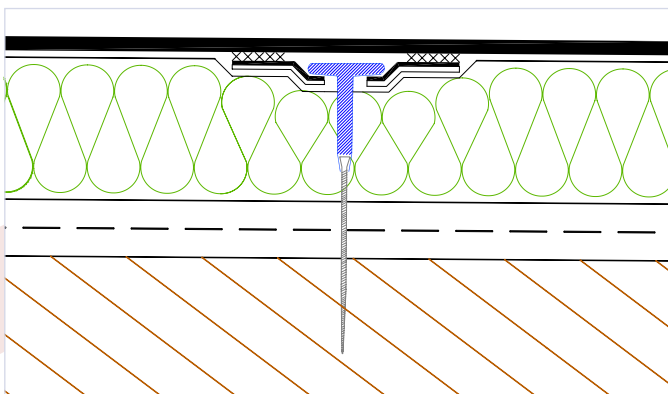

[Fig.8 Mechanical fastening – disc fastening of membrane](#)

(e) Secret fix fastening: the field sheet is welded to a narrow strip of membrane secured to the deck.

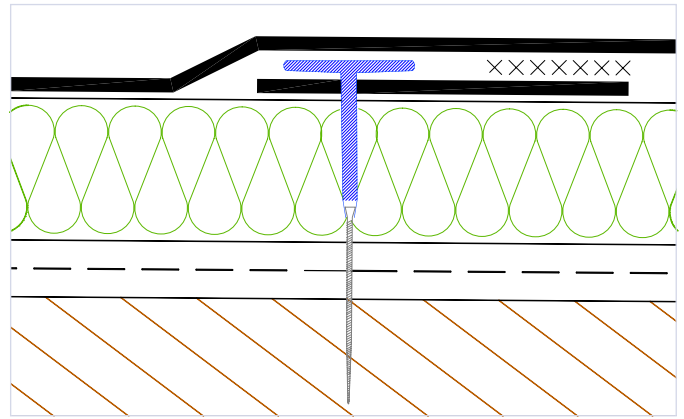

[Fig.9 Mechanical fastening: secret fix fastening of membrane](#)

(f) Vacuum vent attachment: vents around the roof perimeter equalise the pressure above and below the membrane, obviating the need for attachment other than at the perimeter.

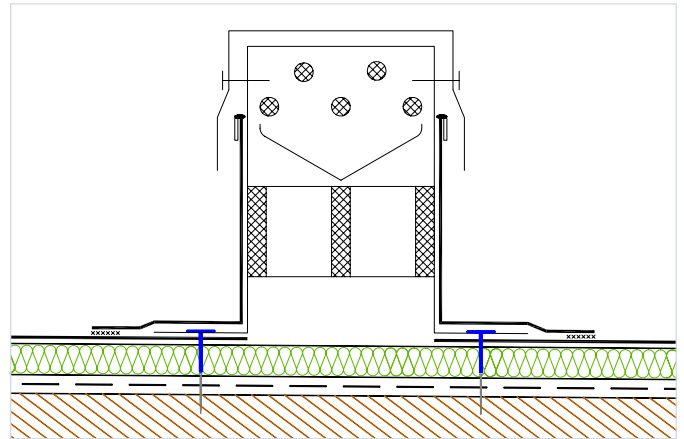

[Fig.10 Mechanical fastening – vacuum vent attachment of membrane](#)

Linear bar fastening

Where the specification calls for metal bars to be fastened through the membrane to the deck as the main method of attachment, the manufacturer will normally supply pre-drilled metal bars and will either supply or nominate the fasteners required. These will have been selected for their resistance to pull-out on the deck and their compatibility with the decking material.

The bars and the fastenings should be installed at the specified intervals with additional fixings at perimeters and penetrations and then weathered as recommended by the membrane manufacturer (normally by covering with detailing strips of the main roof membrane). On metal decks, bars should be applied at right angles to the direction of the decking. If situations arise where this requirement cannot be met, it is essential that the approval of the deck and membrane manufacturers is obtained.

Restraint of the membrane at the perimeter

Mechanical restraint of the single ply membrane is always required at the roof perimeter, at the bottom of changes of slope and around details. This can be achieved by one of the following, depending on the manufacturer:

- A continuous bar (and cord) secured to the deck or upstand and covered with a flashing.
- A row of individual fasteners secured to the deck or upstand and covered with a flashing.
- Welding the field and vertical membrane to a membrane/metal profile secured to the deck.

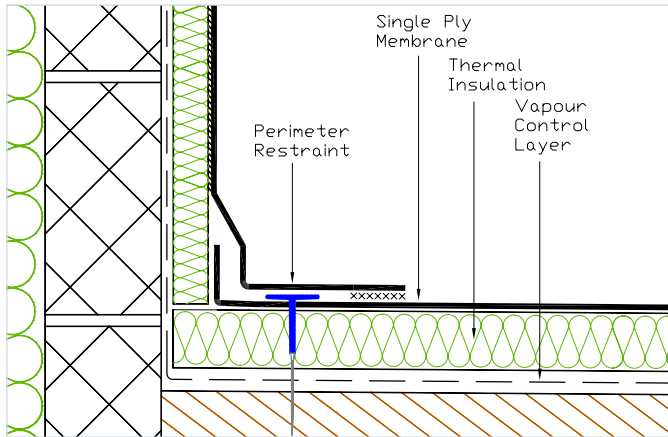

Fig.11 Restraint of membrane by mechanical fastening at perimeter (example)

If the remainder of the roof system is to be bonded it is essential that the design resistance to wind load is also achieved for the attachment of these components.

Irrespective of the wind uplift considerations or distribution requirements for securing the membrane, the fixing of the insulation boards should always be considered separately, unless specifically sanctioned by the membrane manufacturer. Refer to the insulation/membrane manufacturer for advice.

The number and distribution of mechanical fasteners required to fix the insulation boards may vary with the insulation type, geographical location of the building, topographical data and the height of the roof concerned. See Table 4.

Separating layer

On some substrates where no insulation is included in the specification and on inverted roofs, a protection layer (normally polyester or polypropylene fleece) may be required beneath the waterproof membrane.

A separation layer may be required between profiled steel decking and the insulation material. Normally, the vapour control layer will perform this function but if a vapour control layer is not required by calculation or vapour control is achieved by a sealed deck, the insulation manufacturer should be consulted with regard to recommended practice.

Fastening to metal decks

All fixing to profiled metal deck should be to the crown (top) of the deck only and the penetration length should not be greater than the depth of the deck.

Similarly, fasteners through washers will be nominated and the frequency of fixing calculated. Single point fastening to profiled metal decking is usually required to be at right angles to the direction of the deck profile in order that wind load is well distributed. If situations arise where this requirement cannot be met, it is essential that the approval of the deck and membrane manufacturer is obtained.

3.15.3. Adhered

[SGD6/08 - Quality control and use of adhesives for the attachment of vapour control layers, insulation and single ply membranes in flat roofing](#)

A system whereby the membrane is bonded to the substrate using a proprietary cold adhesive. Systems can be either fully or partially bonded depending on the manufacturer. Allowance should be made for the fact that a full bond is rarely achieved and that an even distribution of bond is the critical factor.

Bonding may be achieved by the use of a proprietary adhesive or (very rarely) hot bonding compound, depending on the specification and compatibility of the membrane. Hot bonding is rare because few single ply membranes are compatible with this method and because of general health and safety concerns.

If the remainder of the roof system is to be bonded, it is essential that the design resistance to wind load is achieved at all interfaces in the system.

Adhered membranes may be laid over insulation boards specifically manufactured for adhesive bonding.

Taping of the board joints may be required whenever solvents or solvent-based adhesives are employed in the roof construction, to stop the solvent eroding the cut edge of the insulation product. The requirements of the SPRA insulation manufacturer must be followed in this respect.

Peeling of the roofing membrane caused by the action of high wind loads at the roof perimeter on an adhered membrane roofing system is the most common cause of failure. In order to prevent any tension in the membrane in the roof field or upstand from being transferred to the other as a peeling action, at the roof perimeter, at the bottom of changes of slope and around details, positive restraint is required.

This can be achieved by one of the following:

- A continuous bar and cord secured to the deck or upstand and covered with a flashing.
- Welding the field and vertical membrane to a membrane/metal profile secured to the deck.
- Restraint of the field membrane behind a suitable timber or metal panel.

If a method such as continuous adhesion is used to provide restraint, the membrane manufacturer must demonstrate by independent testing that their system is able to resist peeling of the membrane from the substrate to which it is adhered at up to 2.4kN/m² with a safety factor of two (200%). The test method ANSI/SPRI/FM 4435/ES-1 'Wind Design Standard for Edge Systems Used with Low Slope Roofing Systems' may be applicable.

3.15.4. Ballasted

This is a system whereby the membrane is loosely laid on the substrate and restrained by weight. The weight is supplied typically either by round washed ballast, paving slabs or soil and planting (green roof systems).

Where loose-laid membranes are secured against wind uplift by ballast, the areas of the membrane beneath the ballast may require different properties from the exposed areas. The covered membrane will need to be resistant to bacterial attack but will not need resistance to ultra violet light, whilst the reverse is true for the exposed membrane. Thus different products may be required. Some manufacturers identify each by different colours. To avoid UV degradation, care must be taken to ensure that the correct membrane is used on exposed areas such as upstands.

Timber promenade decking is a popular finish on residential projects but requires care in design, as follows:

- The decking should not be taken to be ballast for resistance to wind load.
- The waterproof membrane should be adhered or mechanically fixed.
- Decking should be secured against displacement under wind load.
- The attachment of the decking should be removable and the deck sections of manageable size to allow cleaning of debris, leaves etc. from beneath the decking.

A separate sheet overlay to the waterproof membrane may be required to protect it from movement of the decking, spillages and timber treatment fluids. Manufacturers' advice should be sought.

Suitable and effective restraint is always required at the roof perimeter, at the bottom of upstands, changes of slope and around details (see 3.15.2 above). This ensures that any tension or movement in the membrane in the roof field or upstand is not transferred to the other, where it could cause a tenting effect or area of high local stress that may become susceptible to mechanical damage.

3.16. DETAILING

3.16.1. General principles

At an early stage in the design process an audit of roof geometry should be carried out to establish what types of details will be required and whether they are to be weatherproof (incorporating an upstand/cover flashing arrangement) or waterproof (providing continuous

waterproofing across the detail). The following key principles should be followed in design of all details:

- Upstands to extend 150mm above finished roof level.
- Downstands (of separate metal flashings) should lap the upstand by min. 75mm
- Construction should achieve independence between different elements and trades.
- Thermal* and fire performance should be maintained.
- A continuous barrier to air leakage should be maintained.
- Reliance on sealant as the sole means of protection should be avoided.

* Section 5 of Part L of the Building Regulations refers specifically to 'the building fabric' and states that it 'should be constructed so that there are no reasonably avoidable thermal bridges in the insulation layers, caused by gaps within the various elements, at the joints between elements and at the edges of elements.....'

This section provides guidance to the industry on ways to construct best practice details, to ensure a reduction of heat loss through typical roof and wall junctions, e.g. insulated upstands. Where an approved accredited construction detail (ACD) scheme is available, it may be possible for calculated thermal transmittance values to be used directly into the SBEM/SAP calculations for the building. These can have a significant affect on improving the thermal performance of a building and where ACD's are not used, generic values must be used. Refer to the relevant section of Part L for details.

The total roof zone depth should be assessed at critical points, such as the top of drainage slopes to ensure that there is enough free upstand available to create the minimum required 150mm of waterproofing protection above finished roof level. It is important that this minimum 150mm upstand is maintained at all points around the waterproofed area, including patios, terraces etc. except at continuous water checks and verges. Balconies are a frequent exception due to the need for level or unobstructed access. Designers should carefully consider the risks of any departure from this criterion. Special design features are essential. [NHBC](#), [Premier Guarantee](#) and [LABC](#) publish specific guidance on the design of balconies.

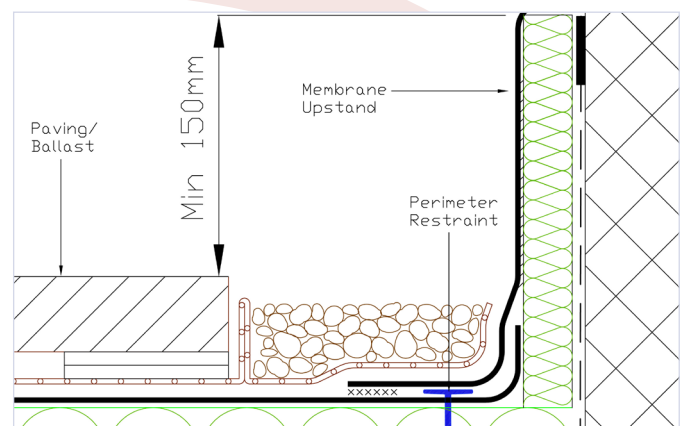

Detail 1 Upstand – minimum height

Where a surface finish, ballast, paving slabs, or decking is applied to the roof, this minimum height is to be measured from the finished roof surface, not from the waterproof membrane. This applies to both warm and inverted roof construction.

Typical classes of detail are given below together with the design principles to be followed.

Important note: the illustrations are schematic, to illustrate principles. They are not intended to represent any or all manufacturers' specific requirements.

3.16.2. Specific types

(a) Upstands - waterproof

Flashings and upstands to perimeters, (and penetrations through the roof), can be formed from the membrane itself or from membrane faced metal—strictly in accordance with each manufacturer's recommendations.

It is recommended that the upper termination be formed by turning the membrane (or membrane-metal profile) into a suitable chase. Only if no alternatives exist (for example, on reinforced concrete panels) should face-fixed termination be considered. In this case, the termination bar should be sufficiently rigid to avoid distortion between fixings and should provide a trough for filling with high durability flexible sealant. [See SPRA SGD4/06 - Use of Sealants.](#)

If there is a damp proof course in the abutment construction it must be set to discharge above the upper termination of the waterproofing.

(b) Upstands – weatherproof

Weatherproof upstands have the advantage that the membrane upstand is independent of whatever rigid material is used to form the cover-flashing. Thus repair of either does not involve multiple trades. They are also appropriate where membrane-metal profiles are not available for the membrane product or where differential movement is anticipated. However they may be slower to construct. The effect of the detail on thermal properties and air sealing should always be considered.

If there is a damp proof course in the abutment construction it must be set to discharge above the cover flashing.

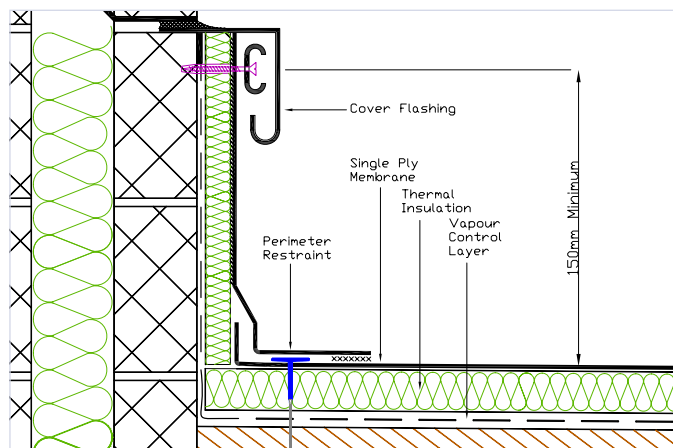

Detail 2 Weatherproof upstand - principles

(c) Upstand-Parapet

Parapets are a special form of upstand in which the capping to the elevation forms either:

- *Weatherproof* protection with the roof system (membrane, insulation, VCL-if required) terminated on the upstand and protected by a separate weathered or flat capping or coping.
- *Waterproof* protection with the roof system taken up the upstand, over a supporting deck covering the elevation and terminated at a drip edge on the exterior.

(d) Waterproof eaves and verges

Drip details at eaves and verges are generally formed from a preformed trim of membrane coated metal secured to a hard edge or through the insulation to the deck. This saves time, improves appearance and reduces variability through pre-fabrication. Separate lengths of this trim are required to accommodate thermal movement, the joint being sealed by a membrane 'butt strap'. In addition, where appearance is important, sheet metal plates may be available for fixing under the trim to ensure that adjacent lengths of trim follow a consistent line.

Where membrane coated metal is not available for the membrane product a non-ferrous edge profile may be part-covered by a membrane flashing.

Membrane manufacturers should be consulted regarding the need for face fixing of deep eaves or verge profiles.

(e) Gutter

As stated in section 3.4, internal box gutters should be avoided wherever possible. Where unavoidable, they can be lined using the roofing membrane to achieve a uniform finish. Membrane coated metal is used frequently to form gutters because:

- It provides continuous support to the gutter sides.
- It provides protection at the upper edge of the gutter walls.

If unavoidable, gutters should be designed in accordance with BS EN 12056: Part 3 and [SPRA Component Quality Standard - Membrane-lined gutters.](#)

(f) Rainwater outlet

Rainwater outlets must be situated at low points and their location changed in the event that the drainage layout is changed. The area surrounding the outlet must fall to the outlet without obstruction. In an inverted roof the high water resistance filter layer must fall continuously to the outlet without obstruction. All rainwater outlets should be designed so as to enable simple visual access for checking and clearing as necessary.

(g) Movement joint – waterproof

Where a building requires structural expansion joints the membrane may have sufficient elasticity to accommodate minor movement within the plain of the waterproofing.

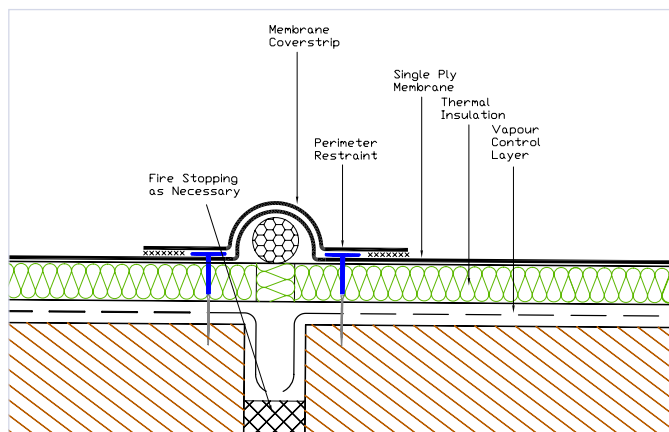

Detail 3 Movement joint – waterproof - principles

(h) Movement joint – weatherproof

In other situations, where movement may be multi-directional and of large amplitude, a weatherproof detail is required. This detail is inherently reliable because movement is isolated from the waterproofing but it does form an obstruction to drainage if the joint runs across the line of fall and it may be difficult to eliminate cold-bridging.

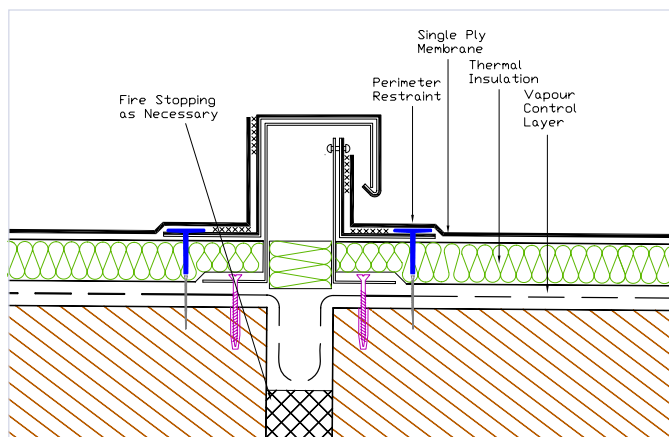

Detail 4 Movement joint – weatherproof - principles

(i) Abutment to masonry - weatherproof

Any abutment to masonry which incorporates a damp proof course (DPC) must be detailed such that the latter discharges above the point of attachment of the upstand flashing to the wall. If not, rain driven into the cavity may pass into the roof system.

(j) Load-bearing plinth for services

In the absence of a load-bearing structure set above the roof field, independent plinths may be required.

The design of the plinth should allow for:

- Equipment to be demounted without affecting the integrity of the waterproofing.
- Protection of exposed edges and corners from accidental damage.

- Sufficient height to allow installation and inspection of the roof membrane adjacent.
- Avoidance of cold bridging into the structure.

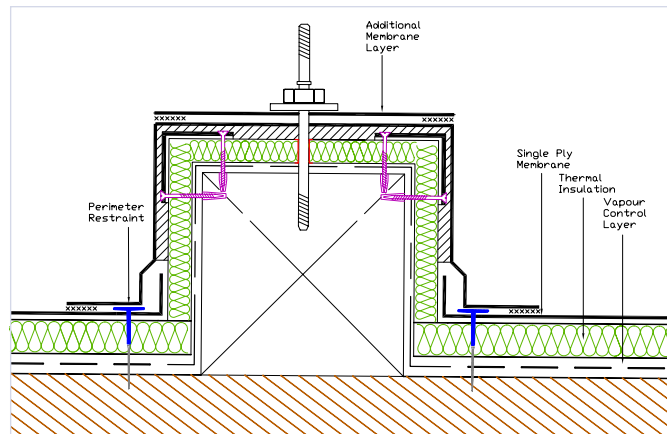

Detail 5 Load-bearing plinth for plant - principles

(k) Pipe penetration

The approach to waterproofing of pipe penetrations is heavily dependant upon membrane type.

The design of penetrations should allow for:

- Isolation of the waterproofing from hot flues.
- Differential movement as required between the penetration and roof system.
- Mechanical clamping or apron flashing at the upper termination of the pipe collar.
- Control of air leakage.

Multiple pipe penetrations should be set in a raised plinth with either a purpose-made cover to fall (preferred) or adequate space between each pipe to enable effective seams to be formed.

(l) Access to balcony or terrace

The requirement of a 150mm waterproofing upstand is fundamental to reliable detailing. However, working with building insurers and the residential sector, SPRA is aware of the requirement for unimpeded access to balconies and roof-level terraces in many designs. In this situation only, the requirement has been reduced to 75mm at the opening, provided that the following conditions are met:

- Rapid removal of rainwater across the width of the opening, by including a proprietary drainage channel in front of the threshold.
- The waterproof membrane extends 150mm height in the door reveal and roof/abutment wall adjacent.
- The waterproof membrane flashing extends fully below the door frame bottom rail and is sealed to it.
- A horizontal gap of minimum 10mm between frame front edge and drainage channel.

- A horizontal gap of minimum 10mm between frame front edge and drainage channel.

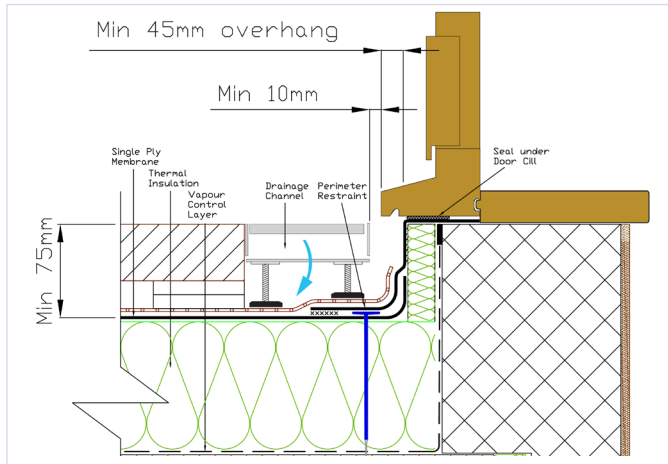

Detail 6 Level threshold – warm roof – principles

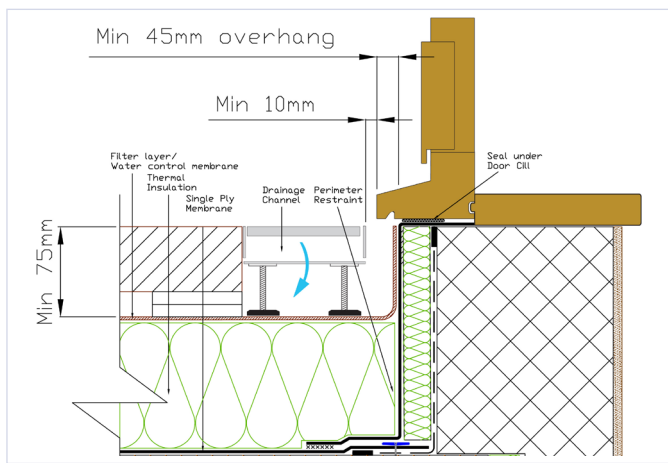

Detail 7 Level threshold – inverted warm roof - principles

3.17. SAFETY DURING CONSTRUCTION AND USE

Safe methods of access and working should be used for the roof installation and ongoing maintenance of the roof and any equipment on it. Prevention of falls is a major consideration and may require the use of edge protection or a safety cable system. If a safety cable restraint or fall arrest system is installed it should have been type tested to BS EN 795 and carry the CE mark. The support posts for the system should be of suitable design to withstand the high potential loads and to allow adequate weathering.

SPRA supports and participates in the Advisory Committee for Roof Safety www.roofworkadvice.info and was a contributor to the 'Magenta Scheme' for safety lines [Part 1 Best practice for use of horizontal safety lines in Roofwork](#) and [Part 2 \(test methods\)](#).

4. MATERIALS

4.1. STRUCTURAL DECK

4.1.1. Introduction

Structural decks can be classified as:

- Panel or sheet (pre-formed, supplied and fixed).

Single Ply Roofing Association
Design Guide for Single Ply Roofing

- Cast in-situ.
- Existing (refurbishment).

This section defines the types of structural roof deck generally available in the context of new roof construction where the designer or roofing contractor is responsible for selection.

4.1.2. Profiled metal sheet

Profiled metal decking typically consists of galvanised steel, coated steel or aluminium that is profiled to provide the necessary strength to suit the span and load requirements. These materials are generally used for lightweight roof systems where rapid installation is required.

When considering the deck profile and the necessity for side lap stitching and metal deck closures reference should be made to the manufacturers of the deck, insulation and membrane.

To provide a sound base for the insulation and waterproofing system and to avoid reduced drainage performance, the mid-span deflection of the metal deck should not exceed 1/200 of the span under uniformly distributed design loads.

The choice of thickness, profile, acoustic perforation and finish of the decking will be dependent on the required span, roof construction, imposed dead and live loading and any aesthetic consideration such as requiring a decorative exposed underside.

Material specifications in the UK are defined in the following documents;

(a) Galvanised steel

Minimum recommended thickness 0.7mm to BS EN 10346 Fe E280G Z275. Typical gauge range 0.7-1.2mm.

(b) Coated galvanised steel

Minimum recommended thickness 0.7mm to BS EN 10346 Fe E220G Z275. Typical gauge range 0.7-1.2mm.

(c) Plain aluminium

Minimum recommended thickness 0.9mm to BS EN 485-2 AA3004 H34. Reference should also be made to BS EN 1396 as appropriate. For mechanically fastened roof systems peel rivets or expanding fasteners, which provide a positive clamping action, should be used.

(d) Coloured aluminium

Minimum recommended thickness 0.9mm to BS EN 485-2 AA3004 H34 and BS EN 485-2 AA3105 H25. For mechanically fastened roof systems peel rivets or expanding fasteners, which provide a positive clamping action, should be used.

4.1.3. Timber/Panels

SPRA recommends that all timber products are responsibly sourced. Timber decking of all types should be specified to suit the load and span capability of the joists and purlins. Timber decking is generally classified into pre-formed sheets and timber boarding. Modern

roof construction typically utilises sheets but it is not uncommon in re-roofing situations to identify traditional timber boarding.

(a) Sheet boarding - Orientated Strand Board (O. S. B.)

A wood panel composed of timber strands orientated in cross directional layers, the choice of thickness is dependent on the span, type of insulation and membrane. For details of design criteria and installation please refer to the panel manufacturer.

Roofing grade OSB should be manufactured to BS EN300 grade OSB/3 and be certificated by the British Board of Agrément or other member of UEAtc. The minimum recommended thickness for the structural roof deck or upstand details is 18mm.

(b) Plywood

For the structural roof deck or upstand details, plywood should be of minimum 18mm thickness and certificated to conform to BS EN 1995-1-1 Eurocode 5. Design of timber structures and to BS EN 636 Plywood, specifications minimum Service class 2 – ‘humid conditions’ or where required Service class 3 – ‘Exterior conditions’.

(c) Timber boarding

New timber boarding should be a minimum 25mm thick and, ideally, tongued and grooved because this maintains its resistance to deflection after natural shrinkage.

(d) Woodwool cement slab

A rigid timber and cement based medium weight panel, which may be reinforced with steel edge channel for longer spans. Woodwool cement slabs should conform to BS EN 13168.

The minimum required thickness is 50mm. The choice of thickness is dependent on the span, type of insulation and membrane. For details on design criteria and installation please refer to the panel manufacturer.

If the panel is to be designed as a contributor to roof system thermal performance then the effect of any metal channel (edge) support should be considered.

Woodwool is very rarely used in new construction. If encountered during refurbishment, specific advice must be obtained from the membrane manufacturer regarding attachment to resist wind loading.

(e) Cement-bonded particle board (CP Board)

It is recommended that CP board is not used, either as a structural flat roof deck, or as a panel substrate for parapet wall details to which single ply membrane is either mechanically fastened or adhered. Both applications require that the wind load is transferred directly from the single ply membrane layer to the CP board, which has insufficient inherent strength to provide adequate structural support. CP board applications on flat roofs with single ply membranes should therefore be confined to the provision of supported mass layers for the provision of additional acoustic performance.

4.1.4. Concrete

Structural concrete decks can be classified as either reinforced (cast in-situ), precast, pre-stressed or lightweight aerated. Each will have a different effect upon cost, contract period and performance. Since concrete decks are installed by roofing contractors only in specific and very rare instances, their inspection and material specifications are not covered in this guide.

Information on span capability and installation requirements of precast panels can be obtained from manufacturers.

Information on the location of required movement joints should be obtained early in the design process as they have implications for drainage layout and detailing.

Precast panels installed to a fall can provide a simple layout but without cross-falls. In-situ concrete is more difficult to lay to a fall and it is more common to create falls in the insulation (warm roofs only) or by use of an additional screed. Bitumen-bound screeds are not generally suitable for single ply roof systems.

Information on compressive strength, resistance to point load and drying periods of wet screeds can be obtained from suppliers and relevant trade associations.

4.1.5. Composite metal decks

Composite decks comprise a polyisocyanurate (PIR) insulation core factory-adhered onto a suitable profiled steel liner sheet. Panels are generally available with the following top sheet options:

- Insulated panel with a membrane top sheet; waterproof membrane factory-applied.
- Insulated panel supplied with a 50micron foil top sheet; waterproof membrane mechanically fastened on site.
- Insulated panel supplied with a polyester/cellulose mat reinforced with glass fibre; waterproof membrane adhered on site.
- Insulated panel with plain galvanised steel top sheet; waterproof membrane mechanically fastened or adhered on site.
- Insulated panel with plastisol/polyester coated steel top sheet; waterproof membrane mechanically fastened or adhered on site (seek advice from the membrane manufacturer). A separation layer may also be required.

Some composite panels are also available with deep deck profiled liner sheets suitable for larger spans and extensive or intensive green roof solutions.

4.1.6. Structural insulated panel systems

Pre-fabricated structural insulated panels systems (SIPS) generally comprise an insulated core of polyisocyanurate (PIR) or Polystyrene (EPS) sandwiched between two skins of plywood (to BS EN 636 Service Class 2 minimum, higher Service Class plywood may be required,

depending on climatic conditions, and should be defined by the specifier) or Orientated Strand Board (to BS EN 300 OSB3).

Membrane can be adhered on site or may be mechanically fastened to the panel. Suitability for mechanical fixing depends on deck thickness and quality and is subject to confirmation of the suitability of attachment by both the panel and membrane manufacturers.

As it is likely to be impractical to install a vapour control layer on the warm side of the insulated panel, the designer should seek the manufacturer's advice on how to prevent vapour transmission. Special attention should be given to the long term sealing of all the panel joints, abutments and penetrations. Reliance on site-applied foams is not recommended.

4.2. VAPOUR CONTROL LAYER (VCL)

Where a vapour control layer (VCL) has been shown by calculation to be necessary then this could consist of a polyethylene membrane, reinforced bitumen sheet or polymeric/foil self-adhesive sheet. In either case, the inclusion of metal foil laminate greatly increases the water vapour resistance of the product and may be required for high humidity applications.

Independently certified test data for the product should verify that it has adequate performance against the following criteria:

- Resistance to heat ageing.
- Resistance to UV (during construction and storage).
- Tear resistance.
- Consistent vapour resistance.
- Tensile strength.

Polymeric vapour control layers such as polyethylene are generally laid loose and restrained by the mechanical fasteners for the insulation or by the ballast on the system as a whole. Side and head laps are sealed with a non-setting adhesive once the sheets have been set out.

Bituminous vapour control layers are bonded in hot bitumen and may be fully or partially bonded. Side and head laps are sealed with hot bitumen during the laying process. There are also bitumen sheet products available for application by proprietary adhesive, gas torch or by self-adhesion. Both require skill and appropriate site cleanliness and safety conditions. Manufacturers' advice should be sought.

When using torch-on bitumen products consult guidance published by the National Federation of roofing Contractors.

4.3. THERMAL INSULATION

4.3.1. Classification

Thermal insulation products for single ply roofing are classified generically in terms of their behaviour as follows:

- Cellular materials which derive their performance from the thermal resistance of gas(es) trapped in the cell structure and from the thermal resistance of the cell walls.
- Fibrous materials which derive their performance from air trapped between fibres laid perpendicular to the direction of heat flow.

For application in warm roof and inverted warm roof systems, thermal insulation is manufactured and supplied as a rigid board because it must be capable of withstanding loads during construction and service. Boards range in size from 600 x 1200mm to 1200 x 2400mm for flat boards or 1200 x 1200mm for tapered products.

Insulating screeds on concrete decks can also contribute to overall thermal resistance. However, their contribution is limited unless an impractical thickness of screed is proposed. In addition, the effect of a further wet process on construction time has reduced its popularity.

4.3.2. Cellular materials

Cellular thermal insulation materials are composed of materials of polymeric and mineral origin.

Polymeric materials

- Polyurethane PUR
- Polyisocyanurate PIR
- Polystyrene - expanded EPS
- Polystyrene - extruded XPS

Mineral materials

- Cellular glass CG

(a) Polyisocyanurate foam (PUR/PIR)

SPRA Component Quality Standard – Rigid Urethane Foam

Rigid urethane foam comprises a combination of polyurethane (PUR) and polyisocyanurate (PIR) thermoset foams with closed cell structures, produced by a chemical reaction during which a blowing agent is added.

Rigid urethane foam roofboard should comply with BS 4841: Part 4. Part of this Standard is replaced by EN 13165 Thermal insulation products for buildings - factory made rigid polyurethane products.

(b) Polystyrene – Expanded

SPRA Component Quality Standard – Expanded Polystyrene – Warm deck roofs

SPRA Component Quality Standard – Expanded Polystyrene – Inverted warm deck roofs

Expanded polystyrene is produced by fusing together expanded beads of polystyrene in a high pressure steam environment.

Boards should comply with BS EN 13163 Thermal insulation products for buildings - factory made expanded polystyrene products. Expanded polystyrene is not compatible with PVC membranes. Either a fleece-backed membrane or a separation layer will be required in warm roofs. Special products are available for use in inverted roof applications, subject to appropriate certification.

(c) Polystyrene – Extruded

SPRA Component Quality Standard – Extruded Polystyrene

Extruded polystyrene is produced by an extrusion process to create a closed cell structure, which offers a wide range of compressive strengths. Boards should comply with BS EN 13164 Thermal insulation products for buildings - factory made extruded polystyrene products. Extruded polystyrene is not compatible with

PVC membranes. For warm roofs, either a fleece-backed membrane or a separation layer will be required. For inverted roofs a separation layer may be required.

(d) Cellular glass

Cellular glass is manufactured from glass which is crushed to a powder, mixed with carbon and melted at very high temperature to convert the carbon to carbon dioxide which is trapped in the cell structure.

Cellular glass should comply with BS EN 13167 Thermal insulation products for buildings - factory made cellular glass products. The membrane manufacturer should be consulted to ensure that the insulation product is compatible with the other components in the specification.

Insulation type	Minimum size of fastener stress plate	Minimum no. of fasteners per board	Position of fasteners
PIR (see note 1)	Mechanically fastened waterproof membrane: Minimum 50 x 50mm or 50mm dia. (based on minimum surface area of 1963mm ²) Adhered waterproof membrane: Minimum 70 x 70mm or 75mm dia. (based on minimum surface area of 4400mm ²)	4 per 0.6 x 1.2m board (5.55 fixings/m ²) (see note 1) 4 per 1.2 x 1.2m board (2.77 fixings/m ²) (see note 1) 6 per 2.4 x 1.2m board (2.08 fixings/m ²) (see note 1) 8 per 3.0 x 1.2m board (2.22 fixings/m ²) (see note 1)	Pattern to be as per BRUFMA Guidance (see references Section 8.4)
EPS (see note 1)	Minimum 70 x 70mm or 75mm dia. (based on minimum surface area of 4400mm ²)	4 or 5 per board for most board sizes - consult manufacturer 1.2 x 2.4m require min 6 per board or above - consult manufacturer (see note 1)	One per corner (fifth in centre, if required)
XPS (see notes 1)	Minimum 70 x 70mm or 75mm dia. (based on minimum surface area of 4400mm ²)	4 per 0.6 x 1.25m board (see note 1)	One per corner
MW (see note 2)	Minimum 70 x 70mm or 75mm dia. (based on minimum surface area of 4400mm ²)	1 per 1.2 x 1.0m board 1 per 1.8 x 0.6m board (see note 2)	Centre of board

Notes

1. The required number of fasteners shown is the minimum only. Regardless of the membrane attachment method, wind load calculations should be undertaken in order to determine actual fastener requirements in corner, perimeter and field roof areas. These areas should be clearly defined, especially where different numbers of fasteners are required for each zone.
2. The number of fasteners required for mineral wool products is subject to individual membrane manufacturer approval, which should be based on wind uplift testing undertaken by the same. The required number of fasteners may increase for membrane systems bonded to the insulation with adhesive because wind loading acting on the membrane is transferred to the insulation fasteners.

Table 4 Insulation fasteners - minimum area of stress plate, number of fixings and layout.

4.3.3. Fibrous materials

Fibrous materials are composed of materials of mineral or organic origin.

- Mineral Wool MW.
- Mineral Wool (low density quilt) cold roofs only.

(a) Mineral wool

SPRA Component Quality Standard – Mineral Wool

Mineral wool manufacturing processes involve the fusion of the constituent minerals at high temperatures (1,100-1,500°C). The result is a vitreous melt, which is spun or pulled into fibres. Immediately following their formation the fibres are compressed to a predetermined density, bonded together with binding agent and cured to form rigid boards, slabs or roll products non combustible according to EN 13501 Part 1 & BS EN ISO 1182.

Roofing boards are available as either mono-density or dual density products, the latter with increased compression resistance.

Boards should comply with BS EN 13162 Thermal insulation products for buildings - factory made mineral wool (MW) products.

4.3.4. Composite Insulation

One insulation material may be combined with another or with another component in order to achieve an optimum performance in a single product. Examples include:

- Polyisocyanurate insulation with an upper surface of plywood: for use where a very smooth finish is required for enhanced appearance or for improved resistance to point loads.
- Polyisocyanurate insulation with an upper surface of plywood and lower surface of metal foil: a single product providing deck, insulation and vapour control. Special measures are required to achieve continuous vapour control between boards.
- Mineral wool on expanded polystyrene: to achieve thermal resistance at low cost but with improved acoustic or fire resistance.

4.3.5. Other insulation types

The following types of insulation are not currently in use alone with single ply membrane systems, either because they lack the necessary compressive strength or because their thermal performance is insufficient for modern applications:

- Granulated cork.
- Phenolic foam (PF).
- Expanded Perlite (EP).

4.4. WATERPROOF MEMBRANES

4.4.1. Introduction

Several generic classes of polymeric materials have emerged, all of which are suited to the exposure conditions for roofing. However, because of the nature of the material, each has a different spectrum of properties that the manufacturer can modify by changing the formulation, reinforcement/carrier (if any) and production process.

Even within the same class of materials, manufacturers will adopt different approaches to exploit whichever balance of properties meets general requirements or specific market conditions. In these latter cases, a particular material can, for example, be complimentary to the type of roof construction, the attachment method or the required performance.

The nature of single ply material ensures satisfactory physical properties over a working temperature range of below -30°C to above 80°C, which exceeds all UK environmental conditions including allowance for solar radiation and cooling. Single ply membranes can be jointed by hot air, solvent welding, or adhesive tapes depending upon material type and manufacturers' preferences.

4.4.2. Product certification

The British Board of Agrément certificate single ply material and systems, based upon test methods that have a commonality throughout the EEC. Their investigations focus on the confirmation of a manufacturer's own test data, with limited testing conducted independently. On the basis of this and independent test data and the as-built history of the product, certification bodies will provide a statement of the anticipated durability of the product provided it is installed in accordance with the manufacturer's instructions.

4.4.3. Product standards

The harmonised European Standard BS EN 13956 describes the protocol for declaration of product characteristics when tested to a wide range of European Standard test methods. In recognition of the wide range of potential applications of these products, BS EN 13956 sets few requirements as such (other than for fire performance - a roof system test - and watertightness, the latter of which is a pass/fail test). Thus whilst the Standard can be used to compare the characteristics of products, the designer must set their own requirements as relevant to the particular project conditions (see 4.4.5).

4.4.4. Generic types of membrane

Polymers suitable for roofing applications are usefully classified according to the extent of cross-linking between the polymer chains because this determines many of their characteristics and the method of forming seams.

These range from thermoplastics to elastomers, with some materials displaying features of both:

Thermoplastic

- | | |
|---------------------------------------|-------|
| a. Polyvinylchloride | PVC-p |
| b. Flexible Polyolefin | FPO |
| c. Chlorinated Polyethylene | CPE |
| d. Vinyl Ethylene Terpolymer | VET |
| e. Thermoplastic Polyolefin Elastomer | TPE |

Elastomeric

- | | |
|-------------------------------------|------|
| f. Polyisobutylene | PIB |
| g. Ethylene Propylene Diene Monomer | EPDM |

A general guide to the generic material types supplied by SPRA members is as follows;

(a) Polyvinylchloride

PVC-p is a flexible form of PVC due to the addition of high molecular weight plasticizers, which can be heat or solvent welded (depending upon the product). PVC-p-based membranes are generally not suitable for direct contact with bitumen unless a suitable weight of fleece backing is incorporated to separate the two. Generally, such membranes can be recycled back into new roofing product or for re-use in a range of other applications.

(b) Flexible polyolefin

FPO is a large family of heat-weldable polyolefin based upon polyethylene or polypropylene. Preparation of the lap prior to welding may be required. FPO-based membranes are generally suitable for direct contact with aged bitumen. Generally FPO based membranes can be recycled back into themselves or another product.

(d) Chlorinated polyethylene

Polyethylene is made flexible by chlorination and can be heat or solvent welded. Generally, CPE is compatible with bitumen.

(e) Vinyl ethylene terpolymer

VET consists of PVC made flexible by blending with Ethylene Vinyl Acetate (EVA). VET can be heat or solvent welded and is compatible with bitumen.

(f) Thermoplastic Polyolefin Elastomer

A particular group of polyolefins with the basic properties of elastomers but which can be processed as thermoplastics. They exhibit a high resistance to UV/Ozone exposure and do not absorb moisture. Laps are heat welded.

(g) Polyisobutylene

PIB incorporates carbon black to provide good physical properties. PIB products available on the UK market are generally solvent welded using tape systems. PIB is compatible with bitumen.

(h) Ethylene propylene diene monomer

EPDM is a naturally flexible material to which carbon black is added for stability. Jointing is normally carried out with tape bonding using a special primer but adhesives can also be used. EPDM is compatible with bitumen.

4.4.5. Selection criteria for single ply membrane

Technical criteria for the selection of a single ply membrane product must be related to the performance objectives, which will in turn reflect the client brief established in Section 2. These will include:

- Colour and reflectivity.
- Appearance as-built.
- Durability.
- Suitability for method of attachment.
- Suitability of accessories for termination and other details.
- Chemical compatibility.

SPRA publishes two guides:

- [S3/09 SPRA Membrane product evaluation checklist](#) is an aid to the comparison of different products against criteria of technical performance and certification criteria, product support, training and quality control.
- [SGD11/11 Single ply membranes - a guide to specification using BSEN 13956](#) takes the test methods specified in the harmonised European product standard, explains each, its relevance to system types and provides a table of recommended maximum and minimum values.

4.5. ANCILLARY COMPONENTS

4.5.1. Introduction

The design selection process should include due consideration of requirements for the following:

- Mechanical fasteners
- Lightning conductor pads
- Adhesives
- Fall-arrest anchorages
- Pre-formed details
- Rainwater outlets

4.5.2. Mechanical fasteners

[SPRA Component Quality Standard - Mechanical fasteners](#)

The correct fastener for the particular substrate will be recommended by the insulation/membrane manufacturer and/or fastener supplier. SPRA requires a minimum resistance to corrosion defined by Clause 2, UEAtc directive; "Supplementary Guide for the Assessment of

Mechanically Fastened Waterproofing” (less than 15% corrosion after 15 cycles in a Kesternich cabinet). When using dissimilar metals the risk of galvanic corrosion must also be assessed.

Table 4 below shows the minimum standards for thermal insulation pressure plates have been agreed by SPRA.

4.5.3. Adhesives

The range of adhesives for single ply membranes continues to increase. The generic types are:

- **Water-based:** compatible with a wide range of insulation materials including polystyrene. May be slower to use at low temperature and may take longer to achieve their design bond strength than solvent-based products.
- **Solvent based:** suitable tackiness achieved rapidly in normal working conditions. Where not compatible with certain cellular plastic insulation materials, taping of joints is required. These products are likely to have a high volatile organic compound (VOC) content.
- **Polyurethanes:** products available for securing insulation and membranes. Some are effective in damp (NOT wet) conditions. In recent years, polyurethane moisture curing adhesives have become very popular for bonding insulation boards, in preference to hot bitumen. Experience in the use of these newer adhesives is not as extensive; for its correct use and to achieve design resistance to wind load it is essential that the correct coverage rate is maintained, to a pattern or application method recommended by the insulation and/or membrane manufacturer (as appropriate).
- **Hot bitumen:** this should be prepared and applied in accordance with BS 8217 and the instructions of the membrane manufacturer.

The type of substrate, roof access and ambient temperature during application are crucial for the adhesive selection process.

For further information see [SGD6/08 - Quality control and use of adhesives for the attachment of vapour control layers, insulation and single ply membranes in flat roofing](#).

4.5.4. Pre-formed details

Many membranes are available with compatible factory-made three-dimensional mouldings, which may increase productivity and/or improve the protection afforded to the detail. They include internal and external corners and nosings. It is usual practice to partially or fully form the detail in the sheet membrane and then heat or solvent weld the moulding to provide added protection. Corners can also be made up on site from sheet material.

4.5.5. Membrane-lined gutters

[SPRA Component Quality Standard - Membrane-lined gutters](#)

Industrial roofing applications call for the use of prefabricated gutters linking large pitched roofs areas with coverings steel or single ply composite panels (see 4.1.5 and 4.1.6). Galvanised steel sheet with a factory-applied covering of thermoplastic single ply membrane can be sealed effectively at joints by a membrane strap and welded to rainwater outlets.

4.5.6. Rainwater outlets

Rainwater outlets suitable for single ply roofing are of three generic types:

- **Gravity - lightweight:** SPRA membrane manufacturers can supply compatible polymeric outlets designed for direct heat or solvent welding of the field membrane to the outlet flange. These are placed at membrane level, thereby speeding up installation and avoiding creation of a cold bridge. They are generally not suitable for inverted roofs and are available plain or tapered (the latter being more efficient).
- **Gravity - heavyweight:** alloy rainwater outlets are generally of tapered design. The membrane is dressed onto the tapered section, sealed, and restrained by a clamp ring secured by screws or bolts, then sealed to the outlet body with an appropriate mastic sealant. The mastic seal is generally a maintenance item which may need repair or replacement as the joints fatigue or weather.

High-efficiency refurbishment products are available which can be sealed into the bore of an existing downpipe whilst still improving upon the performance of an original plain outlet. Heavyweight, two-level outlets are suitable for public access areas, ballast and garden roofs.

- **Siphonic** - siphonic drainage uses the weight of water in the downpipe system to pull water from the roof thereby achieving very high capacity. Unless the head of water at the outlet is sufficient, the outlet will perform as a gravity outlet so it is important to design a drainage layout, which creates the necessary head of water. SPRA is working with the [Siphonic Roof Drainage Association](#) to develop specific guidance and performance standards for these products.

4.5.7. Fall-arrest anchorages

Due to the high loads exerted during a fall, traditional ‘through the roof’ anchorages for fall-arrest lines require to be tied directly back to the structure of the building. However, over the last decade, ‘top fixed’ energy absorbing anchorages have been developed that are able to dissipate such loads and, consequently, are installed directly onto the single ply membrane (warm roof) systems. Where such ‘top fixed’ anchorages are

intended for use it is imperative to obtain full test data in accordance with the recommendations of [ACR \[M\] 002:2009 Testing of roof anchors on roof systems](#).

4.5.8. Lightning conductor pads

The practice of securing lightning conductor tape with membrane flaps is no longer necessary or desirable. Compatible polymeric mouldings are available and approved for use with a wide range of membrane products. These products are attached to the membrane surfaces by solvent welding or heat welding and the conductor is secured by a clip such that the conductor is held clear of the roof surface. Attachment by self-adhesive pads has been found to be unreliable and is not recommended. Adoption of BS EN 62305 has led to increased use of finials with wire connections in place of tape. These are secured by gravity, using concrete weights set in compatible thermoplastic trays, thereby avoiding the need for welding.

4.5.9. Rooflights

There are numerous glazing materials used in rooflights, however care should be taken to ensure correct specification, particularly in relation to non fragility and fire performance; polycarbonate, GRP or glass are the options acceptable in the UK.

Kerb materials should be sufficiently mechanically and thermally robust so as to not detract from the overall performance of the building envelope.

Cellular PVC kerbs or similar low conductivity in situ details are available as alternatives to the traditional insulated metal upstands.

4.5.10. Decorative profiles

A wide range of profiles is available to replicate the appearance of metal standing seam coverings. It is also possible to use a timber batten roll and single ply membrane cover strip - or a large pre-formed profile - to replicate lead roll details. Designers are recommended to set out profiles to the same dimensional disciplines as the materials they replicate and to ensure that their effect upon drainage is checked.

4.5.11. Paving support pads

A wide variety of paving support products is available to facilitate levelling up a pedestrian surface. All such products include vertical nibs which set a consistent gap between the slabs and all products provide for vertical adjustment. Some products reduce installation time by allowing such adjustment after the slabs are laid. Since the available height and vertical adjustment limit varies with product, the design should take account of the maximum change in roof level and the tolerance in the paving thickness that must be accommodated.

4.5.12. Ballast

Many types and grades of stone are unsuitable for single ply roofing because they contain fines or sharp edges. Washed, rounded 20-40mm stone is required.

5. WORKMANSHIP

5.1. CERTIFICATION OF TRAINING

The material differences of the various single ply membranes with respect to fixing and jointing demand that the contractor is fully experienced and conversant in the handling and installation of the various products.

SPRA manufacturer members ensure that the contractors to whom they supply membrane have this relevant experience through extensive in-house training backed up by monitored post-training sitework and these processes are audited independently. Whilst some trained contractors can consequently handle several of the range of single ply materials available, the majority of general roofing contractors will have had no such experience and should not therefore handle single ply materials.

A Vocational Qualification (NVQ - England, Wales and Northern Ireland, SVQ - Scotland) is also available at level 2 ('Applied Waterproof Membranes - Single Ply Roofing'). SPRA encourages its membrane manufacturers to ensure field inspection and training staff are qualified NVQ/SVQ assessors.

SPRA recognises this qualification as evidence of specific skills in installation of single ply systems. However, it must be complemented by manufacturer training in the particular product being laid.

A two-year Specialist Apprenticeship Programme for single ply roofing.

SPRA fully supports the Construction Skills Certification Scheme (CSCS) and expects the site staff of its member companies to hold a current, appropriate card.

5.2. PROGRAMME, SEQUENCING AND INTERRUPTIONS

[SGD2/04 Safety – design considerations for reduced risk](#)

Rapid construction necessitates the sequencing of many diverse trades on the building envelope. To speed up internal fit-out, the roof is frequently completed before many potentially disruptive wet and mechanical trades have been completed. Other examples include rendering of elevations above roof level, scabbling of concrete surfaces adjacent or over the roof and installation of atria and air conditioning systems. Early consultation between the designer, membrane manufacturer and roofing contractor will assist the selection of an appropriate specification and details to avoid difficulties. For example, it may be possible to install single ply flashings before other trades commence and later to install the field membrane and weld it to the flashings. If work on a finished roof cannot be avoided, it is essential to protect the roof against loading, impact, abrasion, heat and other damage during the work.

On completion of each day's work, or whenever work is interrupted, the roof must be made secure and a 'day' joint made in order to prevent water penetration of the roof construction and/or wind damage. This procedure is facilitated if work proceeds along as narrow a working front as possible, from roof high-points and towards low-points.

5.3. STORAGE AND HANDLING OF MATERIALS

All rolls of single ply membrane and components must be placed carefully and stored horizontally on a clean, dry and flat surface above ground level. The rolls are usually wrapped individually with protective film and may be stacked on pallets 3-4 rolls high but this wrapping is only for protection in transit and handling of individual rolls. If internal storage is not possible, rolls must be protected by waterproof sheeting secured against wind load and fitted such that some air movement below is possible to avoid accumulation of condensate.

Insulation boards must be protected from weather whilst stored and during installation. The wrapping on boards as delivered is not a suitable weather protection. If internal storage is not possible, boards must be protected by waterproof sheeting secured against wind load and fitted such that some air movement below is possible to avoid accumulation of condensate.

Single ply membranes are tough and resistant to damage but delay and expense can be avoided by clear contractual terms, appropriate methods and careful planning of protection throughout the period when uncontrolled access is available to the roof. Routine good site practices should be observed at all times including care in the handling of scaffolding and other builders' plant, by avoiding the mixing of cement or mortar on the roof surface and by avoiding storing material of any kind directly on the surface.

5.4. HEALTH AND SAFETY REGULATIONS

No special scaffolding is required for single ply roofing other than that which permits ready access and complies with current safety regulations.

Facilities for hoisting should be provided and space arranged for the positioning of material on a clean, dry and level surface.

All SPRA members publish material safety data sheets giving full details of the safe use of their products and on any precautions that are necessary in accordance with the Control of Substances Hazardous to Health Regulations (COSHH).

5.5. EXISTING SUBSTRATE (*REFURBISHMENT ONLY*)

Before laying single ply membrane, ensure that the condition of the existing roof is suitable to receive the proposed roofing system. The moisture content and stability of existing materials should be checked prior to installation as it may impair the integrity of the roof. Overlays to wet roofs should be avoided.

5.6. DECK

Steel

Profiled metal decking will generally be installed by the single ply roofing contractor and should be secured against wind uplift in accordance with the deck manufacturer's requirements.

Most other forms of decking, such as concrete, timber and wood wool are typically installed by the general contractor.

Concrete

Concrete deck should be finished with a smooth, nib-free float finish. Permanent formwork is used frequently in rapid construction. If such an in-situ concrete deck is then overlaid with a waterproof membrane or vapour control layer, any excess construction water will effectively be trapped in the deck. Provided the concrete is gauged and poured correctly, this does not have significance for the strength of the concrete, nor for the single ply roof system laid over it.

However it is significant in the following situations:

- Where a bitumen sheet vapour control layer is to be applied by conventional hot pour or torch methods. In these situations, adhesion will not be achieved unless the deck is properly dry.
- Where mechanical fasteners are to be used. The advice of the membrane and/or fastener manufacturer should be sought.
- It may result in slow seepage of construction water through day joints or discontinuities in the formwork.

Drying process

An indication of how slow the drying out process is can be gained from BS 8203, which uses the rule of thumb that a screed will dry at approximately 1mm per day (from one face) in well ventilated conditions with reduced drying rates as the process continues, such that a 50mm screed will take some two months. The equivalent times for structural slabs is expected to be much slower and may be nearer one year for a 150mm slab to dry.

Therefore, rapid construction with in-situ concrete on permanent formwork should be avoided, the preferred options being use of perforated formwork or (as recommended in BS 6229) by temporary facilities above the roof to enable full drying out of the deck.

Timber

Timber decking should be installed with no gaps at butt joints and securely fastened to joists with ring shank nails or screws.

Plywood

Plywood decking should be installed at a moisture content of 14 -18% and laid with a gap between boards of 1mm per metre of panel size. Boards should not be laid at a moisture content in excess of 18%. Panels should be fastened securely to joists with ring shank nails or screws at 300mm centres.

Wood Wool

Wood wool slabs should be installed in accordance with the manufacturer's requirement.

5.7. VAPOUR CONTROL LAYER *(warm roofs only)*

The specified vapour control layer (VCL) should be adequately sealed at side and end laps. On metal decks with polyethylene VCL, bitumastic tape should be used and all joints should be supported during the sealing process.

The VCL should be turned up to all vertical surfaces by the thickness of the insulation. Where applicable, sufficient additional material should be retained at the perimeter to enable it to be sealed to a suitable surface of the perimeter to form an air and moisture vapour seal. Where possible, all penetrations of the vapour control layer should be sealed as appropriate to the use of the system.

5.8. THERMAL INSULATION

Before installing thermal insulation, ensure that the surfaces to be covered are firmly fixed, clean, dry, smooth and free from frost, contaminants, voids and protrusions.

All preliminary work including formation of upstands, kerbs box gutters, sumps, grooves, chases, expansion joints, etc. and fixing of battens, fillets, anchoring plugs/ strips, etc. is complete and satisfactory.

The supporting deck should be clean, dry, without large projections, steps or gaps and should be graded to provide the correct falls to rainwater outlets.

The roof insulation boards should be laid break-bonded (with the exception of tapered boards) and installed strictly in accordance with the manufacturer's recommendations.

Where appropriate the manufacturer should be consulted regarding the spanning, cantilever capability and installation technique of the insulation board.

Where membranes are to be fully adhered to the face of the insulation board check that:

- The boards are to a level consistent with building and product tolerances. This will improve appearance and reduce voids under the membrane that could reduce resistance to wind load.

- The adhesive and insulation are compatible.
- Board joints have been taped (if necessary).
- Board facings are designed to withstand the design wind load.

5.8.1. Mechanically fastened

SPRA insulation manufacturer members will provide minimum requirements for fastener quantity and layout.

Fasteners used to secure the insulation should be placed within the area of the individual board and not at joints. Fasteners required to meet the design loading conditions should be evenly distributed over the full area of the board in the pattern proscribed by the manufacturer. Each fastener should incorporate a washer, having a minimum surface area as per 4.5.2 Table 4 and be placed so that it is in contact with one board only.

When using mechanically fastened insulation board beneath a fully adhered single ply membrane the insulation must have sufficient fasteners to resist wind uplift. The membrane manufacturer will generally provide this information.

When using mechanically fastened insulation below a mechanically fastened waterproof membrane, the recommendations of the insulation manufacturer should be followed and the insulation fastenings should not generally be considered as contributing to the securing of the waterproofing membrane.

5.8.2. Adhesion

[SGD6/08 - Quality control and use of adhesives for the attachment of vapour control layers, insulation and single ply membranes in flat roofing](#)

Thermal insulation boards should be adhered directly to the substrate/vapour control layer using a synthetic bonding adhesive or bitumen bonding compound. Different products are suited to each insulation and membrane product.

Bonding the larger 1200 x 2400mm boards should be avoided. Always establish the application rate required from the adhesive supplier, including the extra required in roof perimeters. One rate will not suit all roofs because the exposure to wind uplift is unique to each building. Check who is responsible for the job-specific application rate and ensure it is achieved.

On metal decks lay boards with long edges at 90° to the troughs with end joints fully supported on crowns.

Once boards are laid, ensure that they are in good condition, well fitting and with no springing, flexing or rocking.

5.9. WATERPROOF MEMBRANE

The three principal methods for securing the waterproofing layer to the substrate are:

- Mechanical attachment.
- Adhesion.
- Ballast.

The sheets of waterproofing membrane should be rolled out (over the separation layer if applicable) onto the substrate and where required by the manufacturer, allowed to relax.

The sheets should be inspected for defects prior to being correctly aligned (allowing for the correct overlap with adjacent sheets) before attachment to the substrate.

When the waterproof membrane has been installed, it is important to seal the laps as quickly as possible. There are rarely situations where delay is advantageous.

Single ply membranes can be laid with the line of fall or across it; the orientation of seams in relation to the fall is also of no significance for performance. Rather, setting out should be planned taking into consideration the following:

- Point of access.
- Temporary drainage.
- Formation of effective day joints.
- Sequencing of other trades.
- Minimising waste.

Close adherence to the specification is critical, particularly in the case of mechanically/partially attached systems where precise calculations will have been carried out to ensure the system is secured against wind uplift.

5.9.1. Mechanical fastening

There are three commonly employed methods of mechanically fastening single ply membranes: seam/spot fastening, linear bar fastening and disc fastening (see 3.15.2). The membrane manufacturer will advise on the most suitable method for their system or the application.

Screw fasteners should be properly driven home at the appropriate torque. Care must be taken so as not to over tighten screws as this may reduce resistance to pull-out or cause subsequent failure of the fastener. On profiled metal decks, fasteners should be driven into the deck crowns only.

In-seam fastening

The membrane is laid perpendicular to the deck direction (if metal) and then mechanically fastened in the sheet overlap area. The washers/pressure plates should be positioned at the required centres and the fasteners installed through the washers (and insulation where applicable) and secured into the deck. When correctly installed, the washers should be in a line, resist rotation

by hand and be set inside the membrane lap rather than overlapping an edge. Weathering is normally achieved by sealing the laps over the top of the fastenings. Fastenings at intermediate locations are weathered in the same manner as linear bar fastenings.

Linear (bar) fastening

The membrane is laid perpendicular to the fixing direction and all joints are welded. The linear bars and fasteners are then installed at the manufacturer's specified intervals with additional fixings at perimeters and penetrations. Bars are generally laid perpendicular to the longitudinal axis of profiled metal decks in order to distribute wind load across the deck crowns. Linear bars are then weathered as recommended by the membrane manufacturer (normally by covering with detailing strips of the main roof membrane).

Disc fastening

Discs are set out at a rate per unit area related to design wind load and the fastener transfers this load to the deck. Thus the number may vary across the roof field. Adhesive is applied to the face of the discs and the field membrane is then rolled out over them. Seams are welded as a separate operation.

Where the insulation is mechanically fastened, the recommendations of the insulation manufacturer should be followed and the insulation fastenings should not generally be considered as contributing to the securing of the waterproofing membrane. Likewise, unless specifically permitted by the membrane manufacturer, membrane fasteners should not be considered as contributing to the attachment of any mechanically-fixed insulation in the roof system.

The installed membrane must be adequately protected against damage during completion of the roofing works and from following trades. Point loading should be avoided.

5.9.2. Adhesion

[SGD6/08 - Quality control and use of adhesives for the attachment of vapour control layers, insulation and single ply membranes in flat roofing](#)

Procedures may vary according to whether the membrane is plain or fleece-backed.

Care should be taken to apply the waterproofing sheet in a manner that minimises voids and wrinkles and ensures that the entire sheet is fully adhered. Puddles or blobs of adhesive should be avoided as these may lead to punctures or poor adhesion, or collapsed insulation. Entrapped air should also be minimised to avoid later punctures. On systems that require the lap to be sealed by an alternative method (e.g. welding or with an alternative adhesive), measures should be taken to avoid spillage of adhesive onto the lap joint area. All membrane perimeters should be mechanically fastened by a method

defined by the membrane manufacturer.

Where a contact adhesive is used, the sheets of membrane should be rolled out and positioned with correct overlaps. Each sheet should be folded back in half and the adhesive should be applied to the substrate and to the back of the membrane in accordance with the manufacturer's recommendations, before being allowed to partially dry as required. Drying times will vary, according to the weather conditions. The membrane is then unfolded onto the prepared substrate. This operation should then be repeated on the other half of the sheet, positioning the membrane accurately, as the bond is difficult to break once contact between the two surfaces has been affected. Once the sheet has been installed, a water filled roller (a hand roller for vertical or slopes) should be used to ensure intimate adhesion between the two adhered surfaces.

Full bonding using a proprietary adhesive should be achieved by following the recommendations of the manufacturer (paying close attention to the Health & Safety precautions). Partial bonding, whether by use of strips of adhesive or some other pattern must be strictly in accordance with the membrane manufacturer's instructions.

Where the membrane is to be laid into wet adhesive, a coat of adhesive or special primer is applied to the substrate, which is allowed to dry thoroughly. The sheet should be positioned with correct overlaps and rolled back from either end to the centre of the roll. The bonding adhesive is then applied to the substrate with a brush, roller, trowel or spray and the membrane is laid into the wet adhesive. With fleece-backed products, two coats of adhesive may be required by the membrane manufacturer, each applied to the substrate, not the fleece.

The same process should be repeated for the second half of the roll. Pressure should then be applied (with a water filled roller, for example) to ensure maximum contact with the adhesive.

Where the membrane is bonded in an area where there is a change of direction (e.g. where it meets perimeter upstands) ensure that the membrane is mechanically secured to prevent bridging.

Overlaps should be jointed as recommended by the membrane manufacturer.

5.9.3. Ballast

Ballast may be used to restrain the components of both warm roof and inverted roof systems.

Warm roof application

The sequence of installation is as follows:

- Single ply membrane is laid loose over the insulation in accordance with the membrane manufacturer's recommendations.

- A compatible polymeric protection layer is laid loose over the single ply membrane. This layer serves to protect the waterproofing from abrasion.
- Gauge boards should be laid to set a depth for the ballast.
- Ballast is then applied as evenly as possible, to avoid large accumulations of material.
- Ballast is levelled off carefully with a straight edge.

For Polyisocyanurate insulation there is an [Information Document ID3/2009](#) published by the British Rigid Urethane Foam Manufacturers Association.

Inverted warm roof application

The membrane should be applied over any specified protection layer and the laps sealed in the manner specified. Any mechanical or adhesive restraint at perimeters and details should be installed as recommended.

When the membrane manufacturer has supplied two different membranes of different formulation for exposed and covered applications on the same roof area, the specification should be followed carefully, paying special attention to the interface detailing.

A separation layer may be specified over the waterproof membrane. Insulation is then laid loose above the waterproofing membrane/separation layer, ensuring that joints are tight and rebates engaged wherever practical. Care should be taken to ensure that the separation layer is applied in all areas where an interface may occur between the insulation and the waterproofing membrane. This is normally achieved by turning the separation layer up at all perimeter edges of the insulation boards and at all roof penetrations.

A suitable non-woven filtration layer should be laid over the insulation with side and head laps as specified and extended vertically at upstands and details such that ballast is not in direct contact with the waterproof membrane. Where a water control membrane is specified, this must be fully supported, lapped in accordance with manufacturer's instructions and dressed at details so as to ensure maximum movement of water towards the rainwater outlets and not through the insulation.

The roof should always be ballasted, with the specified aggregate or paving. The ballasting should be sufficient to resist wind uplift and flotation and should be applied as soon as practicable to prevent wind damage to the single ply system, but after the checking of all seam joints and/or integrity testing.

Gravel guards should be in place on all roof outlets before stone ballast is laid.

Gauge boards should be placed to match the specified depth and ballast should be spread between them. The correct depth of ballast should be levelled off with a straight edge and the gauge boards moved on. Paving slabs should be set out to minimise cutting.

Slabs should be laid from the roof access point to minimise trafficking on the unprotected membrane. Slabs should be laid on the filter layer (or on any specified additional protection layer). They should not be tightly butted to the upstand because allowance must be made for thermal movement. This can be achieved by either a 150mm margin of washed and rounded stone or by a proprietary compressible margin of bonded granulated rubber. If paving support pads are used, care should be taken to avoid damaging vertical nibs and manufacturers' instructions should be followed in respect of the maximum vertical adjustment or stacking of supports.

Care should be taken not to exceed the limitations on roof loading.

If there is to be any delay in applying the finishing ballast, then a temporary ballast should be applied (e.g. sand or gravel, wrapped in bags, to prevent damage to the system) being strategically placed across the finished roofing. It may also be a requirement to attach the insulation by either bonding or mechanically fixing. Refer to the insulation manufacturer for guidance.

5.10. TEMPORARY PROTECTION OF ROOF SYSTEM

Full temporary protection of the roofing is essential if following trades are to use the finished roof as a working platform or access walkway. The responsibility for ensuring this must be agreed between relevant parties during the course of the building operations.

In general, no building work should be carried out from a completed roof. Paint, cementitious materials, plaster and solvents should not be allowed to come into contact with the completed roof surfacing.

The complete roof should NOT be used as a working platform.

5.11. INSPECTION

During the course of construction, routine interim and final inspections should be carried out in accordance with specific manufacturer's instructions. This is the primary responsibility of the roofing contractor. However, the client and/or main contractor (if any) should be aware that the SPRA Bylaws require that manufacturers also make a recorded inspection before a guarantee is issued and may additionally make interim inspections.

5.12. TESTING FOR INTEGRITY

[SGD5/07- Non-destructive testing of single ply membranes](#)

The roofing contractor should carry out mechanical integrity testing of jointed seams on a daily basis using a probe, or where doubt persists, with a random peel test. Additional random mechanical checking of joints will be carried out by the manufacturer during inspections. Prior to hand-over, all seams should be checked visually (and

with a probe if recommended by the manufacturer) and made good as necessary.

If following trades are to use the finished roof covering as a working platform or for access, it is recommended that integrity testing be carried out and the results notified to the main contractor (as appropriate) prior to any other trades having access. It may then be necessary to re-test affected areas after the other works are complete.

Appropriate methods of test vary with the roof type and the objective.

Low voltage electrical resistance (pulse) testing is suitable for proving waterproofing integrity or for locating known water ingress. It is not suitable for EPDM and other electrically conductive membranes or for electrically insulating decks and it requires a wet roof surface.

Electrical capacitance testing is suitable for locating areas of water ingress and for assessment of existing roofs for water entrapment. It can be used to give an approximate location of points of ingress but tends not to be as accurate as resistance testing. It is also not suitable for EPDM and other electrically conductive membranes or for electrically insulating decks and it requires a dry roof surface.

Vacuum testing is suitable for testing the integrity of small areas of membrane such as seams. It is slow, cumbersome, and unlikely ever to be economically feasible for the roof field as a whole.

Thermal imaging is most suitable for strategic assessment of existing structures for thermal integrity and moisture ingress into insulation or heavyweight decks. It is not generally suitable for proving the integrity of a waterproof membrane. It is generally necessary to test at night when thermal conditions are stable. A heated building interior may be required to create the necessary temperature difference across the roof cross-section.

Flood testing is not recommended unless the nature of the roof or building function demands this direct method. It should never be chosen unless a thorough assessment of its implications has been made.

- The weight of water stored must not exceed the structural limits of the construction.
- The effect of water ingress and water entrapment within the roof system must be considered.
- Rainwater outlets must not be covered in case rain occurs during testing and weight limits are exceeded. Bunds should be formed around outlets and to define the area of test.

6. MAINTENANCE

Routine maintenance of the membrane is not normally required but regular inspection of the roof should be carried out twice per year preferably in early spring and late autumn. The purpose of this inspection is to:

- Check for damage.
- Ensure rainwater outlets are not obstructed.
- Check that materials from other trades have not been left on roof.
- Check lightning and fall arrest equipment.

If ponding causes accumulation of silt or algae on exposed membranes this can be removed by brushing when wet with a soft bristle brush and removed by water spray. Proprietary fungicides or cleaners are not necessary and may not be compatible with the waterproofing; they should not be used.

It is recommended that a standard format roof plan, marked with coordinates, be used to record the findings of a planned inspection. This will avoid confusion with instructions to contractors and provide an ongoing record of roof performance, which can be compared year-on-year.

Timber roof decking should be set aside to allow removal of debris that could otherwise obstruct drainage. This is particularly important on buildings near trees.

7. ROOF REFURBISHMENT

7.1. INTRODUCTION

Because it is lightweight, easy to detail and available in a range of attachment options, single ply technology is well suited to roof refurbishment. The same evaluation process in respect of performance criteria (Section 2) should be followed as for new construction, but with the constraints imposed by the existing construction fully understood.

If refurbishment is required due to failure of the existing, the cause should be fully investigated. For example, cracking of an old bituminous system due to building movement may necessitate revised detailing.

7.2. REMOVAL OR OVERLAY OF EXISTING SYSTEM

A major decision concerns whether to remove existing components or to overlay them.

Overlay has the following advantages:

- The interior is at minimal risk of water ingress throughout the works.
- Waste removal and disposal cost is minimised.
- Contract period can be minimised.

Overlay also has the following disadvantages:

- Roof loading may exceed the capacity of the structure.
- Any entrapped moisture due to past water ingress must be dissipated effectively.
- Details may be compromised by increased finished roof height.
- Options for improving drainage will be restricted.
- Options for attachment of the new system may be restricted.

Removal of the existing system provides maximum scope for correction of deficiencies in the existing design and for thermal upgrading. It also widens the choice of attachment methods.

7.3. CHANGE OF USE

Refurbishment dictated by change of use will require special consideration of the following:

- Imposed loads may change, due to roof-mounted plant or access arrangements.
- Mandatory resistance to external fire may change.
- Internal relative humidity may change, requiring modified thermal design.
- Aesthetic considerations may restrict choice, for example with rainwater goods.

7.4. EXISTING DECK

A wide range of deck materials may be encountered on existing buildings. In addition to the above, these may include timber boarding, aerated concrete and soft boards.

On no account should strawboard, softboard or chipboard be considered as suitable materials for mechanical attachment. It is likely that their replacement will be required in any case, due to deflection and/or softening.

Due to potential deterioration from moisture, and the difficulties of determining the nature of an existing deck, advice should be sought from membrane and fastener manufacturers.

Where mechanical attachment is proposed, the fastener manufacturer must undertake pullout tests to establish the level and consistency of restraint provided by the existing deck (at the crowns if metal deck).

If the existing drainage layout is poor and ponding widespread, retention of an existing deck will restrict the range of design options; only a warm roof system with tapered insulation will be suitable.

7.5. INSULATION

When upgrading thermal insulation or installing a tapered insulation scheme, consideration should be given to the effect upon finished roof height especially at points furthest from rainwater outlets. It may be necessary to raise upstand heights to achieve a minimum 150mm height above finished waterproofing level.

8. REFERENCES

Note: the following key references appear in the text of the Design Guide. All are subject to change and their accuracy is not guaranteed.

8.1. REGULATIONS

The Building Regulations Approved Documents can be found and downloaded at www.planningportal.gov.uk

The Building Regulations Approved Document B - Fire safety

The Building Regulations Approved Documents F - Ventilation

The Building Regulations Approved Document Part H - Drainage and waste disposal

The Building Regulations Approved Document Part L (L1A, L1B, L2A & L2B) - Conservation of fuel and power in dwellings

The Building Regulations Approved Document Part M - Access to and Use of Buildings

The Scottish Building Standards Agency – Technical Handbooks Section 6 - Energy

The Construction Design and Management Regulations (CDM)

Fire Precautions (Workplace) Regulations

Control of Substances Hazardous to Health Regulations (COSHH)

Work at Height Regulations

8.2. NORMATIVE REFERENCES

BS 476 Part 3 External fire exposure roof test

BS 3837-1: Expanded polystyrene boards. Boards and blocks manufactured from expandable beads. Requirements and test methods

BS 4841-4: Rigid polyurethane (PUR) and polyisocyanurate (PIR) foam for building end-use applications Specification for laminated board (roofboards) with auto-adhesively or separately bonded facings for use as roofboard thermal insulation under non-bituminous single ply membranes

BS EN 1995-1-1:2004+A1: Eurocode 5. Design of timber structures. General. Common rules and rules for buildings.

BS EN 300: Oriented strand boards (OSB). Definitions, classification and specifications

BS EN 485-2: Aluminium and aluminium alloys. Sheet, strip and plate. Mechanical properties

BS EN 636-2: Plywood. Specifications. Requirements for plywood for use in humid conditions.

BS EN 636-3: Plywood. Specifications. Requirements for plywood for use in exterior conditions.

BS EN ISO 6946: Building components and building elements. Thermal resistance and thermal transmittance. Calculation method.

BS EN 795: Protection against falls from a height. Anchor devices. Requirements and testing

BS EN 1396: Aluminium and aluminium alloys. Coil coated sheet and strip for general applications. Specifications

BS EN 10147: Continuously hot-dip zinc coated structural steels strip and sheet. Technical delivery conditions

BS EN 13162: Thermal insulation products for buildings. Factory made mineral wool (MW) products. Specification

BS EN 13163: Thermal insulation products for buildings. Factory made products of expanded polystyrene. Specification

BS EN 13164: Thermal insulation products for buildings. Factory made products of extruded polystyrene foam (XPS). Specification

BS EN 13165: Thermal insulation products for buildings. Factory made rigid polyurethane foam (PUR) products. Specification

BS EN 13166: Thermal insulation products for buildings. Factory made products of phenolic foam (PF). Specification

BS EN 13167: Thermal insulation products for buildings. Factory made cellular glass (CG) products. Specification

BS EN 13168: Thermal insulation products for buildings. Factory made wood wool (WW) products. Specification

BS EN 13169: Thermal insulation products for buildings. Factory made products of expanded perlite (EPB). Specification

BS EN 13501-2: Fire classification of construction products and building elements. Classification using data from fire resistance tests, excluding ventilation services

BS EN 13956: Flexible sheets for waterproofing - Plastic and rubber sheets for roof waterproofing - Definitions and characteristics

8.3. INFORMATIVE REFERENCES

BS 5250: Code of practice for control of condensation in buildings

BS 6229: Code of practice for flat roofs with continuous supported Coverings

BS EN 1991-1-1: Eurocode 1. Actions on structures. General actions. Densities, self-weight, imposed loads for buildings.

BS EN 1991-1-4 + A1. Eurocode 1. Actions on structures. General actions. Wind actions

NA to BS EN 1991-1-4 + A1. UK National Annex to Eurocode 1. Actions on structures. General actions. Wind actions

BS EN 1991-1-7: Eurocode 1. Actions on structures. General actions. Accidental actions.

BS EN 62305: Protection against lightning.

BS 8217: Reinforced bitumen membranes for roofing. Code of practice.

BS EN 12056 - 3: Gravity drainage Systems inside buildings. Roof drainage, layout and calculation.

8.4. OTHER REFERENCES

ANSI/SPRI/FM 4435/ES-1 'Wind Design Standard for Edge Systems Used with Low Slope Roofing Systems'

British Flat Roofing Council (BFRC)/CIRIA 'Flat Roofing - Design and Good Practice' 1993

BFRC & Napier University 'The Assessment of Lifespan Characteristics and As-built Performance of Flat Roofing Systems: A summary and recommendations for construction professionals' 1994

British Urethane Foam Manufacturers Association Information document ID/1/2009, published by BRUFMA tel. 0161 236 7575 www.brufma.co.uk

Building Research Establishment Digest No. 346: 1989 Assessment of Wind Loads

Building Research Establishment BR262 Thermal insulation: avoiding risks 2002 edition

Chartered Institute of Building Services Engineers Guide: Volume A – Design Data

CITB Construction Skills – Training resource pack for single ply roofing.

FM Approvals standard 4470 Approvals standard for Single Ply Roof Assemblies for use in Class 1 or Non Combustible Roof Deck Construction. www.roofnav.com

FM Global Loss Prevention Data Sheets (www.fmglobaldatasheets.com and www.roofnav.com)

Green Roof Organisation (GRO) www.livingroofs.org

- GRO Guidelines 2010
- Green Roof Code of Practice 2011

National Association of Rooflight Manufactures (NARM) www.narm.org.uk

Siphonic Roof Drainage Association www.siphonic-roof-drainage.co.uk

- An introduction to siphonic drainage
- The Siphonic Guide
- Model specification for siphonic drainage

SPRA

Documents available from www.spra.co.uk – Technical guidance documents

- [SGD2/04 – Safety-design considerations for reduced risk](#)
- [SGD4/06 – Use of Sealants](#)
- [SGD5/07 – Non-destructive Testing of Single Ply Membranes](#)
- [SGD6/08 – Quality control and use of adhesives for the attachment of vapour control layers, insulation and single ply membranes in flat roofing](#)
- [SGD7/10 – Acoustic control within buildings](#)
- [SGD8/13 – Falls and drainage for single ply roofs](#)
- [SGD9/11 – Wind load design requirements](#)

Guides and checklists

- [S3/05 – SPRA Membrane product evaluation checklist](#)
- [S4/08 – Guarantees for materials and workmanship](#)

Component Quality Standards

- [Insulation – Expanded polystyrene](#)
- [Insulation – Extruded polystyrene](#)
- [Insulation – Mineral wool insulation](#)
- [Insulation – Rigid urethane insulation](#)
- [Insulation – Expanded polystyrene for inverted roofs](#)
- [Mechanical fasteners](#)
- [Membrane – lined gutters](#)
- [Rooflights](#)

UEAtc directive; 'Supplementary Guide for the Assessment of Mechanically Fastened Waterproofing'

SPRA



We've Got It Covered

Single Ply Roofing Association

Roofing House
31 Worship Street
London EC2A 2DY

Tel: 0115 914 4445

Fax: 0115 974 9827

Email: enquiries@spra.co.uk

www.spra.co.uk