



# Roof Systems Manual





## Contents

<p><b>A good roof – the most important facade</b> 5</p> <p><b>A roof is of primary importance</b> 6</p> <p style="padding-left: 20px;">Roof system regulations and guidelines 6</p> <p style="padding-left: 20px;">CE marking of construction products 6</p> <p style="padding-left: 20px;">Product and contracting certificate 6</p> <p><b>Low Pitched Roofs</b></p> <p><b>Design of low pitched roofs</b></p> <p style="padding-left: 20px;">Life span of a roof 7</p> <p style="padding-left: 20px;">Roof structures 7</p> <p style="padding-left: 40px;">Air barrier 7</p> <p style="padding-left: 40px;">Vapour barrier 7</p> <p style="padding-left: 40px;">Recommended vapour barriers 7</p> <p style="padding-left: 40px;">Vapour barrier to be specified according to prevailing conditions 7</p> <p style="padding-left: 20px;">Ventilated roof structures 8</p> <p style="padding-left: 20px;">Ventilated voidless structures 8</p> <p style="padding-left: 20px;">Unventilated roof structures 8</p> <p style="padding-left: 40px;">Pressurised roof construction 8</p> <p style="padding-left: 40px;">Warm roofs 8</p> <p style="padding-left: 20px;">Inverted roofs 8</p>	<p style="padding-left: 20px;">Roof decking 9</p> <p style="padding-left: 20px;">Timber substructure 9</p> <p style="padding-left: 40px;">Board decking 9</p> <p style="padding-left: 40px;">Timber panel decking 9</p> <p style="padding-left: 20px;">Concrete decks 9</p> <p style="padding-left: 20px;">Insulation slab substrate 9</p> <p style="padding-left: 40px;">Mineral wool 10</p> <p style="padding-left: 40px;">Plastic insulation slabs 10</p> <p style="padding-left: 40px;">Cellular glass 10</p> <p><b>Roofing systems</b></p> <p style="padding-left: 20px;">Bitumen membranes 11</p> <p style="padding-left: 20px;">Two-ply roofing 11</p> <p style="padding-left: 20px;">Single-ply roofing 11</p> <p style="padding-left: 20px;">Rating of bitumen membranes 11</p> <p style="padding-left: 20px;">Use classification of bitumen membranes 11</p> <p style="padding-left: 20px;">Fire rating 14</p> <p style="padding-left: 40px;">The Finnish Roofing Association's recommendations for constructing fire breaks 14</p> <p style="padding-left: 20px;">Properties of bitumen adhesives 14</p> <p style="padding-left: 20px;">Other membranes 14</p> <p><b>Fixing of membrane roofing</b></p> <p style="padding-left: 20px;">General 15</p> <p style="padding-left: 20px;">Bonding with bitumen 15</p> <p style="padding-left: 20px;">Mechanical fastening 15</p> <p style="padding-left: 40px;">Fastening to timber decking 15</p> <p style="padding-left: 40px;">Fastening to concrete decking 15</p> <p style="padding-left: 40px;">Fastening to insulation slabs 15</p>	<p><b>Details</b></p> <p style="padding-left: 20px;">Penetrations 16</p> <p style="padding-left: 40px;">Joining penetrations to roofing 16</p> <p style="padding-left: 20px;">Roof drains 16</p> <p style="padding-left: 20px;">Rainwater scupper 16</p> <p style="padding-left: 20px;">Lead-through collars 16</p> <p style="padding-left: 20px;">Suction ventilators 16</p> <p style="padding-left: 20px;">Roof bollards 17</p> <p style="padding-left: 20px;">Upturns 17</p> <p style="padding-left: 20px;">Eaves 17</p> <p style="padding-left: 20px;">Valleys 17</p> <p style="padding-left: 20px;">Movement joints 17</p> <p><b>Trafficked areas, outdoor decks and terraces</b></p> <p style="padding-left: 20px;">Thermally insulated structures 18</p> <p style="padding-left: 20px;">Inverted roof structure 18</p> <p style="padding-left: 40px;">Upturns in inverted structures 18</p> <p style="padding-left: 40px;">Roof drains in inverted structures 19</p> <p style="padding-left: 40px;">Other penetrations through an inverted structure 19</p> <p style="padding-left: 20px;">Enclosed structure 19</p> <p style="padding-left: 20px;">Cold decks 19</p> <p style="padding-left: 20px;">Green Roofs 19</p> <p style="padding-left: 20px;">Bridges 19</p>
---	--	--

<b>Renovation of low pitched roofs</b>		<b>Bitumen roofings on steep roofs</b>		Flashings (upturns)	54
Surveying the condition of a roof	20	General	41	Verge trim	54
Refurbishment plan	20	Decking	41	Ridge capping (ridge and hips)	54
Conventional roofing repair options	21	Ventilation	42	Installation of roof access hatch	54
Reroofing over the existing membrane	21	Fixing	42	Weatherproofing of penetrations	54
Removal of old roofing	21	Eaves and verges	42	Chimney flashing	54
Adjusting the roof fall	21	Penetrations and wall upturns	42	<b>Long strip roofing with welted seams</b>	
The repair of a sheetmetal roof with bitumen membranes	21	<b>Bitumen roofing shingles</b>		General	55
<b>Construction of low pitched roofs</b>		General	43	Roof deck	55
Hot work regulations	22	Roof pitches and underlays	43	Sheetmetal strips, seams and fixing.	55
Hot work permit	22	Eaves and verges	43	Curb gutters and penetrations	55
Hot Work Permission / Checklist for Hot Work	22	Installation of roofing shingles	43	Upturns	55
Hot work supervision plan	22	Valleys	43	Quality requirements: Pressed panels and corrugated roofings	56
Safety at work	22	Ridge and hips	43	Quality requirements of long strip sheetmetal roofing	57
Protection against falling	22	Penetration weatherproofing and other upturns	43	<b>Detail Drawings (Sheetmetal roofs)</b>	<b>58</b>
Access routes	22	<b>Bitumen roofing with upstand sidelaps</b>		<b>Tiled roofs</b>	
Canopies	22	General	44	Fired clay tile roofing	63
General tidiness and order	23	Roof pitches and underlays	44	Concrete tile roofing	63
Equipment	23	Eaves and verges	44	Design	63
Propane equipment	23	Traditional bitumen roofing with upstand sidelaps	44	Roof pitch	63
Propane hand torches	23	Valleys	44	Supporting structure	63
Bitumen boilers	23	Ridge	44	Underlay for concrete tile roofing	63
Hot air guns	23	Weatherproofing of penetrations	44	Underlay for clay tile roofing	63
Working conditions and protection during construction	23	“Modern” upturn sidelap roofing	45	Loadbearing structure	64
Installation of vapour barrier	24	<b>Continuous roofing systems</b>		Execution	64
Installation of insulation	24	General	46	Installation of tiled roof	64
<b>Installing bitumen membranes</b>		Self-adhesive bitumen membranes	46	Installing the underlay	64
Fixing methods	25	Gluable bitumen membranes	46	Installation of tile battens	64
Bonding with adhesive	25	Cold bonding systems	46	Installation of roof tiles	64
Torching	25	Hot bonding systems	46	Nailing	64
Fixing the cap sheet	26	Torch-on bitumen membranes	46	Details	64
Mechanical fixing	26	<b>Quality requirements of bitumen roofing</b>	<b>46</b>	Eave	64
Overlaps	26	<b>Detail Drawings (Bitumen roofing system)</b>	<b>47</b>	Verge	65
<b>Installing PVC roofing</b>	<b>27</b>	<b>Sheetmetal roofs</b>		Valley	65
<b>Quality requirements of contracted work</b>	<b>28</b>	General	50	Hip	65
<b>Detail Drawings (Low pitch roofs)</b>	<b>30</b>	Design	50	Ridge	65
<b>High pitched roof</b>		General	50	Penetrations and upturns at wall abutments	65
Choosing your roofing	37	Roof pitches	50	Roof hatch	66
Roof structures	37	Roof deck	50	Roof safety fittings	66
Roof ventilation	37	Ventilation	51	Quality requirements	66
Roof pitches	37	Details	51	<b>Detail Drawings (Tiled roofs)</b>	<b>67</b>
Air and vapour barrier	38	Coatings	51	<b>Contract procedure</b>	<b>70</b>
Underlays	38	<b>Profiled sheetmetal roofs</b>		<b>Maintenance</b>	<b>73</b>
The classification of underlays	38	General	52	<b>The Finnish Roofing Association</b>	<b>74</b>
Fixings	40	Substructure	52	<b>Roofing and waterproofing regulations and guidelines</b>	<b>75</b>
Penetrations and wall joints	40	Fixings	52	<b>The members of the Finnish Roofing Association</b>	<b>76</b>
Rainwater systems	40	Implementation	52		
Roof safety products	40	Dimensions	52		
Safety at work	40	Installing the underlay	52		
Maintenance	40	Installation of purlins	53		
		Installation of barge boards	53		
		Valley	53		
		Installation of profiled sheetmetal roofing	53		







## **A good roof – the most important facade**

Buildings constitute a major part of the Finnish national wealth. We simply cannot afford its premature decay.

A healthy building can only exist under a well functioning roof. A correctly designed and well executed roof system means the preservation of our national wealth and natural resources, and implies appreciation of sound professional construction.

The decisions made at three separate stages influence the life span of a roof: during its design, during the actual execution of the work and during its service life.

At the design stage we set a goal for the life span of a roof and this has implications for the design of its structural system and details as well as for the choice of materials.

In the execution of the actual work, the roof is constructed according to design specifications and applying the good building practices and generally approved installation methods of the roofing industry.

Correct and sufficiently frequent maintenance during the service life plays a critical role in the durability and functioning of a roofing system.

The projected life span of a roof can only be realised when all the stages of the roof's life cycle are executed correctly and in a predetermined manner.

The Roof Systems Manual is based on the long standing experience and expertise of roofing professionals and provides the tools to execute and perform these stages correctly.

This applies not only to roofs. All other waterproofing must be designed and executed according to the above principles. This is the only way to ensure that the whole design life span of the building can be attained in the desired manner.

### **The Roofing Systems Manual now covers more ground than ever**

The Finnish Roofing Association has for decades done work towards better roofs, and the Roofing Systems Manual has been an important tool in implementing this goal.

This manual presents the association members' shared view of how to attain a sound and well functioning roof or other waterproofing system.

The Roofing Systems Manual is based on the experience and expertise of roofing contractors and material suppliers.

Thanks to the progress made in the association's activities and development of the member base, the manual's contents cover a wider range than ever before. It is divided into two parts according to roof shape, Low Pitched Roofs and High Pitched Roofs, of which the latter is sub-divided into three main sections, depending on the roofing material: bitumen roofing systems, metal roofs and tiled roofs. The section Low Pitched Roofs also includes various structural solutions relating to waterproofing in different parts of a building.

### **The Roofing Systems Manual is a tool for good roofing**

Apart from being an expression of expert opinion, this publication is a useful tool for all who are involved in roof construction or repairs – for professional contractors and clients alike.

The Finnish Roofing Association's objective in publishing this manual is to encourage the parties involved in construction to design, execute, buy and demand good and well functioning roofs and other waterproofing systems that will retain their integrity for their design life.

The Roofing Systems Manual is updated as required and the latest version is available on the website of the Finnish Roofing Association at [www.kattoliitto.fi](http://www.kattoliitto.fi) including a list of dated amendments.

Finnish Roofing Association  
Mikko Ahtola  
CEO





## A roof is of primary importance

The roof is a system that separates the building's top floor from the outdoor environment. It consists of functional parts, which have to work together:

- supporting structure
- air barrier
- vapour barrier
- insulation
- ventilated space if appropriate
- decking for roofing
- actual roofing
- water drainage
- penetrations
- other auxiliary roof structures

### Roof system regulations and guidelines

Structural design and the use of products in construction are regulated by EU building product directives, harmonised product standards, national building codes, e.g. The National Building Code of Finland and voluntary guidelines such as the Roof Systems Manual, the RT construction file, water and moisture-proofing code

of practice (RIL 107), RYL 2000 on the quality requirements in the construction industry as well as the product and contracting certificates given by VTT Technical Research Centre of Finland, all of which illustrate good building practices to be adhered to in Finland.

### CE marking of construction products

By CE marking of construction products the manufacturer attests that the product complies with all the applicable EU directives. However, CE marking alone does not guarantee that the product is suitable for use in Finland.

### Product and contracting certificate

VTT Technical Research Centre of Finland has approved a general code of conduct "CERTIFICATION CRITERIA FOR BUILT-UP BITUMEN ROOFING SYSTEMS". VTT and the roofing

industry have together specified the requirements contained in the guideline.

The objective of the guideline is to ensure the suitability of roofs built for Finnish conditions and to facilitate the choice of methods and materials at different stages of the construction process.

The first section of the two-part guideline provides the specifications for built-up bitumen roofing required in Finnish climate conditions. Built-up roofing systems certified according to the specified criteria are suitable for use in Finland independent of the manufacturer.

The second part of the guideline defines the requirements for roofing work, accessories and structures.

To obtain a certificate granted by VTT a contractor must undertake to fulfil the requirements of both parts of the above publication as applies to both their activities and materials employed.

# Low Pitched Roofs

Roofs with a pitch of 1:10 or less can be considered low pitched roofs. The basis for the design should be that the required falls are already incorporated in the structure. Roofs with a pitch of less than 1:80 should not be designed. Roofings and the related detailing of low pitched roofs should be such as to withstand water pressure.



## Design of low pitched roofs

Design of the waterproofing system must be made and these should include its construction and detailing, specification of materials and accessories, the fixing method and the fixings to be used, the joining of waterproofing and other structures, and drainage. In addition the projected life span of the building, the desired level of failsafe operation and the possibilities of constructional repairs should all be taken into account. Aspects of safety at work during installation and roof use should also be given consideration in the design.

### Life span of a roof

The projected life span of a building is of major significance in its design. In a similar fashion the projected life span of the roof affects its design, involving the design of its construction, the materials employed and its detailing. The Finnish Roofing Association's life span calculator ([www.kattoliitto.fi](http://www.kattoliitto.fi)) can be used to compare the effect of different constructional solutions and materials on the estimated life span of a roof.

### Roof structures

The roof structure is a complete system usually consisting of a structural frame, air barrier, vapour barrier, insulation, waterproofing and incorporating effective ventilation. The construction may be designed in many different ways. The specified materials affect the constructional details and vice versa.

### Air barrier

The air barrier is a layer of the building envelope that mainly serves to stop undesired flow of air through it. If the building is used for activities that produce a lot of vapour, if the roof construction cannot withstand vapour or if vapour cannot escape from the air barrier must be replaced by a vapour barrier. Special attention must be paid to the sealing of all penetrations.

### Vapour barrier

The need for a vapour barrier and ventilation depends on the planned roof system. The warm air inside the building always contains water vapour. This vapour has a tendency to escape through the building fabric into the drier outdoor air, especially during the cold season. Moisture passes through or into the building fabric:

- due to air leaks (convection) if there are gaps or poorly sealed parts in the

Table 1

**Recommended vapour barriers**

Material	Vapour resistance (m <sup>2</sup> sPa/kg) × 10 <sup>9</sup>	Seal at details
Bitumen membrane TL 4 (K-EL 50/2200)	500	++
Bitumen membrane TL 2 (K-EL 170/3000)	1600	+++
Scrim reinforced aluminium/ polythene laminate	2500	+
Bitumen membrane K-EL50/2200 AL 0,08	10,000	++

When using bitumen membranes, penetrations through the vapour barrier can be securely sealed by using purpose designed collars.

Table 2

**Vapour barrier to be specified according to prevailing conditions**

Roof structure	Relative humidity in winter	
	below 50 %	over 50 %
Lightweight timber/boarding roof	Scrim reinforced aluminium/ polythene laminate	–
Folded steel sheeting <sup>1)</sup>	TL2, Scrim reinforced aluminium/polythene laminate	–
Hollow core slab	TL 2	TL 2, K-EL AL
Cast-in-situ	TL 2	TL 2, K-EL AL

<sup>1)</sup> Hard mineral wool or appropriate building board to be installed over folded steel sheeting as base for the vapour barrier.

fabric and there is an air pressure difference between its opposite sides or

- through the different layers of the building fabric (diffusion), depending on the varying vapour resistance of different materials; in this case there is a different partial vapour pressure on the opposite sides of the building fabric and it tends towards equilibrium, which causes vapour to permeate through the different layers of the fabric.

Problems occur when a structure incorporates such an impermeable component (e.g. waterproofing) on the cold side of the dew point that vapour cannot penetrate it but is trapped within the structure. If in such a case there is inadequate ventilation, timber structures can in the worst case suffer from wet rot. In other structures problems include accumulation of water within the structure, frost damage, water dripping back into the interior space, reduced insulation capacity of thermal insulants etc. For these reasons the vapour must be prevented from entering a structure.

In principle, a ventilated structure is always safer than an unventilated one, and this also means that vapour trapped during construction can better be eliminated from the structures. Until recent years we have all too often simply used a thin plastic membrane as a vapour barrier instead of a well functioning vapour control layer. However, this membrane has not proved sufficient to withstand the stresses caused by installation work and has not provided an air and vapour tight seal, particularly during the cold season. As the mechanical fixing of roofings is gaining ground, it is important that the vapour barrier is sealed against the fixings that penetrate it. Membranes that fulfil the TL2 criteria are suitable for use as a vapour control layer. The vapour barrier has major significance for the estimated life span of a roof. Consequently the Finnish Roofing Association recommends the use of elastomeric bitumen membranes for vapour control. TL2 class membranes can also be used as waterproofing during construction and they also have good mechanical resistance.

## Ventilated roof structures

In a ventilated structure the vapour permeating from indoors through the fabric is expelled by ventilation. For ventilation a ventilated gap or a ventilated layer of insulation is incorporated in the structure. A ventilated structure is made airtight to prevent the leakage of air from indoors.

The ventilated space must be generous, at least 200 mm, when the roof pitch is <1:20 and at least 100 mm in roofs steeper than that. The minimum dimensions for ventilation gaps are not to be compromised in any part of the structure. The exhaust air ventilators must be as high up as possible and the replacement air ventilators must be placed low. Due to the level difference and the tendency of warm air to rise, this arrangement provides, natural ventilation of the roof.

## Ventilated voidless structures

Ventilated voidless structures include mineral wool, EPS and Leca gravel roofs.

An absolutely faultless vapour barrier is indispensable for the functioning of a ventilated voidless structure. In mineral wool and EPS roofs the construction time moisture is removed by the means of grooved insulation slabs as well as by suction ventilators linked to collection channels and gaps in the eave soffits. In Leca gravel roofs the construction time moisture is removed by ventilating the gravel layer.

## Unventilated roof structures

### Pressurised roof construction

A pressurised roof construction allows air and vapour to penetrate into the interior. The pressurisation of the ventilated space causes a steady ingress of air through the fabric from the ventilated space into the building. In practice pressurised roof systems are rare. This system cannot be recommended as it is sensitive to risks.

## Warm roofs

A Siporex roof system is an example of a typical warm roof construction. In this system moisture can move between the interior and the roof structure. This structure cannot be recommended for applications where the humidity of the interior is higher than normal.

## Inverted roofs

In inverted roof systems falls are ready made in the structural roof. The waterproofing is installed directly on the roof deck. The waterproofing also acts as a vapour barrier.

Insulation is installed on top of roofing and covered with a filter fabric. The final layer, e.g. gravel ballast, concrete slabs, is heavy enough to keep the insulation in place.

The insulation must be resistant to moisture, water pressure, mechanical stresses and frost. It must neither absorb water nor lose its insulation capacity in varying weather conditions. The intention is that most of the rainwater is drained off along the top surface of the roof structure. Rainwater is not channelled through to the roofing membrane. It is recommended that the top membrane underneath the insulation is of a type dressed with chippings to ensure the drainage of water that has entered through the insulation layer. Alternatively you can use insulation slabs grooved on the underside or a filter fabric or a drainage membrane on top of the waterproofing.

An inverted structure is ideal in many ways: the vapour barrier is always adequate and the roofing membrane is protected from frost, mechanical stresses, solar radiation, air pollution and other stresses.

It must be noted though that an inverted system is usually more difficult to repair than other structures and therefore its execution calls for good workmanship and great care in design.

The detailing of an inverted structure is dealt with more specifically in the section on Trafficable roofs, decks and terraces.



## Roof decking

The decking underneath waterproofing must be stable and even. Harmful gaps and sharp upturns are to be avoided. The structure must be rigid enough to avoid depressions of the roof surface that could damage the roofing or prevent drainage of water from the roof.

The decking must have a sufficient fall. It is advisable to incorporate the angle already in the loadbearing structure. The actual roofing cannot be used to make the falls. Roofing membranes should be chosen according to the slope. The requirements for the roofing are the more stringent the lower the pitch of the roof. A sufficient slope ensures a good and economic result.

When choosing a decking material the functioning of the entire system must be considered and attention must also be paid to the requirement for ventilation and a vapour barrier.

## Timber substructure

The substructure must be even and rigid. The substructure is usually cross ventilated. The ventilation gap must be sufficient (min. 100 mm). The exhaust air vent is situated as high as possible and the air inlet vent as low as possible, so as also to allow gravitational ventilation of the structure.

## Board decking

The decking is constructed of rough-sawn T&G boards with a max. width of 95 mm. The minimum thickness is 20 mm when the support spacing is 600 mm (see table). The boards must be square edged and dry. The moisture content may not be over 20% of the dry weight. Lengthwise joints are to coincide with supports and the minimum board length is 2x support spacing. Allowance for moisture and thermal expansion of boards should be made by leaving a sufficient gap between them. Each board is nailed to each roof truss with two HDG nails of no less than 70 mm in length. The board deck is stiffened e.g. with crosswise band steel braces, which will stabilise it against possible lateral forces caused by wind or snow loads.

## Timber panel decking

Appropriate building board (e.g. exterior quality plywood) may be used to construct the roof deck. The boards should be fixed according to the manufacturer's instructions. The minimum board thicknesses are given in the table below. The joints in the direction of the supporting members should coincide with the supports. The joints perpendicular to the supports should be tongued and grooved to prevent either edge from protruding /sagging or this should be prevented by other practicable construction.

The panels should be installed so that the perpendicular joints do not coincide with one another. The panels should span at least two support spacings. At the joints expansion in width and length due to moisture and thermal movement should be taken into account.

*When using a panel product decking, comply with the manufacturer's instructions.*

Table 3  
**Minimum thicknesses for timber product decking**

Support spacing c-to-c/mm	Thickness of rough sawn T&G boards mm	Thickness of plywood mm
600	20	12
900	23	15
1200	28	19

*Snow load 1.8 kN/m<sup>2</sup>, point load 1.0 kN*

## Concrete decks

A concrete deck may be of solid concrete, aerated concrete or concrete with lightweight aggregate. The structure may be cast-in-situ or of precast slabs. The surface finish should be equivalent to a concrete surface produced with a wooden float, also where joints are evened out with filler.

If appropriate the concrete deck can be subdivided into areas by means of contraction joints. The spacing between contraction joints is usually 10 - 20 m, depending on the size and shape of the cast areas. A contraction joint is usually

formed at the junctions of different building elements and roof areas.

As a general rule, to avoid the necessity for contraction joints, the effective thickness of a concrete slab cast over lightweight aggregate should be less than 40 mm and the mix should contain cement less than 250 kg/m<sup>3</sup>. A gap of approx. 20 mm must be left between a concrete slab and other structures e.g. by placing a strip of mineral wool along the edges.

On trafficable slabs and outdoor decks, ensure that the concrete surface is sufficiently clean and dry and free from laitance, which prevents adhesion, before installing an underlay membrane. If there is a large amount of laitance or if there are special requirements for the adhesion of the roofing membranes, excess laitance must be removed mechanically. Application of a bitumen solution can be used to improve the adhesion of the roofing membrane to the subsurface.

## Insulation slab substrate

When using thermal insulation slabs as substrate for roofing a sufficiently impermeable vapour barrier must be incorporated in the structure to make it effective in Finnish weather conditions.

The slabs are attached to the deck mechanically according to the manufacturer's instructions. Generally it is recommended that the fixings are installed through the underlay membrane (see mechanical fixing). The slab joints must not form a grid pattern, and the joints in different layers must be staggered. Two-to-three slab layers are recommended for roof structures, as the thermal insulation thus forms a better fit with the loadbearing structure and a better seal is provided at slab joints. The seal at slab joints can be improved by a T&G joint system. When determining slab thicknesses you should pay attention to the weight and size of the slabs with a view to their workability and handling.

When forming a substrate for roofing, thermal insulation slabs act as weight distributing layers, which means that the strength properties

of the insulation and roofing material are compatible. The compressive strength of thermal insulation slabs is tested according to EN 826 (at 10% deformation or at yield or rupture).

Depending on the stress and moisture conditions of the roof structure, a suitable insulation system, grooved if necessary, is selected to withstand the long-term and construction time loads.

The grooves must be directional and a collector channel linking to suction ventilators is to be made at the ridge. The supply of replacement air to the grooves also has to be provided for (e.g. by suction ventilators from the soffit or lower parts of the roof. The

system of collector channels should be such as to ensure ventilation around various roof level installations (e.g. smoke outlets).

Thermal insulation slab substrates have been divided into four stress classes, each with recommended compression strength values.

Table 4  
**Insulation slab stress classes and compressive strength**

Use of structure	Bottom and intermediate layers	Top layer
Stress class R1: (light) -ordinary storage building	≥ 20 kPa	≥ 40 kPa
Stress class R2: (normal) - ordinary residential or office building	≥ 30 kPa	≥ 50 kPa
Stress class R3: (heavy) - ordinary industrial building	≥ 50 kPa or > 60 kPa	≥ 70kPa > 60kPa <sup>*)</sup>
Stress class R4: (extreme) - demanding industrial building	≥ 60 kPa or ≥ 60 kPa	≥ 80kPa > 70kPa <sup>*)</sup>

<sup>\*)</sup> the values may be applied when the thickness of the top slab of a layered insulation system is >30 mm and the long sides of the slabs are tongued and grooved.

### Mineral wool

Two to three mineral wool layers, where the top layer is harder and stiffer, are generally used. The top layer is also a thinner layer (20 - 70 mm). It is recommended to use grooved slabs so that the grooving is as close to the surface of the insulation (20 – 70 mm from the top surface) as possible.

With the insulation thicknesses applicable in Finland, only short term max. 20 mm depressions of limited area that do not damage the insulation are permissible.

### Plastic insulation slabs

Plastic based insulation slabs used on roofs, e.g. EPS, XPS or PUR, must be

products specifically manufactured for this purpose.

The compression strengths of graded **EPS** roof insulation slabs are 60, 80 and 100 kPa. The long term shrinkage of plastic based insulation slabs must be less than 0.2%. To prevent long-term shrinkage, the slabs should be heat treated during manufacture or they should be stored for over 6 weeks in a warm (over 15°C) storage facility.

It is not permissible to install a roofing membrane directly over such insulation slabs; instead, a minimum 20 mm-layer of sufficiently resistant mineral wool should be applied. This will act as a substrate for the roofing membrane and a separating layer between the plastic insulation and the

roofing material. When using plastic insulation materials, a good and secure vapour barrier is essential.

**XPS** and **PUR** slabs are used in roof structures in the same ways as EPS slabs. As a general rule, XPS slabs are recommended for inverted systems, whereas EPS and PUR slabs are unsuitable for such applications.

### Cellular glass

**Cellular glass slabs** are bonded to the substrate and to one another with a hot bitumen solution. If executed correctly, the system is almost completely impervious to water vapour, eliminating the need for a separate vapour barrier. The roofing membrane is also bonded directly to the cellular glass layer.





# Roofing systems

Roofings for low pitched roofs should be continuous, i.e. their seams must be able to withstand water pressure. In this case feasible materials include different types of membranes.

When choosing a roofing system you should take into account the various stresses it is subjected to during construction as well as in the long term. The choice of roofing has a direct impact on the life span of the roof. With correct roofing choices, a life span of 50 years is feasible. For bitumen roofings a life span calculator can be used to estimate the life span of the chosen system. When choosing a roofing material and system the following basic requirements should also be taken into account:

1. The roof drawings of the building and necessary sections
2. The relative heights of a roof structure
3. Minimum pitches including allowance for structural sagging
4. The joining of roofing with interior surfaces and walls
5. The joining of roofing at eaves and verges and their correct shape
6. The location of roof-level plant rooms and AC flues so as not to prevent the drainage of water
7. The location, type and plumbing of roof drains and the routes of water flow on the roof
8. Structural and roofing movement joints
9. Penetrations in roofing and their distribution (sealing and material)
10. Type, quality and arrangement of roofing membranes
11. The fixing of the membranes allowing for wind load requirements for mechanical fixings, their location and distribution in different parts of the roof.
12. Type, quality and arrangement of thermal insulation
13. Safety at work considerations on the roof (allowance for railings, organisation of work etc.)
14. Protection of the roof during construction period

## Bitumen membranes

In professional contracting the principle material is modified bitumen membrane meeting the applicable product class standards.

Modification, i.e. the use of additives, provides bitumen membrane qualities that improve its functional properties and durability. The most common modification compounds include SBS rubber and APP. SBS rubber improves especially the cold properties of bitumen membranes and makes the bitumen mass elastic. APP improves in particular the heat resistance properties of bitumen membranes without compromising the plastic properties of bitumen mass. At present all modified bitumen membranes manufactured in the Nordic Countries are modified with SBS.

## Two-ply roofing

Two-ply roofing forms a continuous barrier with two membrane layers that are bonded or torched together. The joints of the top and bottom layers should be staggered. This provides a resistant and durable system that minimises the risk of leakage in the event of damage or other failure. A two-ply system is a more secure option than single-ply roofing.

## Single-ply roofing

There are also membranes on the market that are designed as single-ply roofing. When a roof has sufficient pitch, a resistant and durable roofing can be achieved even with these products. The steeper the roof pitch, the more viable a single-ply roofing is as an option.

The minimum pitch for single-ply roofing is 1:40. The Finnish Roofing Association's recommendation for minimum pitch is 1:20. The most important factor is not the number of membranes but the functioning of the system and careful workmanship.

## Rating of bitumen membranes

A roofing solution is selected with reference to a product and use classification taking fire ratings into account (type approvals of the Ministry of the Environment). The product rating defines the minimum requirements for membranes and the use classification defines membrane combinations for different roof pitches.

The rating makes it easier for the client and the designer to compare different systems and it promotes competition in practice: in the invitation to tender the applied membrane system/s can easily be specified so that bids are comparable with one another.

A product certificate awarded by VTT indicates the properties and product class of a product.

## Use classification of bitumen membranes

Roofing systems are divided into four categories according to roof pitch: VE20, VE40, VE80, VE80R. These categories indicate the minimum pitch of a roof, i.e. the minimum pitch for VE40 is 1:40. In each use class it is advisable to avoid the absolutely minimum pitch when selecting a membrane system.

Table 5 indicates the roofing system for each pitch with membranes that comply with the product class (TL) requirements of Table 6.



### To be noted in roof pitch rating:

1. The class of a roof valley is determined by the pitch at the base of the valley. When applicable, the normal valley strip width is three times the membrane width (1.0 m membrane).
2. In low pitched, inward sloping roofs it must be ensured that the joints of single ply roofing are durable and watertight and that joints at various junctions are faultless. A two-ply system should generally be used in valley areas.
3. The use classes for structures apply to both newbuild and refurbishments. The Finnish Roofing Association does not recommend roofs with a lower pitch than 1:80. If a roof has a lower pitch and its angle cannot be increased (e.g. for reasons of facade or load capacity) the use classification VE80 may be applied.

There should be no pond formation after rainfall or melting snow on a finished roof. At places a small amount of water retention, mainly due to roofing joints, is permissible, however, no more than 15 mm.

Table 5

#### Use classes of bitumen membranes

Roofing system	VE20 (1:20)	VE40 (1:40)	VE80 (1:80)	VE80R (1:80)
TL1	●	●		
TL4 + TL3	●			
TL4 + TL2	●	●		
TL4 + TL1	●	●		
TL3 + TL3	●	●		
TL3 + TL2	●	●		
TL2 + TL2	●	●	●	
TL2 + TL1	●	●	●	
TL2+TL2+TL2	●	●	●	●
TL2+TL2+TL1	●	●	●	●

● = A recommendable roofing system in each use class

- On heavily trafficked decks and/or on those that are not easily repaired after construction, it is recommended that a roofing system complying with the standards of VE80R be used.
- On terraces and balconies with only light pedestrian traffic waterproofing can be specified to comply with use class VE80 if the structure can be easily inspected/opened.
- In mineral wool roofing systems, the base membrane must be at least of product class TL-3.
- If membranes of different product class are used in a roofing system it is recommended that the cap sheet be of a higher standard. Only for justifiable reasons may the order be changed.





Table 6  
**Product class requirements for modified bitumen membranes**

	Testing method	Requirement	Unit	PRODUCT CLASS			
				TL1 <sup>1)</sup>	TL 2	TL 3	TL 4
Tensile strength, 23°C; longit./transversal	EN 12311-1	min	N/50 mm	750/500	500/400	500/400	250/200
Elongation, 23°C; longit./transversal	EN 12311-1	min	%	15	30	20	2
Elongation, -20°C; longit./transversal	EN 12311-1 mod.	min	%	15	30	10	2
Tear resistance at nail shank; longit./transv.	EN 12310-1	min	N	300	130	100	40
Puncture resistance <sup>6)</sup> dynamic (impact), -10°C	EN 12691	max	Ø mm	20			
Joint tensile strength <sup>6)</sup>	EN 12317-1	min	N/50 mm	500			
Resist. to water penetration <sup>7)</sup>	EN 1928 B	min	kPa	500	300	200	100
Adhesion of granules <sup>8)</sup>	EN 12039	max	%	30	30	30	30
Dimensional stability (longit)	EN 1107	max/min	%	± 0,3	± 0,6	± 0,6	± 0,6
Heat resistance	EN 1110	min	°C	80	80	80	80
Flexibility	EN 1109	max/max					
Bonded membrane, base and top			°C/Ø mm	-25/30	-25/30	-15/30	-25/30
torch on membrane, top			°C/Ø mm	-20/30	-20/30	-10/30	-20/30
torch on membrane, base			°C/Ø mm	-10/30	-10/30	0/30	-10/30
Long term durability <sup>4) 8)</sup>	EN 1296	-					
Heat resistance (after aging)	(EN 1110)	min	°C	80	80	80	80
Flexibility (after aging)	(EN 1109)	max/max	°C/mm				
Bonded membrane, base and top				-15/30	-15/30	-5/30	-15/30
Torch on membrane, top				-10/30	-10/30	-0/30	-10/30
Torch on membrane, base				-0/30	-0/30	+10/30	-0/30
Nominal weight <sup>2) 5)</sup>	EN 1849-1	nominal					
Bonded top sheet			g/m <sup>2</sup>	4500	4000	4000	3800
Torch on top sheet			g/m <sup>2</sup>	5500	5000	5000	4800
Underlay sheet:			g/m <sup>2</sup>	3500	3000	3000	2200
Torch on underlay sheet			g/m <sup>2</sup>	4500	4000	4000	3200
Dimensions	EN 1848-1						
length and width <sup>3)</sup>		declared	mm	declared	declared	declared	declared
straightness		max	mm/10m	20	20	20	20

1) TL Class 1 membranes are generally used for single-ply systems, hence they have more stringent strength and stability requirements than the others. TL 1 class products may also be used as part of a two-ply system.

2) The requirement for minimum weight is designed to ensure the workability and water resistance of membranes. Exceptions to the values may be accepted, provided that with preliminary tests, work samples and other acceptable methods are used to verify the workability and water resistance of the product. However, other class standards are still applicable.

3) The manufacturer/supplier shall provide product dimensions.

4) The product is aged in a +70°C autoclave for 12 weeks, after which the properties of the product are reassessed.

5) The manufacturer/supplier shall provide the nominal weight of the product (MDV). A maximum of 5% deviation (tolerance) of the declared value is permissible.

6) Applies only to single-ply roofing membranes.

7) Deviating from the standard method, the assessment is made in a one-hour-test.

8) Applies only to cap sheets.

## Fire rating

Part EI of the Building Code of Finland contains binding regulations on the fire rating of roofings.

Generally roofings should comply with the requirements of Class B<sub>ROOF</sub> (t2). On an inflammable decking (unless the decking complies with or exceeds the requirements of Class A2-s1, d0) large roof surfaces should be divided into separate areas of max. 2400 m<sup>2</sup> with fire breaks.

The EI does not specify how fire breaks are to be constructed. The EI guideline only mentions that, "The roof surface shall be subdivided into separate areas with vertical or horizontal fire breaks. Where feasible, they shall coincide with the compartment walls below."

### The Finnish Roofing Association's recommendations for constructing fire breaks:

The primary recommendation is to use horizontal fire breaks.

#### Horizontal fire breaks:

- A 5-metre-wide protective zone of ballast with a thickness of  $\geq 20$  mm and grain size of 5-30 mm or a concrete slab with a thickness of  $\geq 20$  mm is installed over the roofing.
- The protective ballast may be replaced by a 5-metre-wide metal surface cap sheet complying with the requirements of the former fire resistance class K I (NT FIRE 006).

#### Vertical fire breaks:

- The height of the fire parapet should be  $\geq 500$  mm and its width 100 mm. It should be constructed mainly of non-combustible materials and have a protective metal capping.
- To isolate the fire break, the sheet metal capping may be replaced with a metal surface cap sheet complying with the requirements of the former fire resistance class K I (NT FIRE 006).

In repair work it should be noted that the structure in question must also comply with the class requirements when finished.

The fire rating of a roofing material can be verified by a type approval decision of the Ministry of the Environment or other reliable certificate, e.g. an approved fire test carried out by VTT.

The type approval applies to both the roofing and the decking below.

## Properties of bitumen adhesives

The roofing contractor must use bitumen adhesives specified in Table 7 to install bitumen membranes. The roofing contractor shall ask the bitumen supplier for a test report, certificate or other reliable document that contains information on the bitumen adhesive complying with table 7. The contractor must ensure the compatibility of the applied membrane and bitumen adhesive.



Table 7

Property	Method	Unit	Modified adhesive bitumen <sup>1</sup>	Blown bitumen <sup>2</sup>
Softening point	EN 1427	°C	95 – 120	90 – 105
Penetration, +25°C	EN 1426	1/10 mm	20 – 70	20 – 40
Flexibility at cold temperatures, diameter 30 mm, thickness 3 mm	EN 1109 mod.	°C	< -15	
Brittle point, Fraass	EN 12593	°C		< -15
Viscosity, +180°C	EN 12495	mm <sup>2</sup> /s	below 10,000	below 3 000
Flash point	EN 22592	°C	> 220°C	$\geq 230$ °C
Temperature in use	–	°C	$\leq 220$ <sup>3</sup>	$\leq 230$

<sup>1</sup> E.g. elastomeric bitumen KB 100

<sup>2</sup> E.g. B95/35, B100/25, B 100/30

<sup>3</sup> Depending on mixing time, temperature and application time. Modified bitumen adhesive easily deteriorates if overheated. Manufacturer's instructions should be followed.



## Other membranes

Other membranes used on low pitched roofs include different types of plastic membranes (e.g. PVC, CPE and TPO) and rubber membranes (e.g. EPDM). Different liquid materials have also been tried on roofs but they have been little used.

Other membranes do not have similar product and use classification as bitumen products. However, with these products it is advisable to verify with the manufacturer that the properties are corresponding.

**PVC** roofing is a typical single-ply roofing material that has been on the market since the early 1970's, and its use became commonplace in the 1980's. Its raw materials include sodium chloride and mineral oil. Fibreglass or polyester fabric is used as reinforcement in PVC roofing. Some PVC roofing products have a surface pattern that has been embossed on the PVC mass during production. PVC roofing is usually mechanically fixed at the joints and the joints are welded with a hot air gun.



# Fixing of membrane roofing

## General

The roof designer shall specify the method of fixing, fixing types and distribution in different parts of the roof, taking into account the properties of the membrane, the decking and the loads the structure is exposed to. Insulation slabs and roofing are usually mechanically fixed to the decking due to the wind suction load and other forces affecting the structure. Each decking material requires its own fixings and fixing methods.

Membranes are fixed to the substrate with bitumen, special mechanical fixings or a combination of both of these.

**Bonding with bitumen** is either done over the whole surface or in parts, depending on the substrate. In a built-up system the membranes are bonded to one another with bitumen over the entire surface area.

It is recommended that the pressure-equalising membrane is attached so that fully bonded membranes form controllable pressure-equalising zones with a practicable surface area (10 - 100 m<sup>2</sup>) (this ensures that in the event of a damage to the structure, water does not spread over the entire roofed area along the pressure-equalising layer. A pressure-equalising membrane is used as a base layer in systems where sufficient moisture to cause moisture pockets might accumulate on the top surface of the decking.

Modified bitumen membranes are bonded with either blown or modified bitumen. The modified bitumens currently used are in practical terms rubber bitumen (e.g. KB 100).

In normal conditions, however, the use of modified bitumen (in practice rubber bitumen) is not practicable in part of the base sheet. Experience has shown that blown bitumen meets the necessary bonding requirements and, if needed, mechanical fixing may be used to secure the roofing.

The Finnish Roofing Association recommends that the base membrane of a roofing system be bonded to the decking with blown bitumen (e.g. B 100/30 tai B 95/35).

The heating of rubber bitumen and its use as an adhesive requires great care and attention, as there is only a slight difference between the highest permissible temperature and the minimum temperature for workability. The margin of working temperatures is significantly wider with blown bitumen. If overheated, the properties of rubber bitumen deteriorate significantly. If not sufficiently heated the workability and adhesion of rubber bitumen suffers.

Cap sheets are mainly bonded by torching, and standardised products always have a bonding bitumen that meets applicable requirements.

In **mechanical fastening** the fixings are specified according to the substrate material, the tear resistance of the membrane, and the thickness and compression resistance of the underlying insulation. If thick flexible materials (e.g. mineral wool) are used below the roofing, flexible fixings that compress under load (e.g. loads imposed by walking on the roof or by snow) should be used.

Wind exerts both pressure and suction loads on a roof. For membrane roofing suction load is generally a greater stress factor than wind pressure. The greatest stresses exerted by wind are exerted on the corner areas of a roof, and therefore the distribution of fixings must be densest there. There is lesser need for extra fixings at edge areas than at corners. The recommendation for roofs is 2 fixings/m<sup>2</sup>, unless wind load calculations indicate a higher frequency.

The number of fixings and their types are specified on a case-by-case basis with consideration for the above factors. A basic number of fixings is used in the central areas of the roof. The specification of the membrane

through which the fixings are to be driven may not be changed without revising the fastening calculations. The weakest point and the point subject to the greatest stress of a structure should always be determined in the calculations.

Roofing fixings are divided into three use classes depending on the corrosion resistance required of them in different roof systems. The use classes are K, KL and KLA. In practice the only ones used in the Nordic Countries are the KLA class fixings, which have the best corrosion resistance.

## Fastening to timber decking

The base sheet is commonly fixed to a timber deck with bitumen by spot or seam gluing. Bonding over the entire surface area is not acceptable. If necessary the fastening is secured with mechanical fixings. For reasons of fire safety, gluing rather than torching is recommended.

## Fastening to concrete decking

Membranes are fastened to a concrete deck with bitumen over the entire surface area or by partial bonding. Mechanical fastening is usually not needed. Generally the substrate is primed with a bitumen solution or if necessary (e.g. on bridge decks) with a heat resistant epoxy compound. On light aggregate roofs priming is not used and the base sheet is only partially bonded to the substrate. In the case of light aggregate concrete slabs membranes are bonded over the entire surface area.

## Fastening to insulation slabs

Membranes are always fastened mechanically to a substrate of insulation slabs, usually down to the loadbearing structure. It is recommended that the base sheet be bonded over the entire surface area to improve the functioning of the roofing system.

## Details

### Penetrations

There are always different types of penetrations in a roof. Their correct and watertight joining to the roofing is vital for the functioning of the entire roof.

Roof drains, lead-through sleeves and suction ventilators must withstand temperatures of  $-40^{\circ}\text{C} \dots + 80^{\circ}\text{C}$  without their properties changing, and they must withstand the effect of UV radiation for at least 10 years.

The penetration materials and systems must withstand mechanical stresses caused by changes in the roof structure resulting from aging, temperature changes and climatic conditions.

The minimum projected life span is 40 years.

### Joining penetrations to roofing

If the penetration itself does not include a flange to which roofing can be bonded, a separate flanged sleeve should be used.

The flange should allow for a minimum 150 mm overlap. The flange of the sleeve is bonded to the roofing between two membranes. If necessary an extra, approx.  $0.9 \times 0.9$  m piece of membrane bonded to the flange and the roofing with bitumen (modified bitumen is recommended), should be used.

All steel structures penetrating the roof should be insulated to prevent condensation. Rounded profiles are recommended for steel components, as they can be joined to the roofing with standard sleeves.

The minimum distance between a roof drain and vertical structures or other penetrations is 1 metre. The same distance recommendation applies to other penetrations as well, both the distance between penetrations and from other structures. Penetrations must not be placed along the bottoms of valleys.



### Roof drains

All water that enters the roof should be channelled into roof drains with falls and into rainwater sewers via a system of downpipes. The roof drain layout should be such that the maximum distance of flow is 15 metres, and water can enter the system without obstruction. The number of roof drains can be estimated by a rule of thumb as 1 drain/200 m<sup>2</sup> when the diameter of the downpipe is  $\geq 100$  mm.

Roof drains are available in acid-proof stainless steel, copper and plastic. The Finnish Roofing Association does not recommend the use of copper roof drains. The recommended minimum diameter of a roof drain and the downpipe is 100 mm. Blockage of the roof drain is prevented by an appropriate dome strainer and, if needed, an outer guard strainer with an adequately perforated strainer lid, diameter 300 - 400 mm and height 100 - 150 mm.

The roof drain must sit below the surrounding roof area, the flange area must be horizontal and provisions must be made for its secure fastening to its base. For example, a roof drain can be fitted into an approx.  $0.9 \text{ m} \times 0.9 \text{ m}$  recess to a base (e.g. plywood) fixed to the supporting structure approximately 20 mm below the surrounding roof surface. Particular attention should be paid to the watertightness of the roof drain joints with the downpipe and the roofing.

The roof drain and the downpipe should be thermally insulated to prevent condensation and fitted with a heating coil to prevent freezing when necessary. The downpipe is connected to the vapour barrier with a separate

flange. To ensure the operation of the system it is recommended that the roofing contractor supply the roof drains and install them in the roofing system.

### Rainwater scupper

The function of a rainwater scupper is to allow rainwater to escape outside the walls into an easily detectable place in case a roof drain gets blocked.

Every roof that has an internal drainage system should be equipped with at least one scupper so that water exiting from it indicates that the roof drains need cleaning.

The scupper should be situated at an eave so that in case of a disturbance in rainwater drainage, water is channelled into it as early as possible. On small roofs (often canopies) rainwater drainage can be arranged by means of scuppers only.



### Lead-through collars

It is recommended that round penetrations be used on roofs, so that the membrane roofing can be joined to them with standard collars. The most common material of the collars is EPDM rubber. The clamp should be of stainless or acid-proof stainless steel.

### Suction ventilators

The purpose of suction ventilators is to let the moisture that collects in roof structures escape. Their layout and number must be determined specifically for each roof.

Suction ventilators are to be incorporated in the roofing system with a solid flange. The minimum height of the outlet pipe is 300 mm. The length of the outlet pipe must be carefully considered in places where snow drifts may form. Suction ventilators may be insulated to prevent condensation or equipped with a condensation collector.

Suction ventilators are fabricated from plastic or acid-proof stainless steel.



### Roof bollards

A roof bollard is a roof top securing device for attaching different suspension and safety ropes, e.g. a painter's or window cleaner's platform. Roof bollards are safety devices and must comply with the requirements of the Standard SFS-EN 1808.

The structural engineer shall specify the bollard type. The fastening of roof bollards to the structure is decided individually as instructed by the manufacturer either by bolting, casting-in or welding.

A roof bollard should have thermal and condensation insulation and it is joined to the vapour barrier and roofing by means of a lead-through collar.

If it is necessary to install permanent structures (advertising signs, condensers etc.) above the roofing, it is recommended that they should be attached to a base of roof bollards as they are sufficiently stable and can be joined to the roofing without compromising its watertightness.



### Upturns

Upturns are an important feature for the functioning of waterproofing. They ensure that water that ponds for whatever reason cannot penetrate underneath the roofing and into the fabric.

Usually the height of an upturn is 300 mm above the finished surface and on roofs at least 100 mm above the overflow level. A 100-mm-upturn is acceptable at door thresholds; however, in these cases it must be ensured that the connection with the door assembly and the wall is absolutely watertight.

With rubber bitumen membrane roofing the roofing is cut along the edge of the upturn and the upturn is constructed of a separate piece of membrane. The upturn is secured with mechanical anchors and it is protected with flashing.

### Eaves

The function of an eave is to prevent water penetration into roof and wall structures and to accommodate the required ventilation for the roof.

On inward sloping roofs the eaves are constructed so that the waterproofing reaches at least 100 mm above the roof surface. The waterproofing thus forms a protective membrane at the eave in case of ponding and channels any water that floods over the eave outside the walled area.

Flashings at eaves prevent the penetration of water into the ventilated space, but must not prevent sufficient ventilation. The water falling on the eaves flashing is channelled towards the roof by tilting the flashing inward at a slope of 1:6.

At high and windy locations a storm strip is incorporated in the eave detail to prevent driving rain rising up the wall and entering the building fabric. The storm strip is installed in a groove made in the wall or its tight fit against the wall is ensured by other means.

Eaves flashing is fixed at sufficiently frequent intervals with correct screws incorporating a seal.

On roof with external gutters a drip is installed between membrane layers at the eave to channel water into the gutter. Another option is to use a flanged gutter system that is connected to the roofing between the membranes. The minimum overlap of the flange is 150 mm and it has to be fixed at sufficiently frequent intervals (approx. 100 mm in a zig-zag pattern) to prevent the thermal movement of the metal separating it from the roofing.

### Valleys

The slope of the valley determines the membrane combination to be used in it. The width of the valley calculated from the bottom is 1.5 x the effective width of a normal sheet in each direction.

It is recommended to lay a membrane along the valley so that its centre coincides with the bottom of the valley. This provides an area with as few joints as possible along the part of the valley that has to withstand the greatest stresses.

### Movement joints

Rubber bitumen membrane roofing does not require separate movement joints for the waterproofing itself. In the event of a structural movement joint under membrane roofing an approx. 500 mm unbonded strip can be used between the deck and the base sheet, or it is otherwise ensured that the base sheet does not adhere to the decking, e.g. by using a cap sheet with the granule coated side down at such a location. If necessary a separate design detail of the movement joint should be provided.





## Trafficked areas, outdoor decks and terraces

Outdoor decks and terraces that often form an integral part of a building require specific professional skill of the designers and roofers in the field.

Nowadays you can find pre-designed, viable models that have been tested in practice. It is worth taking advantage of them to ensure that your courtyard or terrace complies with all the necessary technical and functional requirements.

It is advisable to carry out a water pressure test to ensure the functioning of the waterproofing before covering it. After the water pressure test the waterproofing should be protected either by the final surface structure or by temporary measures.

### Thermally insulated structures

Thermally insulated structures are used if there are heated facilities underneath.

### *Inverted roof structure*

With few exceptions an inverted system is used for thermally insulated outdoor decks and terraces. The waterproofing is below the thermal insulation, protected from mechanical stresses, snow and ice. Its temperature remains stable almost continuously and it doubles as a vapour barrier.

The decking in an inverted system is usually constructed of pre-cast slabs or an in-situ concrete platform. Necessary falls are incorporated by casting in-situ before installing the roofing. The concrete surface finish below the waterproofing should be equivalent to that of a wood float finished surface with the laitance layer removed, as it weakens the bonding.

The layout of the surface structures and rainwater drains should be organised so that the majority of the water falling on the surface is channelled straight into the rainwater drainage system.

The waterproofing is specified according to the Use Class Table for bitumen roofing membranes, applying classes VE 80 or VE80R depending on the use, and should be **bonded to the decking over the entire surface area**. Generally XPS slabs or Leca gravel, products that have low water absorption and sufficient compressive strength, are used for thermal insulation.

### Upturns in inverted structures

Under normal conditions the height of waterproofing upturns is 300 mm **from the final surface level of the outdoor deck or terrace**. A lower upturn is acceptable at door thresholds, however, in these cases you must ensure that it should be attached to the door assembly and the wall in such a way that it is absolutely watertight. The upturn is secured in place with mechanical anchors. Stresses exerted by the surface fabric are prevented by using a separating strip between the surface fabric and the waterproofing

upturn. The upturn above the surface should be protected from mechanical stresses (e.g. snow ploughing). The joint detail between the upturn and wall structures should be specified so that in all conditions water should run over the waterproofing (e.g. in brick or sandwich panel walls the membrane roofing should be joined to the loadbearing inner shell).

#### Roof drains in inverted structures

In inverted structures appropriate, purpose designed roof drains should be used. The drains should be of a double inlet type where most of the water enters through a grating or a strainer. The flange of the drain unit is joined to the underlying roofing, and water entering the top layer of the structure enters the header unit through the perforations at its base. In courtyards the drain unit should generally be equipped with a sump that prevents sand entering the system.

#### Other penetrations through an inverted structure

Particular attention must be paid to the good seal of penetrations as their repair is very difficult. Challenging details include supports of adjacent wall structures, railing supports and ventilation installations.

#### **Enclosed structure**

The waterproofing is installed over the insulation. The system is sensitive to risks and suitable only in exceptional cases. An inverted roof structure is preferable.

The structure should always incorporate a good vapour barrier (e.g. TL2 class bitumen membrane). All water is expelled directly into the roof drain along the roofing over the insulation. Thermal insulation is installed tightly against the fabric avoiding cold bridges.

The compressive strength of the insulation must be sufficient to withstand any imposed loads and to prevent harmful deformation of the roofing (e.g. cellular glass). The waterproofing is specified to comply with use classes VE 80 or VE80R depending on the use of the structure.

#### **Cold decks**

A cold structure is a building element without insulation, e.g. outdoor courtyard decks or car park decks. The waterproofing is installed directly on the screed of the loadbearing deck. The concrete surface finish below the waterproofing should be equivalent to a wood float finished surface with the laitance layer removed. The bond may be improved with a coat of modified bitumen or epoxy solution. An epoxy coating also reduces the loads caused by structural moisture.

In cold decks the roofing can be laid over the decking by gluing/torching and bonding it over the entire surface area or partially only (by using a venting sheet). A venting underlay prevents the occurrence of vapour pockets but makes it difficult to locate a leak.

The waterproofing of decks is specified to comply with use classes VE 80 or VE80R, depending on the use of the structure. Depending on the structure and stresses exerted the surface layer is installed either directly over the waterproofing (asphalt) or may be separated from it by a slip layer (e.g. surface screed).

#### **Green Roofs**

A green roof comprises three layers: a growing medium, a drainage layer and waterproofing. A green roof may be implemented as a conventional roof structure or as an inverted structure.

The depths of the growing medium and the drainage layer depend on whether we want to build a simple green roof or a more elaborate roof garden requiring deeper layers.

In designing a green roof, we have to provide the right moisture content for plants and to ensure the functioning of the waterproofing and also account for structural integrity in view of the extra roof loads. The waterproofing of a green roof must be root resistant or it must be protected by a root barrier. If needed a separate mechanical bar-

rier, e.g. thin rubber sheeting can be laid over the roofing.

For the functioning of a green roof it is important that the drainage layer is correctly dimensioned and that the discharge of water is correctly set out. You should use roof drains specifically designed for green roofs. A green roof often comprises a green area and a living area. It is essential that the water discharge system is designed for the entire roof area. At eaves areas, paving can be used as erosion protection. Where the garden joins wall structures paving is used to create adequate fire protection.

#### **Bridges**

In the waterproofing of bridges it is recommended to use the SYL 6 guideline drawn up by the Bridge Unit of Finnish Road Administration.







## Renovation of low pitched roofs

The objective in roof renovations should be a durable and well functioning roofing solution. The initial problems of a new roof can usually be remedied by individual repair measures. The repair of older roofs often requires more far reaching solutions.

When a roof is nearing the end of its life span, it is advisable to be prepared for complete renovation. This should be implemented before roof leaks begin to cause damage to the fabric of the building.

The life span can vary greatly between individual roofs. As a rule of thumb it can be stated that a twenty-year-old roof covered with blown bitumen membranes can already be at the end of its life span, whereas a modified bitumen membrane roofing system that meets the product and use class requirements can be estimated to last up to fifty years.

Proper maintenance of a roof increases its life span considerably.

### Surveying the condition of a roof

You should investigate the roof's condition, possible damage and need for repair before beginning repair work. A survey of the condition of a roof should be implemented when a leak occurs, if there is another problem with dampness or if renovation of the roof is planned for other reasons.

The survey should be started by collecting the available information on the roof and on any problems that may have occurred. Thus the actual survey can concentrate on the essential issues.

The survey should investigate the condition of the roofing and the structural frame. The survey starts with a visual assessment of the roof's falls, eaves structures, the condition of the roofing surface, the functioning of

water discharge, roof drains, penetrations and flashings. At the same time the ventilation of the roof structure should be inspected.

In the inspection, attention should be paid to the width of ventilation gaps, the number of suction ventilators and the condition of any timber structures and insulation. If desired, the condition of the structures may be further investigated by opening up the roof as needed and by taking samples of the insulation and the fabric of the building; the condition of the vapour barrier may be inspected as well.

### Refurbishment plan

A refurbishment plan is drawn up on the basis of the data revealed by the survey. The refurbishment plan should always include a specification and sufficient detail drawings. The scope of the refurbishment plan should cover the functioning of the entire building element. Particular attention should be



paid to the interfaces of old and new fabric. Waterproofing materials are specified according to product and use class requirements and other materials according to general requirements where applicable. This also ensures an appropriate bidding procedure.

In demolition work attention must be paid to preventing the spread of possible fungal or construction dust into the rest of the building. Note particularly where the building's fresh air inlets and air extractor installations are so as to avoid unnecessary obstruction of the everyday use of the building. This is also significant in view of the safe execution of the repair work. If there is reason to believe that asbestos has been used in any structures of the building (e.g. roof level ventilation ducts) an asbestos survey must be implemented for the demolition work.

### **Conventional roofing repair options**

The design and implementation guidelines for new roofs provided in this manual should be applied to the roof refurbishment as applicable.

In the refurbishment the roof drains should be renewed or replacement outlets can be installed within the old ones. The recommended minimum diameter of the outlet of such drains is 75 mm. If the diameter is less than this, it is recommendable to renew the roof drains. The lead-through sleeves, suction ventilators and flashings should also be renewed. If needed the eaves can be made higher and scuppers installed. Ensure that the upstand of inspection covers and rooflights is sufficient. The unhindered discharge of water to the roof drains should be

ensured if necessary by increasing the inclination of the falls.

After the refurbishment only 15 mm deep puddles are acceptable and these mainly at the seams of the roofing membranes.

### **Reroofing over the existing membrane.**

Sometimes the waterproofing may be left underneath the new roofing where it will protect the roof during construction. Any ballast is to be removed from the top of the old insulation. Any unevenness of the old roofing should be made good and a new layer may be added to provide an even substrate (thin mineral wool slabs). If installing the roofing directly over the existing roofing, a venting membrane is applied and you should ensure the compatibility of the materials.

During the repairs additional mechanical fixings may be applied to the existing roofing to prevent sagging and ridging.

### **Removal of old roofing**

Whenever the old roofing is in poor condition, if there are already many layers of roofing or if the thickness of the roofing cannot be increased or this is undesirable, the old roofing is removed. This also makes it possible to ensure that the condition of the entire decking can be verified and the necessary repairs carried out.

If any damaged structures underneath the roofing system are repaired or if more insulation is to be added, it is makes most sense to combine these with the renewal of the roofing.

Protection for the duration of the work should be planned executed in such a way as to prevent any water damage.

### **Adjusting the roof fall**

Roof falls should always be readjusted if ponding occurs or if the original pitch of the roof is less than 1:80. The pitch may be adjusted by the use of light gravel and insulation slabs or simply by adding wedge shaped insulation boards. Bitumen membranes may not be used to repair the falls.

The adjustment of the falls must cover a sufficient continuous area so that the water is not simply shifted from one place to another. The repair of falls often also necessitates increasing the height of eaves and upturns. The layers of aerated gravel must be ventilated.

### **The repair of a sheetmetal roof with bitumen membranes (detail drawing on page 35)**

If needed/desired a sheetmetal roofing system may be converted into a bitumen membrane system by applying hard mineral wool over the old roofing, thus forming the substrate for the bitumen membranes. This makes the roof noise-free and watertight and prevents slipping of snow and ice from the roof. This repair method is also suitable for sheetmetal roofs with welded seams or gently profiled sheeting.

First a board of equal thickness to that of the mineral wool is installed at the eaves, and the roofing and eaves flashing is attached to this.



# Construction of low pitched roofs

## Hot work regulations

In roofing and waterproofing work the entire currently applicable Hot Work Guideline must be followed. Below are listed some of the basic obligations of the safety guideline. (Hot Work Standard 5900 dating from 2002 and the Fire and Rescue Services Act of 2003)

The checklist/permission defines who is responsible for fire watch after completion of the work and its duration. At some sites it is advisable to extend the fire watch beyond the minimum time (1 hour). The permission/checklist must be updated according to site requirements but at least fortnightly.



It should be noted that it is the contractor's obligation to acquire regular extinguishers for a roofing site. However, the acquisition of special equipment should be agreed upon separately.

## Protection against falling

The principle is that along edge areas where there is a risk of falling, railings complying with safety at work regulations must be built. Exceptions to this may be made if the free fall is less than three metres and there is even ground below. If there is water, rocks or other similar terrain, fall protection is mandatory. The working area may be delimited, for example, with a caution line that prevents access closer than 1.5 metres to the edge (does not obviate the need for a railing). If necessary, a fall protection plan must be drawn up.

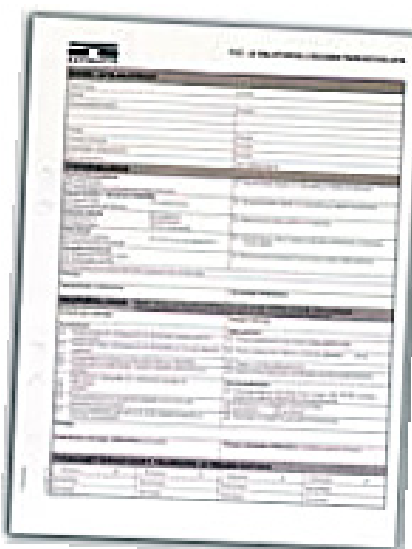

Any openings must also be protected, either by covering them securely and marking them or by building railings or other protection against falling around them. Stepping or sitting on any covers over openings should always be avoided.

## Hot work permit

Every worker carrying out hot work is required to have a valid "roofing and waterproofing sector" hot work permit (valid for 5 years). There is a specific hot work permit for the sector, for which the permit holder must pass the hot work examination required by the Federation of Finnish Insurance Companies and organised by the Finnish National Rescue Association. Completing the hot work examination indicates that a person understands the risks involved in using a naked flame, and knows the basic procedures and work methods to avoid unnecessary risks and to carry out hot work as safely as possible.

## Hot work supervision plan

A contractor must have a hot work supervision plan, which is a permanent guideline on the company's policy to safely carry out hot work.

## Access routes

Access to the roof should primarily be arranged from inside or outside utilising the permanent access routes existing in the building. If there are no such routes, a temporary access route must be constructed for the work period. In most cases this means a site stair tower complying with safety at work regulations. A house ladder does not usually constitute a safe access route as intended in safety at work regulations.

## Hot Work Permission / Checklist for Hot Work

The Checklist for Hot Work / Hot Work Permission must be completed before commencing hot work. The objective of the checklist is that the possible risks at a work site are mapped out before commencing work so as to avoid unnecessary damage. The procedure ensures that the necessary safety equipment can be found at a temporary hot work site and that the workers have the roofing and waterproofing sector hot work permits.

## Safety at work

The fundamental issues in safety at work on roofing sites are protection against falling and the ascent routes. Additionally to be noted as part of safety at work are the scheduling of the work, the placement of materials and equipment on the roof, tidiness of the site, protection of access routes into the building and the need to reserve a sufficient safety zone around the building.

## Canopies

Doorways into the building that are used during work must be protected

by canopies extending a minimum of 1.5 metres beyond the wall line and half a metre on either side of the opening. The door opening must also be allowed for in the railing system by installing a kick board or protective netting above it. Materials may not be stored on the roof above a doorway.

## General tidiness and order

Good order and tidiness of the work-site are part of roofing work safety, both for the workers and for the building users. Materials etc. are to be placed on the roof so that even if they fall they cannot drop off or roll down from the roof. All non-attached building components and materials should be stored so that even strong gusts of wind cannot blow them away from the site. Debris should be collected in plastic sacks or other such containers with attention to the loading of the roof.



## Equipment

### Propane equipment

When using propane, the bottle must be equipped with a hose rupture protection valve and a pressure regulator with a max. pressure of 4 bar. A high pressure hose must be used for propane and it should not be so long that it prevents the functioning of the rupture protection valve (max. length generally 10-12 m). Full propane bottles and those in use have to be stored

and used upright and they must not be heated with a naked flame. Propane bottles should be secured if necessary (e.g. on steep roofs).

More detailed information on propane equipment and their use can be found in the Safety Guide for Roofing and Waterproofing Work (SPEK) and in the Propane Act (711/1993).

### Propane hand torches

A hand held torch is a basic tool when installing membranes by the torch-on method. There are different sizes of torch heads, which influence the heating power of the torch. A correct sized head is important for the result of the work, as well as for fire safety and economy.

The torch should be equipped with a stand and it may not have any other permanent flame apart from the pilot

be equipped with a hose rupture protection valve and a 1.5 bar pressure regulator. A bitumen boiler must have an automated temperature indicator with a thermostat to prevent the overheating of bitumen. The operation of the thermostat must be inspected at least once a year. When using modified bitumen adhesive, the bitumen boiler must have a mixer to prevent overheating of the bitumen adhesive.

Boilers with a capacity of less than 50 litres need not be equipped with a thermostat. They have to be placed in a protective metal basin with a sufficient capacity to contain any bitumen that might leak from the pot.

The boiler must be cleaned and its operation monitored regularly in order to ensure the supply of usable bitumen adhesive, the fire safety of the boiler and the best possible efficiency.

### Hot air guns

Hot air guns are generally used for the bonding of plastic membranes. Their operation is also classed as hot work. Hot air guns may be either propane or electrically powered.

The hot air gun must have a stand that holds the gun in such a position that the hot air current is not directed towards the base when the gun is not in use.

## Working conditions and protection during construction

Weather and other working conditions should be noted when carrying out waterproofing work. Tidiness must be observed of the work site to ensure safety at work but also to ensure the quality of workmanship.

Waterproofing should not be carried out during rain as it prevents proper adhesion. Whenever work is interrupted, a working seam or other protection should be executed to prevent water entering the building fabric. Icy surfaces have to be defrosted and wet surfaces dried before installing insulation. In winter conditions it should be noted that materials may be stiffer, bitumen

light; other operation is actuated by a hand trigger. The pilot light is a small "idle light" that enables the interruption and continuation of work without relighting the torch. Alternatively a piezoelectric hand torch without a pilot light may be used.

### Bitumen boilers

The bitumen boiler must be specifically designed for melting bitumen and it must comply with hot work regulations. The propane hose (5m) should



adhesive may cool quicker and the heating power of a torch flame will be reduced. In cold winter weather it is recommended that the membranes be stored in a warm place prior to installation. The material manufacturer's instructions must be followed also as regards the installation conditions.

At newbuild sites the commencement of interior work may be speeded up by using the vapour barrier as waterproofing during the work. In this case at least TL2 class membrane should be used, sufficient falls must be made in the vapour barrier substrate, and vapour barrier level roof drains should be installed, to which the final roof drains are then joined.

Demolition work is often necessary in connection with refurbishment. In such circumstance particular attention should be paid to the protection of the roof during construction; if needed a special protection plan is drawn up and this can be submitted to the client for approval.

Especially in winter conditions or building sites of long duration it is recommended to use weather protection, particularly during refurbishment.

### Installation of vapour barrier

A faultless vapour barrier is of vital importance for the life span of the entire roof structure. The vapour barrier material should therefore be such that its joints can be sealed well and penetrations can be joined securely to it.

With elastomeric bitumen membranes the joints can be sealed securely when the decking is even. On a decking of corrugated sheeting a layer of hard mineral wool or suitable building board should be used to even out the substrate for the vapour barrier.

Penetrations are joined to elastomeric bitumen membrane with sleeves. Elastomeric bitumen membranes are particularly well suited for roofs where mechanical fixings have to be used, as elastomeric bitumen tightens around the fixings.

When using a plastic membrane as a vapour barrier (can only be used in very well ventilated roofs), the joints should be sealed with suitable tape or butyl sealant. The joints must last for the entire lifetime of the roof. Industrially produced sleeves should be used at penetrations.

Where the roof joins other elements, the vapour barrier should be joined e.g. to the vapour barrier of the wall, and it should be ensured that settling of the structure does not break the vapour barrier.

### Installation of insulation

The functional requirements of the structure should be taken into account in the installation of insulation.

A vapour barrier adjoining insulation must be installed as close as possible to the warm inner side of the structure. If necessary 20-70 mm hard roof insulation mineral wool can be used as a substrate for the vapour barrier,

either to even out the surface or if the vapour barrier is used as waterproofing during work in winter conditions.

The ventilation grooves of a ventilated enclosed structure should be placed as close to the exterior surface, generally 20–70 mm from the upper surface. The continuous ventilation grooves are directed from the eave to the ridge and they are connected to collector channels at both ends.

The functioning of the whole structure is ensured by placing collector channels at the eaves and the ridge. In a roof with more than two slopes the collector channels have to be installed on the ridge of every slope and in every valley.

Ventilation is arranged by using suitable suction ventilators in the collector channels or a ventilation gap in the eaves.

When using slab type insulation, the joints should be staggered and it must be ensured that they do not form a grid pattern.

Insulation slabs are secured with mechanical fixings. For the most part the fixing is done from the joints of the underlay sheet at the same time as the membrane roofing system is installed. The type of fixing and their layout is specified in the structural drawings/specs and can be supplemented by bitumen gluing. If necessary, to prevent the movement of the slabs during roofing work, the roofing slabs may be secured with mechanical fixings before installing the roofing.





## Installing bitumen membranes

Bitumen membranes are always installed to form a totally sealed and continuous waterproofing, including all joints with the building fabric and various penetrations. The installation method is given in the building specification or other design documents. For the functioning of the roof it is important that all details, penetrations, upturns, etc. are executed carefully according to instructions and good working practices and using appropriate materials and accessories for installation.

### Fixing methods

#### **Bonding with adhesive**

The bonding of bitumen membranes is done with hot (molten) bitumen. **Elastomeric bitumen membranes** (SBS) are bonded with either blown or elastomeric bitumen. When using elastomeric bitumen you should particularly avoid overheating it.

Manufacturer's instructions on working temperatures must be followed. The working temperature of blown bitumen is approx. +190 - +230°C and of elastomeric bitumen approx. +200 - +220°C.

**Plastic bitumen membranes** (APP) are usually not bonded by gluing because their softening temperature is so high that bonding bitumen does not sufficiently melt the membrane surface.

When gluing with bitumen the solution is poured from the can in front of the membrane to be bonded so that it spreads evenly at approx. 1.5 kg/m<sup>2</sup> between the sheet and the decking as the sheet is unrolled. Dry patches or air pockets should not be left between the sheet and the decking. If spot and joint gluing is used the sheets are bonded to the decking with bitumen patches with a diameter of approx. 300 mm and an overall area of approx. 20%

of the total area. Consecutive sheets are always bonded to one another across the whole width of the joint.

#### **Torching**

When torching bitumen membranes, the product must be manufactured for this purpose and it should contain a sufficient amount of bonding bitumen on the entire underside area (usually approx. 1.0 kg/m<sup>2</sup>). With venting sheets, the bonding bitumen should cover approx. 25% of the underside either in spots or strips.

The torching is carried out by heating the bonding bitumen of the sheet while unrolling it. When using a bond under the whole surface sufficient bonding bitumen should be melted so that molten mass travels in front of the roll along its entire width. No air bubbles are acceptable between the sheet and the decking.



The joints between each run have to be torched completely so that bitumen extrudes evenly along the joint. When torching, neither the membranes nor the decking should be heated so much that they are damaged. When torching you should take care not to overheat the cap sheet so as to avoid ridges or depressions, which are detrimental to the result.

Particular care must be taken when working on a timber board decking and near penetrations, eaves and walls. In the case of refurbishment the choice of working method is affected by the dryness of the underlying fabric, accumulated dust and the consequent fire hazard.

### Fixing the cap sheet

When the underlay sheet is properly bonded to the decking it is covered with the cap sheet, glued or torched fully to the underlay. The cap sheet needs no separate mechanical fixing.

### Mechanical fixing

Mechanical fixings are used to combat the various stresses that waterproofing is subject to, e.g. wind loads, movement of the roof and the membranes themselves. Use the planned number of specified fixings. The number of fixings

per metre square is usually different in the central, edge and corner areas of a roof. On a substrate of insulation slabs membranes should be fastened mechanically through the insulation layers, down to the loadbearing structure. Fixings that penetrate only the insulation do not replace the need for mechanical fixing of the membranes.

Attachment is executed at a concealed joint through the lower membrane. At the joint, the overlapping membrane should cover the fixing by a min. margin of 40 mm of fully bonded jointing. With single-ply roofing the width of an uninterrupted joint should be 80 mm.

If there is a large number of fixings in built up roofing, some of the fixings may be installed along the centre on the bottom sheet and then covered with pieces of membrane (min. 200 mm x 200 mm).

When using roofing nails they must be sufficiently long to extend through the decking boards. This prevents the loosening of the nails through movement of the timber due to moisture variation.

In refurbishment projects where there is insulation below the existing roofing and it is securely fixed to the substrate, special fixings that attach

to the old roofing and the insulation may be used.

Before applying the mechanical fixings you should ensure that they are the right type for the roof system, substrate and roofing materials.

At upturns the membranes should be mechanically fixed to the upright surface at sufficient intervals, approx. at 150 mm centres.

### Overlaps

The overlap along the edge joint should be 100 mm and 150 mm at sheet ends. At the end joints of membranes it is recommended to cut away a corner of the lower membrane at the overlap. Consecutive membrane layers should be installed so that the longitudinal joints do not coincide. Underlay and cap sheets are usually installed parallel to one another, as crosswise installation may cause ridging.

With single-ply membranes the overlap along the edge joint should be 120 mm and at sheet ends 150 mm.

The overlaps of the membrane joints should be planned and implemented so that the number of reverse joints is minimised.







## Installing PVC roofing

PVC roofing installed by torching the seams and attaching it to the decking with mechanical fixings or alternatively by using ballast.

If mechanical fixings are used, the fixing layout should always be verified by calculation. The fixings are to be installed at a predetermined distance (30 mm) from the edge of the membrane. The fixing type is specified to suit the substrate and intermediate layer if any. The fixings should be equipped with washers to spread loads. The fixings should be left under the overlap (130 mm) of the following membrane. The membranes are welded together with hot air.

If the roofing is not bonded to the decking it is fixed only along the edge areas with fixing rails and around penetrations with mechanical fixings. A protective material (e.g. a filter fabric) and sufficient ballast (e.g. gravel or concrete slabs) should be laid over the waterproofing. The surface layer thus acts as ballast and weather protection. The roofing is installed evenly so as to prevent ridging.

When welding either by an automated method or manually, the joint of the overlapped membranes is heated with a hot air gun (approx. 170 Co). The joints are pressed together with a weighted roller so that some of the molten mass is extruded out of the joint and a homogeneous joint is formed.

Industrially produced corner and penetration parts are welded manually. In places where standard components cannot be used, the necessary part may be made on-site.

When PVC roofing is installed over bituminous materials it has to be separated from these with a slip layer to prevent the transfer of elastomers and the deterioration of the roofing's properties.

When renewing existing PVC roofing with new PVC material you should ensure their compatibility and keep them separate (e.g. with filter fabric) from one another if needed.

# Quality requirements of contracted work

The following table contains the principle quality requirements for contracted work. It is intended to harmonise the practices of the sector and to clarify what can be demanded of the work and how it should be carried out.

General	<ul style="list-style-type: none"> <li>• Materials and other equipment must comply with the contract</li> <li>• Measures required by the safety at work and fire safety checklist</li> <li>• Adjustment of falls is recommended in roof refurbishment if they are inadequate</li> </ul>
Installation of vapour barrier	<ul style="list-style-type: none"> <li>• The vapour barrier material must be chosen with a view to the projected life span of the roof</li> <li>• Correct vapour barrier material for the system must be chosen</li> <li>• The vapour barrier must be correctly positioned in the roofing system</li> <li>• The substrate of the vapour barrier must be sufficiently smooth, and sharp turns angled to a pitch of 1:5 if necessary</li> <li>• The joints of the vapour barrier must be sealed properly</li> <li>• Suitable sleeves must be used in penetrations</li> <li>• Elastomeric bitumen must be used as a vapour barrier when the roofing is attached with mechanical fixings</li> <li>• Joints between the vapour barrier and other structures should allow for their relative movement.</li> </ul>
Installation of insulation	<ul style="list-style-type: none"> <li>• The ventilation required by the insulation system must be executed as planned</li> <li>• The grooves of the insulation must be correctly orientated</li> <li>• The joints of the insulation slabs must be overlapped and should not form a grid pattern</li> <li>• The top layer of insulation must meet the requirements for roofing substrate</li> <li>• There must be at least two layers of insulation slabs</li> <li>• It must be ensured by protection measures and adequate working joints that water, snow or ice cannot enter the insulation during work</li> </ul>
Roofing substrate	<ul style="list-style-type: none"> <li>• The substrate must be clean and dry</li> <li>• There should be no gaps or sharp, proud edges of over 3 mm in the substrate; projections greater than this should be evened out to an angle of 1:5</li> </ul>
Installation of membranes	<ul style="list-style-type: none"> <li>• Membranes should not be installed during rain, snowfall or hard winds</li> <li>• Membranes must be against one another over their entire area, i.e. no air pockets are allowed</li> <li>• Joints must be 100% bonded; the watertightness of joints is indicated by extrusion of bitumen from the joint</li> <li>• It is recommendable to always overlap the sheet directionally avoiding reversed joints</li> <li>• In built-up roofing, consecutive sheet layers should be installed directionally. There should be no coinciding overlaps in different layers</li> <li>• With single-ply membranes the corner of the underlying sheet is cut off at the end joints (in built-up roofing it is recommended to cut off the top layer corner)</li> <li>• The end joints of consecutive membranes should be staggered (min. recommended distance between end joints is 500 mm)</li> <li>• Fixings according to spec (approx. 2 – 6 pcs/m<sup>2</sup>)</li> <li>• The fixings may not stand proud from the membrane surface even if it is under a load</li> <li>• Overtightening of fixings should be avoided to prevent depressions in the surface</li> </ul>
Upstands and upturns	<ul style="list-style-type: none"> <li>• Upstand edges should be made gentler by adding an angle fillet or with concrete</li> <li>• Membranes must be fixed to the trim</li> <li>• The membranes must be cut at the top edge of the trim and upturns made of separate pieces</li> <li>• The edge of the upturn must be at least 300 mm above the surface of the waterproofing, in inverted roofs from the finished roof surface</li> <li>• Mechanical anchors may be used to secure upturns</li> <li>• The bonding of an upturn to a concrete substrate can be secured with a coating of bitumen solution</li> <li>• At upturns, old membranes that are not attached to their substrate should be removed</li> <li>• Upturns should be protected with flashing, which prevents water seeping behind the membrane</li> <li>• Also on roofs with protective ballast the upturns are always made with granule coated top sheeting</li> </ul>

Valleys	<ul style="list-style-type: none"> <li>• The roofing class of a valley is determined by the pitch of the valley</li> <li>• It is recommended that bitumen sheets be installed along the valleys if there is a danger that the sheets might become detached from the substrate at the valley corner or that ridging might result, which could prevent the free flow of water or even cause joints to open</li> </ul>
Roof drains, sleeves and suction ventilators	<ul style="list-style-type: none"> <li>• Only products made for roof applications should be used Flanges should be fixed between membranes with bitumen and mechanically to the decking if necessary. The overlap of the membranes and the flange should be at least 150 mm. The Finnish Roofing Association recommends the use of an additional membrane piece over flanges.</li> <li>• A roof drain should be placed at the lowest point of a particular discharge area. The drain should be situated below the surrounding roof level, the area for the flange should be level and the unit securely fixed to its base.</li> <li>• It is recommended that the minimum distance between adjacent penetrations and suction ventilators and other structures is 500 mm so that work can be executed properly. Penetrations other than roof drains may not be placed in valleys.</li> </ul>
Flashings	<ul style="list-style-type: none"> <li>• Flashing should be fastened with appropriate fixings.</li> <li>• The vertical part should be fixed at 300 mm above the roof surface and in special circumstances at least 200 mm above it</li> <li>• The lower edge of a flashing may not reach down to the roof surface</li> <li>• The flashings should not have unsightly bitumen stains</li> <li>• The renewal of flashings is recommended in roof refurbishment projects so that their life span equals that of the roofing</li> </ul>
Eaves flashings	<ul style="list-style-type: none"> <li>• The falls of eaves flashings should be towards the roof (&gt;1:6)</li> <li>• A ventilation gap of min. 30 mm should be left between the flashing and the wall</li> <li>• A storm strip should be installed at the eave if necessary</li> <li>• Eaves flashing must extend at least 70 mm below the wall head</li> </ul>
Flashings at upstanding walls and bases of other components	<ul style="list-style-type: none"> <li>• The upper edge of the flashing must be watertight</li> </ul>
Drip edges	<ul style="list-style-type: none"> <li>• The zig-zag fixing of drips at approx. 100 mm centres</li> <li>• No bitumen drips at the front edge</li> </ul>
Finish and workmanship	<ul style="list-style-type: none"> <li>• The max. width of continuous flashes of extruded material from the torch-on cap sheet is 20 mm</li> <li>• Footprints are acceptable if the granular surface is undamaged</li> <li>• On the finished roof, slight ponding, mainly due to joint edges, is acceptable, but max. depth is 15 mm</li> <li>• In refurbishment projects where falls are not substantially adjusted, greater ponding can be accepted</li> <li>• If used, ballast should cover the waterproofing completely and its surface should be even</li> <li>• Roof drains and the roof surface must be clean when work is finished and the roof surface must not be used as a storage or work area without protection.</li> </ul>



# Detail Drawings (Low pitch roofs)

## 1. Timber roof

- Vapour barrier to be specified according to prevailing vapour stresses.
- Min. depth of ventilated space 200 mm.
- Waterproofing to be specified according to the use class table.
- Underlay to be spot or seam glued and mechanically attached along the joints if necessary.
- Cap membrane should be either welded or glued over the entire surface.
- Roofing fire rating  $B_{ROOF}$  (t2)

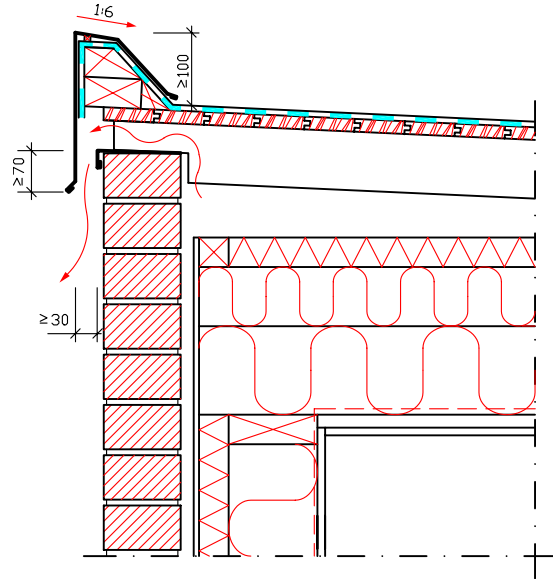

## 2. Substrate of insulation slabs over concrete structure

- Vapour barrier to be specified according to prevailing vapour stresses. We recommend the use of a suitable bitumen membrane (e.g.TL2), to ensure that the vapour barrier remains impermeable at locations of mechanical fixings and penetrations.
- The insulation slabs should be laid tightly against one another, avoiding the formation of a grid pattern and so that the joints of subsequent layers overlap and the ventilation grooves coincide.
- Waterproofing to be specified according to the use class table.
- The underlay should always be fixed with mechanical anchors that penetrate the product partly along the joints and partly through the thermal insulation using fixings appropriate for the base. In addition it is also recommended that the underlay be bonded to the insulation slabs over the entire contact area with bitumen.
- The type and spacing of mechanical fixings to be specified on a case-by-case basis.
- Cap membrane to be bonded over entire surface area by welding or gluing.
- Roofing fire rating  $B_{ROOF}$  (t2)

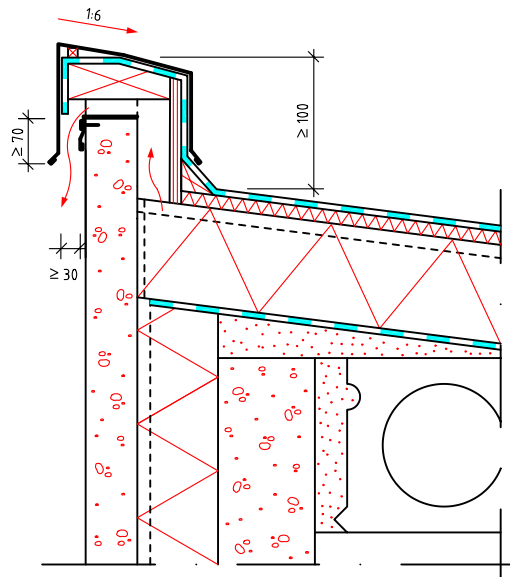

## 3. Lightweight aggregate insulation roof

- Vapour barrier to be specified according to prevailing vapour stresses. We recommend the use of a suitable bitumen membrane (e.g.TL2).
- The lightweight aggregate should be spread and evened out according to predetermined level markers.
- A concrete slab to be cast over the lightweight aggregate, strength class K15 - K20, cement quantity 250 kg /m<sup>3</sup>, thickness 30-40 mm. Alternatively lightweight concrete slabs may be laid over the lightweight aggregate (usually 60 x 250 x 600 mm).
- Waterproofing to be specified according to the use class table.
- The underlay is usually partially bonded to the substrate.
- Cap membrane to be bonded over entire surface area by welding or gluing.
- Roofing fire rating  $B_{ROOF}$  (t2)

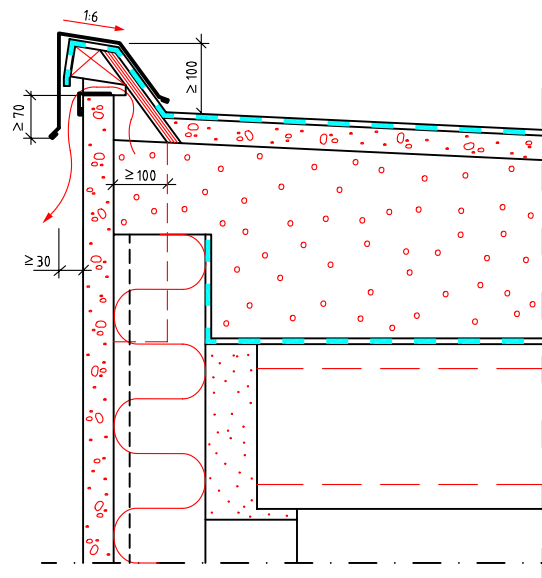

#### 4. Insulation slab substrate over corrugated sheeting, bitumen membrane and vapour barrier

- Hard mineral wool or other suitable board material should be used as a base for the vapour barrier.
- The vapour barrier joints are sealed and it is bonded to the base either partially or over the entire contact area.
- The insulation slabs should be laid tightly against one another, avoiding the formation of a grid pattern and so that the joints of subsequent layers overlap and the ventilation grooves coincide.
- Waterproofing to be specified according to the use class table.
- The underlay should always be fixed with mechanical anchors.
- The type and spacing of mechanical fixings to be specified on a case-by-case basis.
- Cap membrane to be bonded over entire surface area by welding or gluing.
- Roofing fire rating  $B_{ROOF} (t2)$

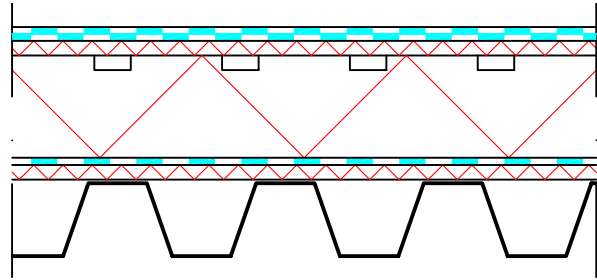

#### 5. Inverted roof

- The falls required for the waterproofing are made in the loadbearing concrete structure.
- Waterproofing to be specified according to the use class table.
- The waterproofing doubles as vapour barrier.
- The lowest membrane should be bonded to the base over the entire contact area with bitumen.
- Cap membrane to be bonded over entire surface area by welding or gluing.
- The insulation slabs (XPS) may be anchored to the base lightly with bitumen.
- The removal of water that penetrates through the insulation layer may be improved by a drainage system between the insulation and waterproofing. The required drainage may be achieved by using grooved insulation slabs or by installing a suitable material between the layers (e.g. filter fabric or studded sheeting used for foundation drainage).
- The filter fabric is laid loosely over the insulation and the edges are overlapped by approx. 200 mm.
- Minimum quantity of protective gravel ballast: 50 mm/ 70 kg/m<sup>2</sup>

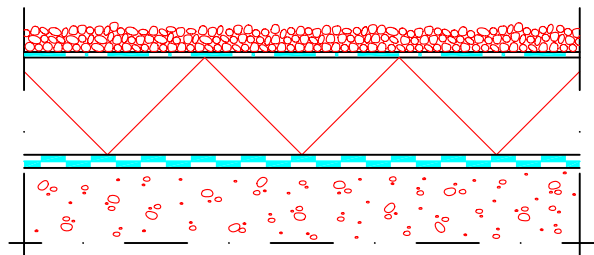

#### 6. Joint between waterproofing and wall surfaces

- The vapour barrier of the roof must be carefully joined to the wall vapour barrier (to be noted in structural design).
- The waterproofing must extend without breaks (without penetrations) up any vertical surfaces joining the roof surface at least 300 mm above the roof surface and 100 mm above the overflow level of the roof.
- On vertical surfaces and the joints of abutting surfaces, cap sheeting should always be used as the topmost layer.
- The waterproofing upturn should be fixed to the wall to prevent it from sagging over time. The upper edge should be anchored with mechanical fixings if necessary.
- An effective joint between the wall surface and waterproofing is to be secured with flashing.
- At doorways the waterproofing must extend at least 150 mm above the final roof surface and must extend at least below the threshold flashing.
- The thickness of the L-profile installed at the junction of the structural profiled sheeting and the wall to be specified in structural drawings. The L-profile should be fixed to the wall and not before the third peak of the sheeting.
- At wall junctions the ventilation of insulation can be executed as shown in the detail or by using a collector channel and suction ventilators. In the latter case the waterproofing is fixed directly onto the wall surface without a ventilation gap.

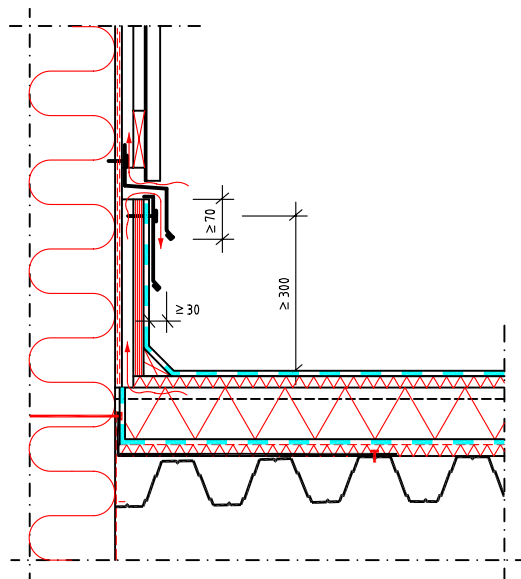

## 7. Roof drains

- Each roof drain is positioned at the lowest point of its drainage area.
- Ensure unhindered flow of water to the roof drain.
- There should be no other penetrations in the immediate vicinity (approx. 1 m) of the roof drain.
- Under insulation slabs it is recommended to use an anchored plywood sheet as an installation base.
- The flange of the roof drain should be joined between membranes by using an extra piece of membrane (approx. 900 x 900 mm) over the flange.
- The roof drain head and the downpipe should be insulated when needed (e.g. in cold roof structures).
- The roof drain can be equipped with a heating coil to prevent freezing.
- The downpipe is joined to the vapour barrier with a separate penetration sleeve.
- The recommended min. diameter of the downpipe is 100 mm and it should extend sufficiently below the loadbearing structure (allowance for connection).

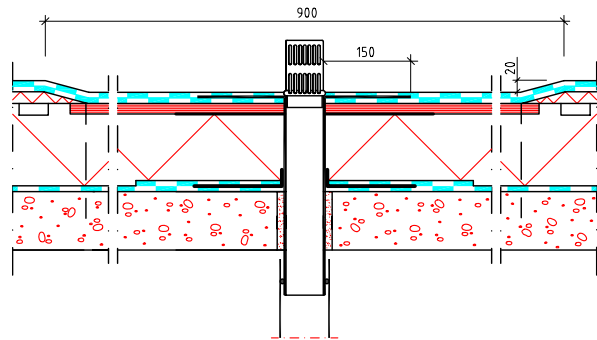

## 8. Penetrations

- Penetrations should not be placed in valleys, close to one another or any vertical structures. If penetrations have to be placed close to one another they should be encased and waterproofed in the same way as upturns.
- Rounded penetrations should be used in roofs so that they can more easily be joined to the waterproofing and vapour barrier with mass produced penetration sleeves.
- The penetration sleeve is joined between membrane layers by applying an extra piece of sheeting (approx. 900 x 900 mm) over the flange.
- In roofs with lightweight aggregate ballast, metal penetrations should be protected against corrosion (e.g. with plastic membrane).

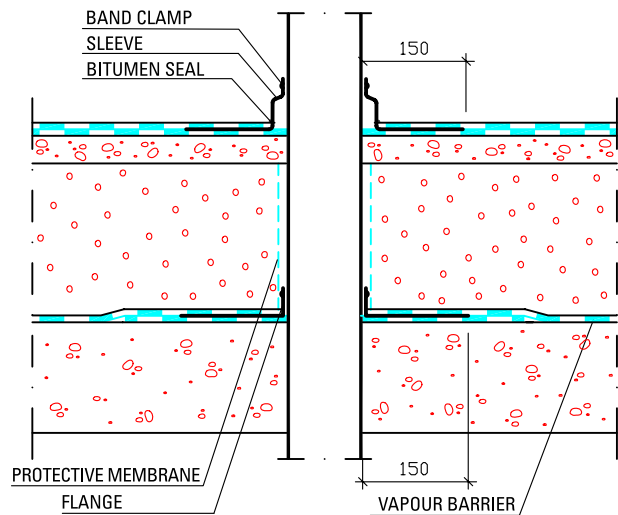

## 9. Suction ventilator

- Suction ventilators are placed on the roof according to the predetermined plan.
- The flange of a suction ventilator should be joined between membranes by installing an extra piece of membrane (approx. 900 x 900 mm) over the flange.
- An opening the size of the ventilation pipe should be made in the underlay and the underlying fabric extending down to the ventilated space.

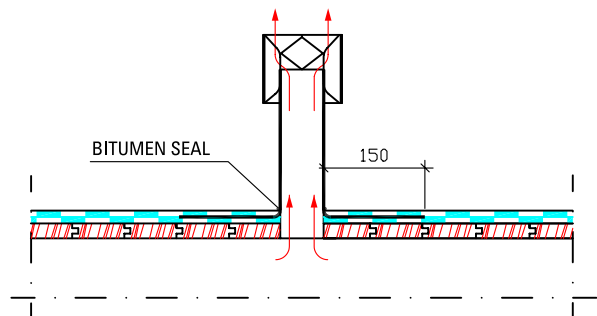



## 10. Roof bollards

- Roof bollards should be laid out according to construction drawings.
- Roof bollards are joined to the waterproofing and vapour barrier with the aid of a penetration sleeve.
- Roof bollards are safety equipment and they must comply with the SFS-EN 1808 standard (or applicable national standards).
- Roof bollards are also used on roofs as bases for various other structures.

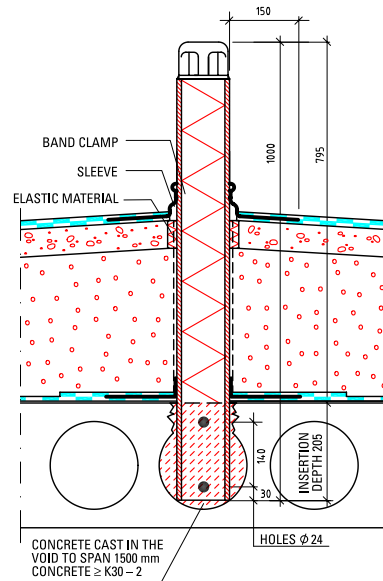

## 11. Waterproofing movement joint

- A movement joint is made with elastomer bitumen membranes by separating it along the joint from its base using a sufficiently wide isolation strip underneath. Modified weldable or glueable bitumen must always be used at the movement joint.
- At structural movement joints there should also be a movement joint in the waterproofing. Their location must be shown in the waterproofing drawings.
- If movement of the deck is exceptionally great, the functioning of each movement joint should be checked on a case-by-case basis.

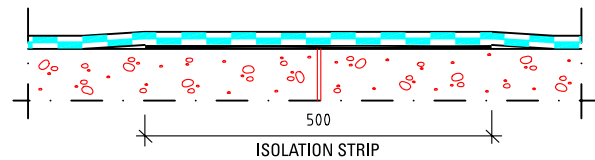

## 12. Fire breaks

- It is primarily recommended to use horizontal fire breaks.

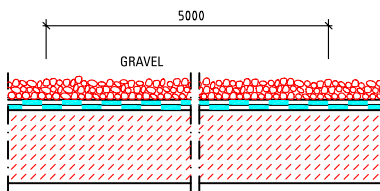

Fig. a

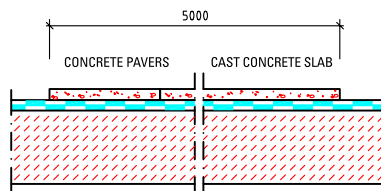

Fig. b

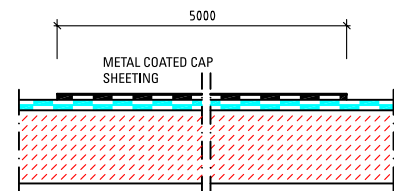

Fig. c

### Horizontal fire breaks:

- A 5-metre-wide protective gravel coating should be installed over the waterproofing (Fig. a), thickness  $\geq 20$  mm and grain size 5-30 mm, or a concrete slab with a thickness of  $\geq 20$  mm (Fig. b).
- The gravel fire break can be replaced by a 5-metre-wide strip of metal coated cap sheeting (Fig. c) complying with the former fire safety class K1 (NT FIRE 006). For countries other than Finland, please refer to applicable building codes.

### Vertical fire breaks:

- Construct a break of  $\geq 500$  mm in height and 100 mm in width of mainly inflammable materials with protective metal flashing (Fig. d).
- The protective flashing may be replaced by isolating the break with metal coated cap sheeting (Fig. e) complying with the former fire safety class K1 (NT FIRE 006). For countries other than Finland, please refer to applicable building codes.

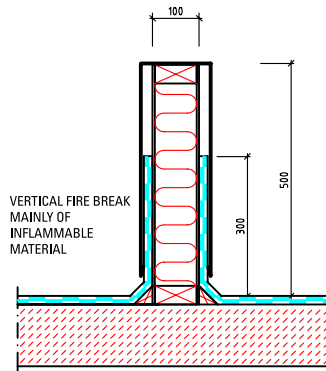

Fig. d

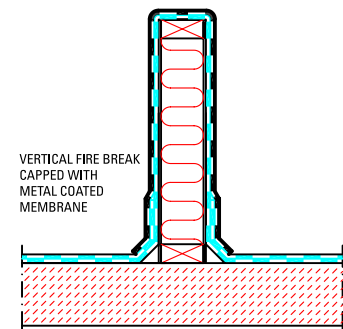
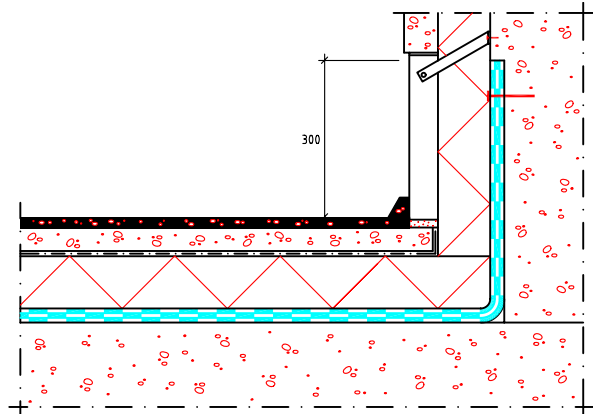

Fig. e

### 13. Inverted system, trafficable deck and connection with wall structure

- The falls required by the waterproofing are made in the loadbearing concrete structure.
- Waterproofing to be specified according to the use class table (VE80 or VE80R).
- The waterproofing doubles as vapour barrier.
- The lowest membrane should be bonded to the base with bitumen over the entire contact area.
- Cap membrane to be bonded over entire surface area, usually by welding.
- The upturn of the waterproofing must be executed so that water possibly running within the wall structure (e.g. sandwich panels) cannot seep between the waterproofing and the wall structure.
- The insulation slabs (XPS) may be anchored to the base lightly with bitumen.
- Drainage of water can be executed by a system of grooved insulation slabs or by using a filter fabric. The drainage can be improved by using a membrane with granular coating as cap sheeting in the waterproofing layer.
- The insulation slabs should be laid tightly against one another, avoiding the formation of a grid pattern.
- The filter fabric should be laid loosely over the thermal insulation with sides overlapped by approx. 200 mm.
- The loadbearing structure usually comprises a reinforced concrete slab as specified in structural drawings.
- The surface layer may be of concrete, concrete slabs, tarmac, etc.
- A water pressure test is carried out prior to covering the waterproofing with other surface layers.
- The compressive strength of the insulation is specified on a case-by-case basis, depending on the load conditions.
- The waterproofing of a trafficable outdoor area must be protected with insulation slabs immediately after the water pressure test.



### 14. Trafficable deck, unheated structure

- The falls required by the waterproofing are made in the loadbearing concrete structure.
- Waterproofing to be specified according to the use class table.
- The lowest membrane should be bonded to the base with bitumen over the entire contact area. Over solid concrete structures a pressure equalising membrane may be applied, especially if the surface is exposed to direct sunlight.
- Cap membrane to be bonded over entire surface area, usually by welding or gluing.
- A water pressure test is to be carried out before covering the waterproofing with surface layers.
- The waterproofing must be protected immediately after the pressure test.

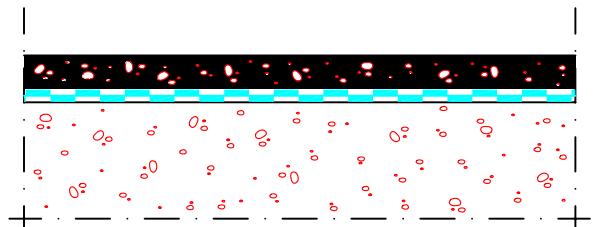

## 15. Alteration of roof pitch and heightening of eaves

- Applicable when renovating roofs, where added roof pitch is desirable. This solution can also be applied when repairing parts of roofs, e.g. at valleys or hips.
- Remove loose aggregate and any other dirt.
- The required pitch is created by applying light weight aggregate.
- Hard mineral wool slabs should be laid over the aggregate, avoiding the formation of a grid pattern.
- Waterproofing to be specified according to the use class table.
- The lowest membrane should be bonded to the base with bitumen over the entire contact area and secured with mechanical fixings along the seams through the underlay.
- The type and spacing of mechanical fixings to be specified on a case by case basis.
- Cap membrane to be bonded over entire surface area by welding or gluing.
- The ventilation of the light weight aggregate layer is executed either via the eaves or with suction ventilators.
- Please note the added height required by the eaves details and roof penetrations.

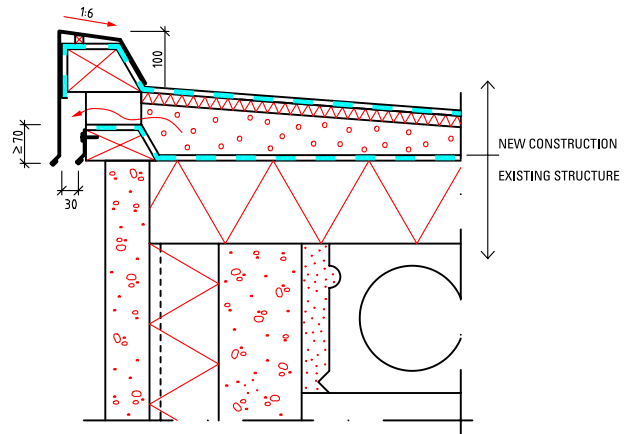

## 16. Refurbishment roof drains

- When refurbishing a roof the roof drains are generally renewed by replacing them. Alternatively you can use refurbishment roof drains.
- It is recommended that any roof drains with a diameter of less than 75 mm always be replaced with new ones.
- A refurbishment roof drain is installed inside the old one. A gasket mounted at the bottom end of the downpipe section ensures a good joint seal. The joined surfaces must be clean.
- The flange of the roof drain should be joined between membranes by using an extra piece of membrane (approx. 900 x 900 mm) over the flange.
- If a slip layer is used or the pitch is altered, a 20 mm depression should be created at the drain location.

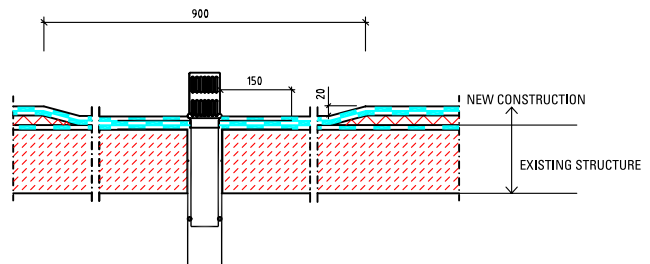

## 17. Refurbishment of a low pitch sheetmetal roof

- Applicable when refurbishing different types of sheetmetal roofs.
- The roof surface is cleaned and any uneven surfaces should be made good.
- In standing seam sheetmetal roofs the hard mineral wool slabs should be dimensioned to fill the space between the seams. The slabs should be sufficiently thick so that even under load the waterproofing does not come into contact with the sheetmetal upstand seams.
- Hard mineral wool slabs are fixed with mechanical fixings through the old sheetmetal roof to the timber decking.
- The membranes are secured along the seams with mechanical fixings.
- The type and spacing of mechanical fixings to be specified on a case-by-case basis.
- Waterproofing to be specified according to the use class table.
- The underlay membrane may additionally be bonded with bitumen over entire surface area.
- Cap membrane to be bonded over entire surface area by welding or gluing.

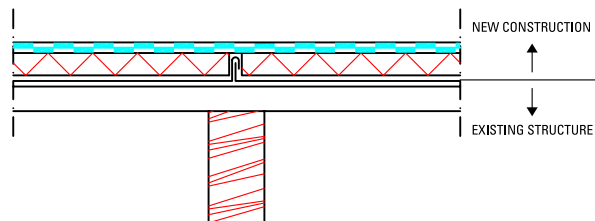





# High pitched roof – the most important facade

The significance of the roof as the fifth facade is emphasised with increasing pitch. A very steep roof with complex geometry may form over a half of the visible mass of a building, and it may then be the dominant element of the whole building due to its prominent position.

The distinction between a high and low pitched roof cannot be defined exactly. As high pitched roofs in this part of the Roofing Systems Manual we deal with roofs with a pitch exceeding 1:20, even if low pitched roofs are defined as ranging from 1:10 – 1:80. Therefore in the range 1:10 – 1:20 particular attention should be given to weathertightness if using systems for high pitched roofs.

Materials classified as discontinuous roofings are mainly used on high pitched roofs. Discontinuous roofing systems include all those with joints or seams that do not withstand water pressure and can only be used on roofs with external drainage. These include various tile, sheetmetal and other corrugated sheet roofings, as well as bitumen roofing shingles and membrane systems with upstand sidelaps. A watertight underlay or membrane is usually installed under such roofings to ensure the weathertightness of the system or to prevent condensation problems.

Continuous roofing systems, which do not require an underlay or a base sheet, are also used on steep roofs. A roofing system with sealed joints can be installed by using cold or hot bonding or self-adhesive bitumen membranes. The minimum pitches for such products vary between 1:8 and 1:20.

## Choosing your roofing

The following criteria have a bearing on the choice of a roofing material:

- appearance
- roof pitch
- roof geometry
- weathertightness of the roof system

- weight of material
- roof noise and sound insulation
- surface friction (slipping of snow and ice)
- the watertightness of penetrations and ease of sealing
- ease/speed of installation
- need for maintenance
- life span

In addition to the choice of material, the following issues also depending on the material should be taken care of:

- adequate ventilation (min. ventilation gap 100 mm and sufficient outlets as high up as possible)
- suitability of underlay/base sheet (underlay classification)
- dimensioning of deck boarding or purlins to suit roof truss layout
- choosing the right fixings for the material
- choosing the right lead through sleeves for the underlay and the roofing

## Roof structures

Steep roofs mostly have a timber structure with a ventilated space above the insulation. The loadbearing frame can be a trussed or rafter system. The structure generally has to contain a vapour barrier or at least an air barrier,



sufficient insulation, a sufficient ventilation gap and the actual roofing laid on a decking compatible with the material. With most roofing systems a separate underlay is required.

## Roof ventilation

Sufficient roof ventilation significantly reduces the risk of moisture damage. As air temperature drops, the humidity in it condenses within the fabric and may cause problems. Well devised ventilation removes the moisture that naturally accumulates in the fabric of the roof. Generally the minimum height of the ventilation gap is 100 mm. In steep roofs sufficient ventilation gaps at eaves are needed and the outlets should be positioned as high as possible to enable gravitational ventilation. A non-ventilated pocket at the ridge is particularly to be avoided, as warm humid air rises and is lighter than the replacement air entering from the eaves ventilation gaps.

Table 8

### Roof pitches

Minimum pitches for roofing systems:

Material	1:3	1:4	1:5	1:6	1:7	1:10	1:20
Bitumen roofing with upstand (batten) sidelaps	X						
Bitumen roofing shingles	X	X	X				
Self-adhesive continuous membrane roofing	X	X	X	X	X	X	X
Pressed sheetmetal roofing panels	X	X	X				
Sheetmetal roofing with upstand joints	X	X	X	X	X		
Corrugated sheet roofing	X	X	X	X	X	X	
Long strip roofing with welted seams	X	X	X	X	X	X	
Fired clay tile roofing	X	X					
Concrete tile roofing	X	X	X				

Note: product specific manufacturer's instructions to be followed.



## Air and vapour barrier

In the Finnish climate a vapour barrier is needed in roofs, preventing the diffusion of moisture through the fabric and doubling as an air barrier. The vapour resistance of the roof vapour barrier should be the better, the more humid the space below or the poorer the ventilation of the roof is. Also to be noted is the structure's susceptibility to damage if humidity condenses within it in winter weather.

The layers of the roof structure should include an air barrier. Air must not pass through (convection) the structure to a harmful extent, as humidity is transported with warm air into the structure and at low temperatures condenses within the structure. Convection also leads to very great heat losses through the fabric of the building.

The vapour barrier should be sealed securely and it must be joined tightly to all penetrations. Special flanged sleeves or similar accessories designed for the purpose must be used. A traditional cross-cut opening taped up does not meet any criteria for a good seal and is not acceptable practice in any application.

## Underlays

A self-supporting underlay without a decking or an underlay felt over decking can be used as underlay roofing in tile or sheetmetal roofing systems. An underlay sheet over solid timber decking must always be installed under bitumen roofing shingles.

Roofing underlays have their own classification and they are divided into types according to application. Self-supporting underlays are divided into waterproof and vapour permeable types. A waterproof underlay must be able to retain moisture on the underside so that water condensing there cannot at any time cause the surrounding fabric to become wet to a harmful extent. A vapour permeable underlay should always allow a sufficient amount of vapour through so as to prevent damaging amounts of condensation on the underside.

Table 9

### Underlay systems used with discontinuous weatherproofing systems.

Weatherproofing system	Self-supporting underlay	Underlay installed on decking
Bitumen roofing shingles	–	X
Roof tiles * Concrete and clay tiles	X	X
Long strip roofing with welted seams	X	X
Sheetmetal roofing with upstand joints	X	–
Profiled sheetmetal * Corrugated and pressed sheets	X	–

The above table and manufacturer's instructions should be followed when choosing an underlay for other discontinuous roofing materials, such as corrugated bituminous sheets, fibre-reinforced concrete sheets or natural stone.

An underlay is not intended as weatherproofing and should not be exposed to UV radiation, rain, snow loads or other exterior stresses for extended periods.

### The classification of underlays

The classification of underlays has been devised with respect to the properties of various waterproofing materials and structural systems used under them.

The underlay used should always meet the minimum requirements and values of the product classification assigned to underlays by the Finnish Roofing Association. The product and use classification defines the minimum level for underlay properties and use with different roofing materials that constitutes good building practice. The use class tables are given in connection with each roofing material.





Table 10

**Classification of underlays for discontinuous roofings**

Property	Test method	Requirement / Unit	UNDERLAYS			
			SELF SUPPORTING		ON SOLID DECKING	
			AKV 1	AKV 2	AKK 1 <sup>10)</sup>	AKK 2 <sup>10)</sup>
Watertightness <sup>1)</sup>	EN 1928,A	min//mmH <sub>2</sub> O (2 h)	W1	–	W1 (200)	W1 (200)
	EN 13111	permeable/non-perm.		W2		
Tensile strength longit./transversal <sup>2)</sup>	EN 12311-1	min//N/50mm			500/400'	250/200'
	(mod. EN 13859-1 Annex A)		400/300'	400/300'		
Elongation longit./transversal <sup>2)</sup>	EN 12311-1	min//%	10	10	30	2
Tear resistance at nail shank <sup>3)</sup>	EN 12310-1	min//N			130	40
	(mod. EN 13859-1 Annex B)		130	130		
Flexibility	EN 1109	max//°C	-20	-20	-20	-20
Dimensional stability (longit.) <sup>4)</sup>	EN 1107	max//%	2,0	2,0	0,6	0,6
	(EN 1107-1 EN 1107-2)					
Ageing properties <sup>5)</sup>	EN 13859-1					
Property after aging	(Annex C)					
* watertightness <sup>1)</sup>	+ EN 1928,A EN 13111		W1	– W2	W1 (200) –	W1 (200) –
* tensile strength - (abs. limit) <sup>6)</sup>	EN 12311-1	min//N/50mm	300/200'	300/200'	400/320'	200/160'
* elongation - (abs. limit) <sup>6)</sup>	EN 12311-1	min//%	7	7	20	1,5
Condensation binding capacity <sup>7)</sup>	VTT-M-06-00058	g/m <sup>2</sup>	declared	declared	–	–
Vapour permeability, μ <sup>8)</sup>	EN 1931	kg/m <sup>2</sup> sPa	declared	declared	–	–
Dimensions:						
length <sup>4)9)</sup>	EN 1848-1	MLV	declared	declared	declared	declared
width <sup>4)9)</sup>	EN 1848-2	MDV	declared	declared	declared	declared
	EN 1848-1					
straightness <sup>4)9)</sup>	EN 1848-1	permeable / non-permeable	permeable	permeable	permeable	permeable
	EN 1848-2					
nominal weight <sup>4)9)</sup> (m <sup>2</sup> -weight) thickness	EN 1849-1	MDV	declared	declared	declared	declared
	EN 1849-2	min//g/m <sup>2</sup>				

- 1) W1 class product, passes EN 1928 A(200mm) test for resistance to water penetration. 1) W2 class product, passes EN 1928 A(200mm) test for resistance to water penetration. EN 13111 is a pass/fail test, where the test max. pass value is 100 ml for penetrating water.
- 2) EN 12311-1 tensile strength test with samples complying with underlay product standard EN 13859-1, Annex A for bendable products.
- 3) EN 12310-1 tear resistance test at nail shank with samples complying with underlay product standard EN 13859-1, Annex B for bendable products.
- 4) When two optional test methods have been indicated, the one marked "-1" is applied to bituminous products and the other marked "-2" for other (e.g. plastic) products.
- 5) The ageing method has been described in the underlay standard EN 13859-1, Annex C. The ageing method is a combination of ageing methods EN 1297 (UV ageing) and EN 1296 (heat ageing). The ageing properties are determined from the aged samples.
- 6) The required value is the greatest permissible decline of tensile strength or elongation from the original result. The result of the ageing test is also acceptable if the result of the aged product surpasses the requirement for a "fresh" sample (even though the decline is greater than the required value).
- 7) There is no test method specified for testing the ability to retain condensed water in the product standard EN 13859-1. VTT has its own testing method, which is here referred to as a testable property outside the product standard that also has no limit value. The result is declared.
- 8) The property/measurement is declared. The declared result is either MLV (manufacturer's limiting value) or MDV (manufacturer's determined value). MLV is a limit value (e.g. minimum) guaranteed by the manufacturer. MDV is a typical value and a certain tolerance is acceptable. See in detail the underlay product standard EN 13859-1 and the applicable test standards.
- 9) Underlay standard EN 13859-1 requires that the maximum "deviation from straightness" is 30 mm/10 m (or directly proportional e.g. 15mm/5 m). The test is thus a pass/fail test.
- 10) Compare with the product classification table of bitumen membranes in the Roofing Systems Manual. In practice the underlay product class AKK 1 is equal to bitumen membrane product class TL 3 and AKK 2 equals product class TL 4.

## Fixings

As a general rule the roofing materials of high pitched roofs are always fixed mechanically. When choosing fixings the manufacturer's instruction must be followed. It is recommendable to order nails, screws and special fixings from the manufacturer in connection with the roofing material delivery. When nails are used, the thickness of the decking should always be taken into account.

## Penetrations and wall joints

There are special sealing accessories for different penetrations and for different roofing materials. The manufacturer's instructions should be followed in choice of materials and in installation. When combining different materials it should be noted that their thermal and moisture movement properties may be very different and this must be given particular attention when the roof system is designed.

Upturns at wall junctions should be at least 300 mm and their watertightness should be ensured regarding both the underlay and the roof covering.

## Rainwater systems

The rainwater drainage of steep roofs is done by means of eave gutters and external downpipes. The gutters and downpipes should be specified according to the roof drainage areas. The fastening of gutters should be such that it withstands snow and ice loads at the eaves. If need be, the gutters and downpipes can be equipped with automated heating cables to avoid excessive ice formation and water overflow.

## Roof safety products

Roof safety products include house and roof ladders, walkways and snow barriers. Roof ladders and walkways are compulsory on steep roofs if there are locations to be accessed for maintenance purposes. Their fixing method is chosen according to the roofing material, and installation should be done as advised by the manufacturer. The National Building Code of Finland (RakMK F2) requires that all entrances, access routes and play and other outdoor living areas used in the winter must be protected against snow and ice falling from the roof. The stipulation also applies to the street or other public area around the building.

Snow barriers are generally needed on tiled and metal roofs and obligatory above access routes etc.. Particularly critical are the type and fixing of snow barriers of tall buildings with slippery metal roofing. The snow barrier should be installed sufficiently close to the eave to prevent dangerous amounts of snow or ice accumulating at the edge area. The snow barrier design should be such that snow cannot pass it by dividing (or by gradual melting) through the barrier. On very steep tiled or sheetmetal roofs, snow barriers are also recommended above penetrations and rooflights.

A safe route should be arranged to access chimneys, ventilation equipment or other installations that need maintenance. This can be ensured by installing a sufficient number of roof ladders or a combination of house ladders and walkways.

In practice rough bitumen membranes and shingles with granular coating do not require snow barriers.

## Safety at work

When work is carried out on a roof, the risk of persons or equipment falling must be considered. When the height at eave or verge is over 3 metres, safety railings must be provided. When doing minor work or when erecting the railings, an approved safety harness and rope should be used if not using a scaffold or a platform around the building. Current safety at work regulations must always be observed in roof work. When doing hot work, applicable hot work regulations must likewise be followed and the workers concerned must have a valid hot work permit for the roofing and waterproofing sector.

## Maintenance

Regular maintenance is the key to keeping roofs weatherproof and to ensuring their durability. An inspection of the roof is recommended twice a year. The Finnish Roofing Association has drawn up separate maintenance manuals for bitumen, sheetmetal and tiled roofs. The maintenance manuals contain detailed maintenance instructions and inspection tables.



## Bitumen roofings on steep roofs

### General

Bitumen roofing systems used on steep roofs include bitumen shingles, sheeting with raised sidelaps and continuous membrane systems. The minimum pitches for different roofing systems are given in Table J1. Bitumen roof coverings are particularly suited for roofs with a complex geometry due to their easy workability and watertightness. Other advantages of bitumen roofing include light weight and noiselessness.

### Decking

The decking is always of solid timber boarding or timber based panels specified according to the roof truss spacing (Table I1). Using timber based panels stiffens the frame structure better than boards. Rough sawn T&G boarding is preferable to close square sawn boarding, although if sufficiently thick they also provide an acceptable deck.

The decking is constructed of rough-sawn T&G boards with a max. width of 95 mm. The minimum thickness is 20 mm when the support spacing is 600

mm (see table). The boards must be square edged and dry. The moisture content may not exceed 20% of the dry weight. Lengthwise joints are to coincide with supports and the minimum board length is 2x support spacing. Allowance for moisture and thermal expansion of boards should be made by leaving a sufficient gap between them. Each board is nailed to each roof truss with two HDG nails of min. 70 mm length. The board deck should be stiffened e.g. with crosswise band steel braces, to stabilise it against possible lateral forces caused by wind or snow loads.

Appropriate building board (e.g. exterior quality plywood) may be used to construct the roof deck. The panels should be fixed according to the manufacturer's instructions. Minimum panel thicknesses are given in the table below. The joints in the direction of the supporting members should coincide with the supports. The joints perpendicular to the supports should be tongued and grooved to prevent proud edges, or this is prevented by other practicable means.

The perpendicular panel joints should be staggered. The panels should span at least two support spacings. At the joints you should take into account expansion in width and length due to moisture and thermal movement.

When using a panel product decking comply with the manufacturer's instructions.

Table I1  
**Minimum thicknesses of timber based decks**

(default values, snow load 1.8 kN/m<sup>2</sup> and point load 1.0 kN)

Support spacing c-to-c/mm	Thickness of rough sawn T&G boards mm	Thickness of plywood mm
600	20	12
900	23	15
1200	28	19

An underlay sheet must always be installed under bitumen roofing shingles. Roofing shingles are installed directly over the underlay without a ventilation gap. The minimum pitch of the roof is 1:5. The underlay membrane must comply at least with the requirements



of product class AKK2. If the roof has exceptionally many valleys or other complex details at least product class AKK1 underlays are recommended. Continuous membrane roofing or roofing sheets with upstand laps over triangular fillets are installed directly over timber decking without underlay with the exception of valleys or similar details.

Table 12  
**Underlay use classes**

Roof structure	Underlay product class	
	AKK1 (TL3)	AKK2 (TL4)
Pitch $\geq$ 1:5 (1:5 or steeper)	X	X
Demanding roof or complex roof geometry	X	–

## Ventilation

Ventilation under the board decking must function in all conditions. The minimum depth of the ventilation gap is 100 mm. Longitudinal ventilation must be ensured at the ridge. The outlet ventilators should be positioned below the verge in the gable wall or, if needed, ridge ventilators are to be used (e.g. hipped roofs and roofs between firewalls in terraced houses. There must be sufficient replacement air inlets at the eave.

## Fixing

Mechanical fixing of bitumen roofing usually refers to roofing nails. Nails must penetrate the roof deck boarding so that moisture movement of the timber does not cause the nails to rise. The fixing points and their density are provided in the manufacturer's instructions. There should be no visible nail heads in the finished roofing with the exception of the cap strips over triangular battens used under sidelaps to provide an upstand.

If visible nail tips are not acceptable on the underside of the deck, short screws with sufficiently wide and flat heads and if necessary washers should be used. Bitumen joints are made either by cold or hot application (not with bitumen solutions). Hot work (torching or bonding with hot bitumen) requires that the workers have valid hot work permits for roofing and waterproofing and that they comply with hot work guidelines.

## Eaves and verges

A drip edge at the eave with a flange of approx. 150 mm is always recommended at the eave. The drip edge should be fixed to the decking with roofing nails or flat headed screws at approx. 100 mm spacings (zig-zag layout) to avoid thermal movement exerting stresses on the bitumen roof-

ing mounted on top of it. Alternatively it is possible to use a traditional eaves gutter (RT 85-10459).

The traditional method where a horizontal strip along the eave is turned over the edge and nailed to the front of the last decking board cannot be recommended, as the nails will eventually be pushed out, and the risk of tearing the folded edge increases.

With bitumen roofing there are many possible verge details.

## Penetrations and wall upturns

Small and circular penetrations (e.g. a stack vent) are sealed with flexible EPDM rubber sleeves. Chimneys, groups of ducts as well as upturns against walls are sealed with bitumen membranes with the upper edge raised 300 mm above the roof surface. The upturn is secured with mechanical anchors and protected with flashing.

The settling of a log frame building is allowed for by building a collar (e.g. of plywood) attached to the roof deck around the chimney and attaching the upturns to this. Possible settling of structures must be taken into account when specifying the dimensions of flashings and upturns.





## Bitumen roofing shingles

### General

Bitumen roofing shingles are manufactured according to the standard EN 544. Their design, measurements and colours vary between manufacturers. The installation instructions and detail also vary slightly but in this manual are presented the general principles of installing bitumen roofing shingles. However, manufacturer's product specific instruction should always be followed.

### Roof pitches and underlays

The minimum pitch of the roof is 1:5. An underlay sheet of at least product class TL 4 (Table 12) must always be installed under bitumen roofing shingles. In roofs with complex geometry or particularly demanding situation, TL3 or even TL2 class membrane may be used. The installation of the underlay should be started from the valley and the sheets on the slopes should be lapped 150 mm over the valley sheet and carefully bonded together. Generally on low pitched roofs the underlay sheets are laid horizontally, and correspondingly vertically on high pitched roofs. In vertical installation the underlay joints may be slightly visible even on the shingle surface.

### Eaves and verges

A drip edge is recommended at eaves. An eaves sheet or shingles are bonded on top of the drip edge flange, as instructed by the manufacturer.

The verges may be detailed in a similar fashion to a drip edge, but in this case bitumen shingles are bonded to the drip edge flange directly without a separate membrane strip. An upstand may also be formed at the verge in various ways, e.g. with a triangular fillet, splayed board (or thicker gauge timber). In this case, the underlay is folded over the verge to form a protective cap over the edge detail, the shingle ends are bonded to the splayed part and/or the top of the blocking piece up to the very edge and finally a flashing specified for the detail is fixed on top.

### Installation of roofing shingles

Bitumen roofing shingles must be nailed down with roofing nails so that the nails also penetrate the upper edge of the previous course and thus ensure that the adhesive surfaces are pressed together. The nailing layout is given in the manufacturer's instructions for each shingle type. The shingles should be bonded together but not to the substrate (underlay).

### Valleys

At valleys a cap sheet (hip or valley membrane) with a minimum width of 70 cm and corresponding to the shingle colour should be installed over the underlay. The roofing shingles are lapped over the cap sheet by at least 150 mm and bonded securely to it.

Using nails for fixing shingles over the valley sheet is not recommended practice.

### Ridge and hips

Ridge shingles are installed over the ridge and hips so that the nails remain concealed. At hips the installation of the ridge shingles is done from the eaves up. At the point where the hip meets the ridge, the shingles are cut in the direction of the angle and not folded over it, to ensure that the nails driven through the ridge shingles penetrate the decking.

### Penetration weatherproofing and other upturns

Small and circular penetrations (e.g. a stack vent) are sealed with flexible EPDM rubber sleeves bonded and nailed over the underlay. The bitumen roofing shingles are cut to accommodate the penetration and are carefully glued over the entire flange.

The upturns around chimneys and multiple ducts are made when the installation of shingles has progressed to the upper edge of chimney. First the upturn at the lower side of the chimney is formed, then both sides and finally the upper side. Roofing shingles are then laid over the top side upturn piece. The weatherproofing of a chimney at the ridge is done last, after the installation of the ridge shingles.



## Bitumen roofing with upstand sidelaps

### General

Bitumen roofing with triangular batten upstand sidelaps is a traditional roofing system much used in the past, as hot work with bitumen was difficult and sometimes too hazardous in terms of fire safety. In addition, there were no viable cold application adhesives to bond bitumen membranes. It was practicable to use triangular battens to make an upstand joint with water running between them, and under normal conditions, exerting practically no stresses on the joints. However, if constructed in the traditional way, the system is classified as discontinuous, and its joints cannot withstand water pressure.

### Roof pitches and underlays

The minimum pitch of a traditional upstand sidelap roofing system is 1:3. An underlay is only used at valleys.

Systems differing from the traditional system are dealt with at the end of this chapter separately.

### Eaves and verges

A drip edge is recommended at eaves, over which a strip half the width (35 cm) of a regular roll is usually bonded, in the direction of the eave and nailed at its upper edge to the deck.

A drip edge can be used at verges, or an upstand may be formed with a

triangular fillet or splayed board (or thicker gauge timber). If a drip edge is used, the outermost sheet is cut along the edge of the drip edge and bonded to it. When an upstand is formed, the membrane is folded over the verge to form a protective cap, and flashing dimensioned to fit the detail is installed on top.

### Traditional bitumen roofing with upstand sidelaps

The sheet width of roofs with a system of raised sidelaps is usually 70 cm. On large roofs wider sheets may also be used, however, in this case the sheets must also be secured to the decking between the battens, e.g. by spot gluing with bitumen adhesive.

When using 70 cm membranes, the spacing of the battens is approx. 67 cm. The top ends of the battens stop approx. 17 cm short of the ridge and the bottom ends overlap the horizontal eaves strip by approx. 10 cm. Both ends should be splayed approx. 20 cm from the end. The bitumen membrane is laid between the battens from the ridge to approx. 15 cm over the eaves sheet. The sheet is nailed at the ridge and the sides to the triangular battens. The lower end is bonded over the eaves sheet and this also conceals its nails. To cover the sheet joints, 10 cm strips of sheeting are nailed over the battens. The strip ends are bonded. The weathertightness of the traditional system can be improved by sealing the

joint between the vertical sheets and the strips over the battens by sealing it with elastomeric bitumen mastic.

### Valleys

The installation of the batten roofing system, as of other bitumen roofing systems, is always begun from the valley. To begin with, a 1 m wide underlay is installed along the base of the valley and fixed by nailing it along the sides at 10 – 20 cm spacings. After this a 70 cm cap sheet is mounted over the underlay and the strips of cap sheet along the eaves.

### Ridge

The job is finished off by bonding the ridge strip (usually a half-width of the regular sheeting) at the top. It is bonded securely on both sides of the ridge and covers the nail head at the tops of the membranes installed between the battens. In a finished roof, nails are only visible on the triangular upstands.

### Weatherproofing of penetrations

Small and circular penetrations (e.g. a stack vent) are sealed with flexible EPDM rubber sleeves attached mechanically to the deck according to manufacturer's instructions. The bitumen membranes are cut to accommodate the penetration and are carefully glued over the entire flange.



Chimneys and similar square ducts are sealed by using pieces cut out from the same roofing membrane as used throughout, and their top edges are turned up the sides of the chimney 300 mm from the roof surface. The upturn pieces should overlap the roofing sheets by approx. 200 mm. In the intermediate space between battens where the chimney is located, the roofing is first installed up to the upper edge of the chimney, after which the upturn sections are installed. First the upturn is formed at the lower edge of the chimney, then at both sides and finally at the upper edge. Here the overlap may be extended further than 200 mm, even up to the ridge.

The installation of the main sheets towards the ridge is continued so that they cover the chimney top end sealing piece. The weatherproofing of a chimney situated at the ridge is done last after installation of the ridge sheet.

### “Modern” upturn sidelap roofing

Sometimes a client may want to use a roofing with triangular battens at sidelaps on roofs with a lower pitch than 1:3. In this case the following factors are to be considered:

- as such the traditional system with triangular battens cannot be used on roofs with a lower pitch than 1:3;

instead a 2-layer system has to be applied.

- at the design stage things to consider include, sheet widths, joint layout and overlaps (e.g. the joints of the underlay may be detectable in some circumstances)
- the use of a skilled waterproofing contractor is recommended
- the work is usually hot work so the workers must have valid hot work permits for roofing and waterproofing and there must be a hot work permission for the project
- it is not recommended to install a traditional wooden triangular batten between the membranes due to the risk of rot



# Continuous roofing systems

## General

Even though discontinuous roofings are mostly used on steep pitched roofs also continuous roofing systems that can withstand water pressure are an option to consider, especially if the roof geometry is complex. Continuous roofing systems can be assembled by using self-adhesive membranes, by bonding conventional membranes with cold adhesives or by hot work, i.e. torching or bonding with hot bitumen.

## Self-adhesive bitumen membranes

The manufacturer's instructions should always be followed when using self-adhesive membranes. The minimum pitch given for a product should not be compromised, and the installation requires a sufficiently high temperature, generally at least +10 °C. The sheets have ready-made adhesive side strips under a removable protective film. The protective membrane is removed and the adhesive strips are pressed together.

Generally the sheets are fixed with nails at the joints and concealed by the adjoining sheet. The end laps of

self-adhesive sheets, upturns and sealing of penetrations is done by cold bonding, using the type of bitumen adhesive indicated in the installation instructions. In continuous roofing systems, an underlay is only used at valleys, where the stresses are greatest. Sidelaps are usually 100 – 120 mm and endlaps 150 mm.

In the finished roofing nails must not remain visible; instead all fixings are concealed.

The membranes may be installed vertically or horizontally. Vertical assembly is recommended in steep roofs. When installing over existing membrane, it is preferable to install in the same direction as before. Joints should be placed at different points compared with the old roofing.

## Gluable bitumen membranes

### Cold bonding systems

Gluable products do not have ready-made adhesive edges. Elastomeric bitumen adhesive should be spread on the joint surfaces over the whole width of the lap. Sidelaps measure 100 mm and

endlaps 150 mm. Sufficient adhesive should be applied to create a good seal, but not in excessive amounts so as to avoid the risk that the solvents soften the top membrane excessively in hot weather or even dissolve it. Cold bonded and self-adhesive products are used in the same way, with the exception of sidelap bonding.

### Hot bonding systems

Hot bonding is not generally used on very steep roofs because hot bitumen easily runs down the roof surface. When the roof slope permits and a hot bonding system is applied, the instructions for Low Pitched Roofs and hot work regulations should be followed as regards working methods and execution of detailing.

## Torch-on bitumen membranes

The use of torch-on products always requires a valid hot work permit and permission. The torch-on method is better suited to high pitched roofs than hot bitumen bonding. Further information on the use of torch-on membranes can be found in the Low Pitched Roofs part of the manual.

## Quality requirements

The following table contains the principle quality requirements for the installation of bitumen roofing, and it is intended to harmonise the practices of the sector and to clarify what can be demanded of the work and how it should be carried out.

Decking	<ul style="list-style-type: none"> <li>• Deck boarding according to truss spacing (Table 11)</li> <li>• The end joints of purlins must rest on roof trusses</li> <li>• Minimum depth of ventilation gap 100 mm</li> <li>• An underlay to be used under bitumen roofing shingles over entire roof area</li> </ul>
Installing bitumen roofing	<ul style="list-style-type: none"> <li>• Roofing nails must extend through the deck boarding</li> <li>• All nailing to be concealed (with the exception of cap strips nailing of bitumen roofing joints over battens)</li> <li>• The overlaps of membranes and roofing shingles are always made in the same direction</li> </ul>
Valleys	<ul style="list-style-type: none"> <li>• A cap membrane should be installed along the base of a valley</li> <li>• At valleys the ends of membranes and bitumen roofing shingles should be bonded carefully over the valley cap sheet</li> </ul>
Penetrations and roof hatches	<ul style="list-style-type: none"> <li>• EPDM rubber sleeves are used in circular penetrations and the cap sheet or shingles are bonded over its flange completely</li> <li>• Chimneys and similar constructions are weatherproofed with cap sheeting (upturn <math>\geq</math> 300 mm), which is anchored mechanically at its top edge</li> <li>• Ducts or other penetrations should not be located at valleys</li> </ul>
Flashings	<ul style="list-style-type: none"> <li>• A drip edge should be installed at eaves and fixed to the decking in a zig-zag pattern at 10 cm spacings (roofing nails or screws). End joints are lapped by approx. 50 mm.</li> <li>• At the verge either a drip edge or an upstand, which is capped with flashing, can be installed</li> <li>• Upturns are generally protected with apron flashing</li> </ul>
Finish and workmanship	<ul style="list-style-type: none"> <li>• The overlap (going) of the shingle should be constant in order to create a regular pattern (diagonal lines must also be straight)</li> </ul>

# Detail Drawings (Bitumen roofing system)

## I. Roofing with triangular upstand battens

- A 1-m-wide underlay is installed first at valleys if applicable.
- A drip edge is installed at eaves over the timber decking, fixing with nails or screws.
- The verge can be detailed in a similar fashion or by executing an upstand detail (e.g. using a triangular batten), in which case the drip edge flashing is installed over the roofing.
- An eaves strip (a strip half the width of a roll) is installed along the eave over the drip edge.
- The triangular battens (50x50) are installed vertically over the roof surface at approx. 67 cm spacings so that the upper end remains approx. 20 cm short of the ridge and the lower end extends 0-5 cm over the eaves strip.
- 70 cm-wide cap sheets are installed between the battens from the ridge down and should overlap the eaves strip by 15 cm. Each sheet is nailed at the ridge and along the sides to the battens. The lower end is glued over the eaves strip.
- 10 cm-wide strips of membrane should be nailed over the upstand battens with ends glued down.
- A strip half a roll in width should be glued over the ridge.

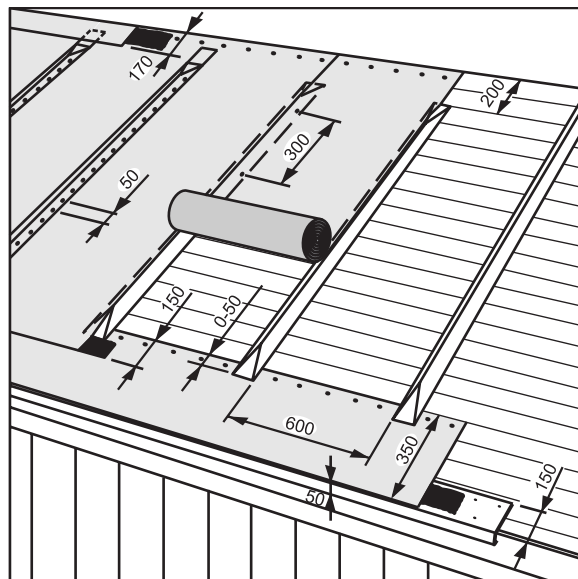

## 2. Roofing system with sealed joints / valley

- A 1-metre-wide underlay is first installed over the valley and it is fixed along the edges with nails at approx. 20 cm spacings.
- The eaves drip edge is installed over the underlay at the valley and in other places over the timber decking, fixing with nails or screws.
- The same drip edge can be used at verges or an upstand verge detail can be constructed.
- A 50 - 70 cm-wide cap sheet is mounted in the valley, nailing along the edges over the underlay and gluing to the drip edge.
- The cap sheets of a roofing system with sealed joints can be installed in horizontal or vertical runs.
- Self-adhesive membranes are fixed to the substrate by blind nailing and the edges are carefully joined together. End joints, penetrations, upturns and other details are executed by gluing them with a bitumen-based, cold application adhesive.
- If the membranes do not have self-adhesive edges they should be nailed to the base and the joints sealed with cold application adhesive or hot applied bitumen.
- The joints of weldable membranes should be heated with a propane torch or a hot air gun (Note! Hot work).

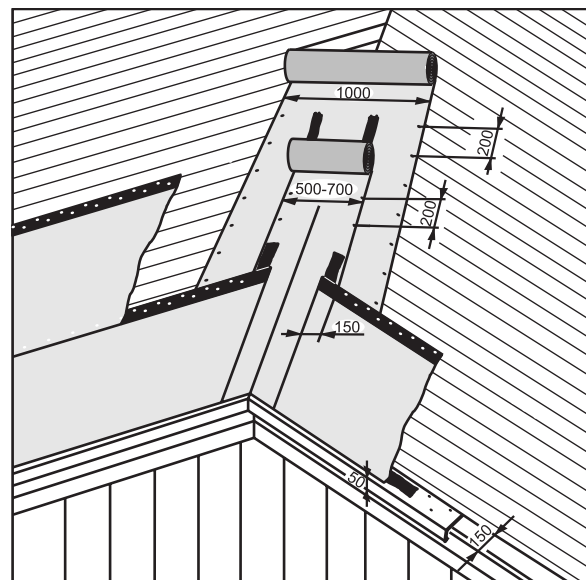

## 3. Roofing system with sealed joints / ridge and chimney abutment

- At chimneys and ventilation outlets cap sheets are extended approx. 10 cm above the upper edge of the outlets.
- The membrane pieces cut for the chimney collar are mounted around the chimney as instructed and the roofing work is then continued up to the ridge.
- A 30 cm-strip is glued over the ridge or else the membranes of the last-mounted roof slope are extended 15 cm over the ridge.

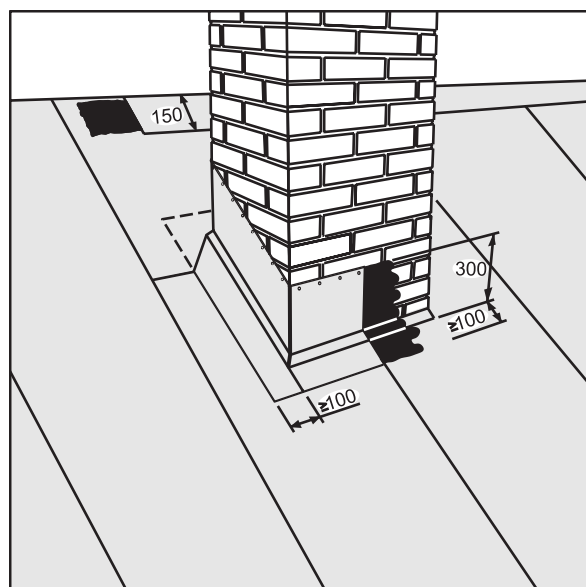



#### 4. Roofing shingles / valley

- A 1-metre-wide underlay is first mounted over the valley and then fixed along the edges with nails at approx. 20 cm spacings. Next, the underlay is installed over the rest of the roof, with the edges overlapping the valley underlay by 150 mm. The runs can be either horizontal or vertical. The underlay joints are overlapped by 10 cm and glued to one another. They are fixed to the deck with blind nailing.
- The eaves drip edge is fixed with nails or screws over the underlay.
- The same drip edge can be used at verges, or an upstand verge detail can be constructed.
- A cap sheet with a minimum width of 70 cm is mounted along the valley and nailed and glued along the edges onto the underlay. It is also glued over the drip edge.
- Roofing shingles are lapped over the above mentioned cap sheet by at least 150 mm and glued to it carefully. Nailing the roofing shingles over the cap sheet is not recommended.
- At the eave, an eaves strip or sheets are installed over the drip edge according to manufacturer's instructions.
- The installation of roofing shingles proceeds from the eaves towards the ridge. Each run of shingles is installed over the previous one according to manufacturer's instructions.

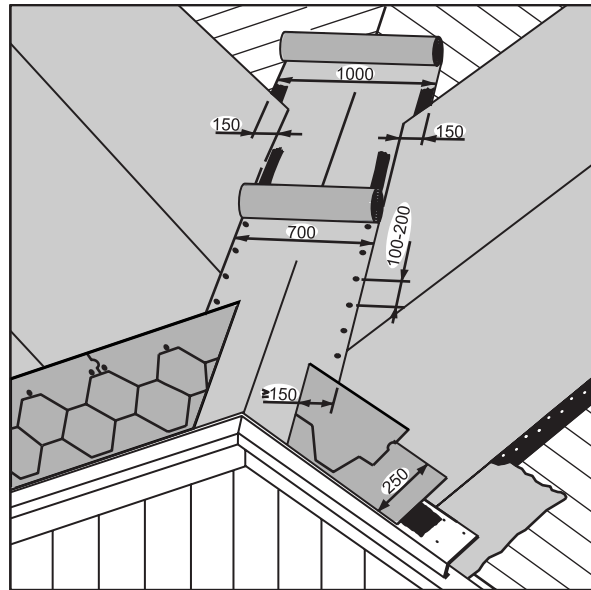

#### 5. Roofing shingles / ridge and chimney abutment

- At chimneys and ventilation outlets roofing shingles are installed to coincide with the upper edge.
- The membrane pieces cut for the chimney collar are mounted around the chimney as instructed and the installation of shingles is continued up to the ridge.
- Roofing shingles are not folded over the ridge; instead the excess is cut off and ridge sheets are installed over the ridge according to manufacturer's instructions.

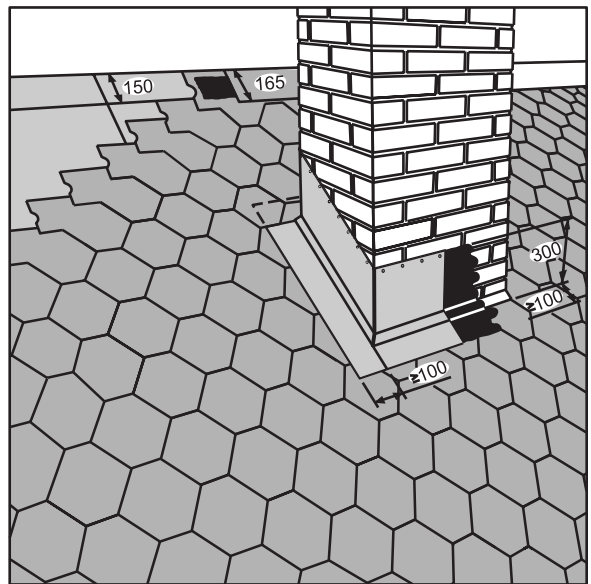

#### 6. Roofing shingles / verge

- At the verge the drip edge is mounted over the underlay by nailing (or screwing).
- The roofing shingles are cut in the direction of the verge and glued to the drip edge to a width of 100 mm.

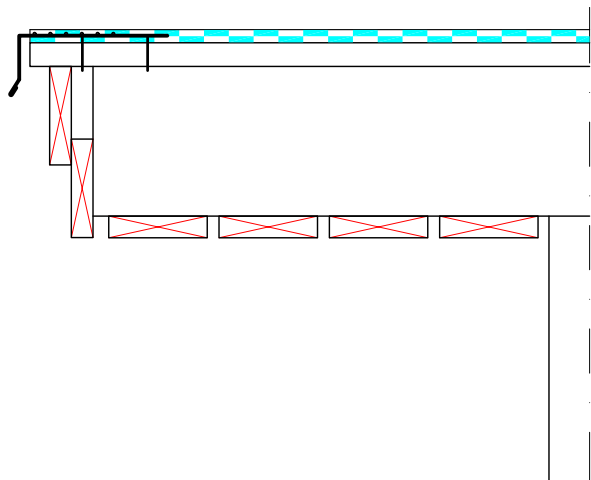

## 7. Roofing shingles / verge upturn detail

- A triangular section batten or a bevelled plank is nailed onto the decking.
- The edge of the underlay is folded over the verge edge under the base of the deck boarding.
- The roofing shingles are cut so that they extend to the upper edge of the upstand batten and glued to the underlay at a width of 100 mm.
- The verge drip edge flashing is mounted on top.

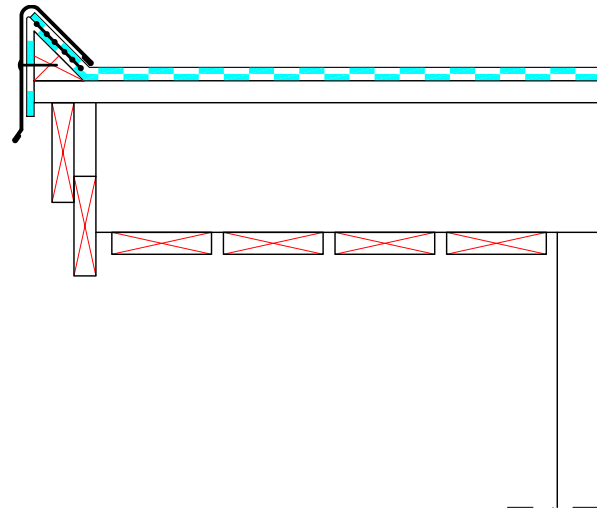

## 8. Upturn detail principle

- The actual roofing (shingles, membrane with upstand battens or roofing with sealed joints) is installed up to the upper edge of the fillet. The membrane pieces cut for the upturn are glued to the abutment to a minimum height of 300 mm and over the roof surface at least to a width of 100 mm. The upper edge is anchored in place mechanically.
- The vertical part of the membrane is protected with a flashing. The weathertightness of the flashing is ensured by mounting a capping board on top of it or by making a groove in the abutment into which the flashing is sealed. The flashing is fixed mechanically to the abutting structure only along the top edge.

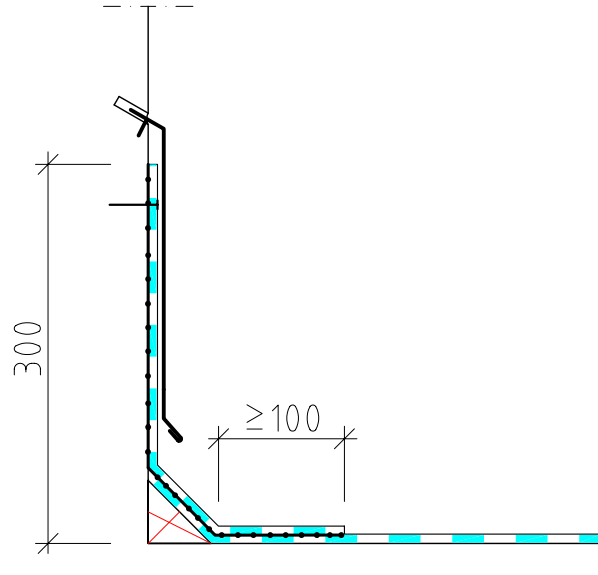



## Sheetmetal roofs

### General

Nowadays sheetmetal roofings are generally manufactured of hot dip galvanized and otherwise coated, light gauge sheet steel. Other materials include aluminium and copper. The advantages of sheetmetal roofing systems include light weight as well as the numerous profile, coating and colour options they offer.

Profiled sheetmetal roofing refers to corrugated, standing seam or pressed sheetmetal roofing. Corrugated and standing seam roofing systems utilise directionally corrugated metal roofing sheets with a regular cross section throughout. Pressed sheetmetal indicates three-dimensionally formed metal roofing panels.

Long strip roofing (with machine welted seams or flat sheetmetal roofing) refers to a roofing system where flat, pre-cut sheets (panels, strips or sheets with side edge upstands) are joined by welting and/or with clips.

An upstand seam roofing system comprises sectionally regular profiled sheets with side edges folded up to form a seam. Seam profiles vary and include self-locking types and others that are joined with different types of clips and fixings. Upstand seam roofing sheets are not welted separately, and they can characteristically be installed without special tools.

### Design

#### General

Due to the strong thermal movement of metal, the roofing has to be designed so that the movement does not damage the roofing itself or any connected structures.

#### Roof pitches

The range of application and minimum pitches for sheetmetal roofing systems are given in Table J1. The roofing manufacturer will provide product specific minimum pitches. The range of application (pitch) is affected by the height of the corrugations, laps, sealing of joints and slope length.

### Roof deck

An underlay that meets the relevant product class requirements should be used with sheetmetal roofing. Its main purpose is to ensure that condensed water on the undersurface of the roofing runs off in a controlled manner outside the perimeter walls.

Long strip roofing makes an exception and can be installed without an underlay on the following conditions:

- the roofing is of a machine welted type with standing, double lock welts sealed with mastic (RT 85-10562)
- the roof pitch is at least 1:7
- the decking consists of hit and miss boarding with 20-60 mm gaps
- the entire roof space is well ventilated.

Table 13  
Underlays for sheetmetal roofing

Sheetmetal roofing	Underlay		Without underlay
	Self-supporting underlay AKV 2 or AKV 1	Underlay installed on decking AKK 2 or AKK 1	
Long strip roofing with welted seams pitch > 1:7	X	X	X
Long strip roofing with welted seams pitch 1:7 - 1:10	-	X	-
Profiled sheetmetal (folded and corrugated roofings)	X	X	-
Sheetmetal roofing with upstand seams	X	X	-



## Ventilation

There must be a ventilation gap of min. 100 mm below the substrate (underlay or board deck) sheetmetal roofing. There should be sufficient replacement air vents at eaves and longitudinal ventilation at ridge. The outlet ventilators should be positioned below the verge at the top part of the gable end or, if needed, ridge ventilators are used (e.g. hipped roofs and roofs between firewalls in terraced houses), or alternatively a ventilated ridge structure is constructed.

## Details

Particular attention should be paid to valleys, hips, eaves, verges, upturns and penetrations.

Penetrations should be made of the same material as the roofing or alternatively plastics or rubber that has the required mechanical strength and good weather resistance. Sleeves and lead-through installations designed to suit different roofing systems are available. These include roof hatches, sleeves for drain stack pipes, lead-through components for ventilation systems and mechanical ventilators, sleeves for aerials and suction ventilators. The lapping, sealing and fixing of these should be carried out according to manufacturer's instructions.

Penetrations should be positioned as close as possible to the ridge so that the penetrations are not subjected to unnecessarily heavy loads due to sliding snow.

## Coatings

Today ready-coated light gauge steel sheets with a 275 g/m<sup>2</sup> coating of zinc below the coating are generally used. Alongside these, hot dip galvanized sheetmetal (min. thickness of zinc coating 350 g/m<sup>2</sup>), which receives its final coating on-site, is used. Coatings consist of various roofing paints and bitumen based compounds.

Other sheetmetal types (e.g. copper or aluminium) have better weather and corrosion resistance and need no additional coating.

Below are described some properties of paints used in ready-coated steel sheetmetal roofing products:

**Pural** is a polyurethane paint that forms a relatively thick coating and has good weather and corrosion resistance. It is also suitable for welted roofing products.

**Matt polyester** is a paint that differs from other coatings in its matt finish. It has good weather and corrosion resistance. Sheetmetal products should

be handled with care due to the thinness of the coating. Matt polyester is mainly used in profiled roofings and is not recommended for long strip roofing.

**PVDF (PVF2)** e.g. polyvinylidene fluoride is a paint intended for high end applications, mainly for facade structures. PVDF has excellent resistance to UV radiation. PVDF coating may be bent without brittling in almost all conditions and is therefore also suitable for seamed products. PVDF is a thin coating, so careful handling is essential to avoid scratching.

**Mineral coated steel roofing** has a coating where natural stone granules are bonded to a hot dip galvanised, primed, pressed sheetmetal with acrylic paste and acrylic varnish. The advantages of the coating include good weather resistance and low noise, and it can be worked with normal sheetmetal tools.

Pural and PVDF coatings are recommended for long strip roofing (scores and scratches to be protected). Pural is recommended for pressed panels and corrugated roofings.



# Profiled sheetmetal roofs

## General

The minimum pitch for corrugated roofing systems is 1:10 and usually for pressed sheetmetal systems 1:5. The minimum pitch given by the manufacturer for different products must be noted. The table below presents the minimum pitches for different profile depths with regard to sidelaps and sealing method of seams.

## Substructure

Timber purlins (usually 32 x 100 mm) are generally used under sheetmetal roofing. The purlins are fixed to each roof truss with two fixings. Steel purlins with holes for improved ventilation may also be used.

## Fixings

Today drill-point roofing screws with gaskets are used almost without exception for fixing profiled roofings. Their pullout strength compared with e.g. ribbed nails is almost double.

The long-term durability of roofing screws must be at least equal to that of the roofing itself. Overlap screws should have a short threadless part that prevents overtightening. The minimum diameter of a washer (stainless steel or aluminium) is 14 mm and a weather resistant EPDM rubber ring should be vulcanised to it. The screw heads should bear the manufacturer's marking. The roofing manufacturer's instructions should always be followed in installation.

















## Implementation

### Dimensions

Generally the supplier of the material provides the roofing components to measure, according to the dimensions provided by the client. A rule of thumb is that the length of a roofing sheet is measured from the outer surface of the fascia board to the middle line of the ridge. In mansard roofs the effect of the hip and the profile depth on

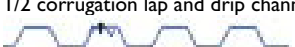
Table 14

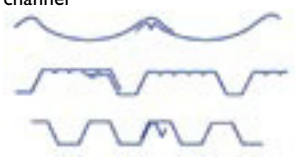
**The minimum pitches for profiled sheetmetal roofing systems with varying profile depth.**

Roof pitch	Corrugation depth mm	Lapping method
Steeper than 1:10 	$h > 50$ 	1/2 corrugation lap and sealant 
	$30 < h < 50$ 	1 1/2 corrugation lap and sealant 
		drip channel and sealant 
Steeper than 1:7 	$h < 18$ 	drip channel and sealant 
		1 1/2 corrugation lap and sealant 
Steeper than 1:5 	$h < 18$ 	1/2 corrugation lap and sealant 
		1/2 corrugation lap and drip channel 
Steeper than 1:5 	Pressed or corrugated sheet	1/2 corrugation lap and capillary or drip channel 
		1 1/2 corrugation lap 

the length of the sheet for the upper slope should be allowed for. In the dimensions it should be ensured that the lower edges of the sheets form an even drip edge along the entire eave. Valleys, hips and penetrations are to be taken into account in the dimensioning of the sheets, and at these details adjustments will have to be made to the roofing sheets on-site.

Before installing a profiled sheetmetal roofing you should make sure that the components of the roof structure are straight and that the corners of the slopes are rectangular. Deviations of over 30 mm in the diagonal measurements of a roof have to be rectified.

In the case of deviations less than 30 mm it is usually enough to straighten the eave, but in the case of greater discrepancies the verges have to be straightened.

### Installing the underlay

Self-supporting underlays are usually installed horizontally over the roof trusses and are fixed with clips or wide-headed roofing nails. The overlap at the sides and ends should be at least 150 mm. The underlay should not be tightened too much; the manufacturer's instructions should be followed. End joints should coincide with the roof trusses. At least 30 mm battens should



be installed on top of the underlay along the trusses to create a ventilation gap.

If the penetrations are wider than 400 mm it is recommended that reverse falls be built above it to direct rainwater away and, if needed, water guide strips over the underlay to direct water that may have passed through around the penetration. For this reason penetrations should always be installed during the roofing work, not retrofitted. Tubular penetrations are sealed with special lead-through fittings.

### Installation of purlins

In profiled sheetmetal roofs, purlins should be installed from the eave up. The purlin spacing is chosen according to the installation instructions. With pressed sheetmetal roofing the lowest purlin should be thicker than the rest, as the last purlin spacing is shorter than the others.

### Installation of barge boards

When using pressed sheetmetal roofing the outer barge board is elevated or its height is increased with a batten above the level of the purlins by as much as the depth of the profiled

sheet. The verge trims are fixed to the barge board.

### Valley

The decking for the valley sheet consists of hit and miss boarding with approx. 20 mm gaps and its width should be equal to the sheet (approx. 0.5 m on both slopes) and a wider gap (approx. 50 – 80 mm) in the boarding is left at the base of the valley. The boarding should be level with the purlins. The end joints of valley sheets should be overlapped by at least 200 mm. In roofs with a lower pitch than 1:4 sealing the end laps with butyl based mastic is recommended. The metal sheet is fixed initially along the outer edges and finally with the roofing sheets. The bottom of the valley sheet is formed to the shape of the valley. The valley sheet should reach at least 250 mm under the roofing sheets. A min. 200 mm section of the valley sheet should be left exposed between the roofing sheets. A suitable sealing strip should be installed between the valley and roofing sheets. The valley underlay is installed longitudinally over the valley boarding (ventilation battens are then fixed on top) and the underlay for the slope is laid on top of it. A valley that terminates at a slope is constructed according to installation instructions.

### Installation of profiled sheetmetal roofing

Install a drip edge before the profiled roofing sheets. Profiled sheetmetal roofing is fixed according to type and shape according to the manufacturer's instructions. Most commonly it is done with roofing screws with gaskets, from the bottom of the profile or pressed sheet groove. At the eave the roofing sheets should extend 30 – 50 mm over the edge to form a drip. The sheets should be interconnected at sidelaps with screws and pressed sheets below each crosswise pattern on top of the undulation. If needed, the side or end laps may be sealed, or the same effect may be achieved by increasing the overlap. The sheets should be aligned according to the eaves line.

The installation instructions take into account suctional forces due to wind affecting the edge areas, the effect of thermal movement in the central area, the weathertightness of the joints and the appearance of the joints. The screws along the slopes should be fixed according to the installation instructions.

The ends of corrugated sheets should overlap by at least 200 mm and pressed panels by at least 130 mm



depending on the pattern. Corrugated roof sheet end joints are fixed at every corrugation and pressed panels at every other one. The end joints of sheets specifically designed to lap over one another vertically have product-specific end joints.

Sheetmetal roofings can be worked with a hand-held circular saw (the blade must be suitable for cutting sheetmetal), sheetmetal shears, a nibbler or a jigsaw. An angle grinder should not be used. The roofing sheets should be protected from sharp chips to protect the coating from damage. All drilling and cutting debris must be carefully removed from the roofing sheets. Paint-coated sheetmetal should be handled with care when installing or transporting to avoid scratches. Any scratches and cut edges must be touched up after installation.

### Flashings (upturns)

Flashings should reach at least 300 mm above the roof surface. In a longitudinal upstand the flashing must extend at least over the first full corrugation and at a crosswise junction at least 100 mm over the roofing sheet. The lengths of the flashing strips vary between manufacturers. The minimum overlap of the strips is 100 mm. The strips are fixed to the roofing at 300-800 centres at longitudinal abutments and at crosswise abutments at approx. 400 mm centres. The joints may be sealed if necessary.

### Verge trim

The verge trim should extend over the first corrugation head. The verge trim is usually fixed to the barge board along one side and from the top to the roofing sheet according to the manufacturer's instructions. Verge trims usually come in 3 m lengths, but this can vary between manufacturers. The trims should be installed from the eave up and any excess at the ridge is cut off. The verge trims should be lapped by 50–100 mm. It is not recommended to fix the trims to one another.

### Ridge capping (ridge and hips)

The ridge should be capped with a ridge strip recommended by the manufacturer. Their lengths vary between manufacturers, and the lap is generally 100 mm. Profiled closer units or vented hip closers should be installed between the ridge cap and the roofing sheets. The ridge capping should be fixed to the corrugation heads at approx. 400 mm intervals. It is not recommended to fix the capping units to one another.

### Installation of roof access hatch

The firefighting roof hatch should be mounted as close as possible to the ridge, completely over the roofing sheets. The surface of the access hatch should be capped with sheetmetal and its upper edge folded under the ridge

capping. It should be attached to the roofing with drill tip screws.

### Weatherproofing of penetrations

The use of a sleeve unit with a flashing plate matching the shape of the profile is recommended. In refurbishment projects a type with a general, mouldable flashing plate may also be used. All penetration sleeves and rooftop ventilators include an underlay sleeve unit. Penetrations should be installed as close as possible to the ridge or walkways. If penetrations are at risk of being damaged by slipping snow or ice, they should be protected with snow barriers. Usually penetration sleeve units contain an accordion-type adjuster piece e.g. to fit a drain ventilation stack pipe.

### Chimney flashing

A chimney may be built before the installation of roofing sheets or afterwards, by making a cutout in the roofing. If the chimney is constructed afterwards the roofing sheets have to be protected well all the way down to eave for the duration of the work. The chimney abutment should be protected with flashing, or alternatively it can be encased with sheetmetal, after which the upper end sheetmetal apron is mounted over the upturn and continued under the ridge capping.





## Long strip roofing with welted seams

### General

Long strip roofing is also called machine-welting roofing or flat sheet-metal roofing.

Long strip roofing with double lock seams may be used on roofs with a minimum pitch of 1:10. In demanding roofing applications thicker or narrower sheets may be used.

It must be ensured that the sheetmetal is suitable for the application and that it is of a quality intended for welting roofing. The sheets used must be sufficiently flat, i.e. they must not buckle along the middle. The guideline of the Finnish Building Information File (RT) sets the limit of how much the centre may rise above the decking at one hundredth of the run width.

The layout of the metal roofing has to be designed so that thermal movement does not damage the roofing itself or any connected elements or component parts.

The RT file 85-10562 provides detailed information on flat sheetmetal roofing.

### Roof deck

The minimum thickness of the deck boarding is 20 mm. The gaps between the boards on very low pitched roofs should be 20 mm and on steep slopes max. 60 mm. The eaves, ridges, valleys and hips as well as areas coinciding with penetrations, walkways and snow barriers should always be close boarded. At valleys and sizeable penetrations, a bitumen membrane should also be installed over the close boarding.

Special attention should be paid to the ventilation of the underlying space, as

the deck boarding will absorb some condensed moisture and needs to dry sufficiently to avoid rot damage.

The entire deck may be close boarded, which is recommended in particularly demanding roofs and those with a pitch lower than 1:7. With a close boarded deck it is recommended that a bitumen membrane be used with flat sheet roofing directly on top of it. The above system improves the sound insulation of the roof, and the bitumen underlay protects the structure from condensation and leaks while also providing work time protection before the roofing is installed.

If a self-supporting underlay is used, 50–75 mm furring strips should be installed over the underlay to ensure good ventilation. The actual decking (hit and miss boarding) is mounted on the furring pieces. The underlay should extend sufficiently at the eave, and boards are mounted on the soffit for a neat appearance. In such a system it is especially important to ensure that ventilation also functions well between the underlay and the sheetmetal, and that water can run off the underlay in a controlled manner.

### Sheetmetal strips, seams and fixing.

On long strip roofing all the welts should be double-locking and they are sealed with a sealing compound, or alternatively with appropriate joint paint.

Steel roofing is generally mounted with rigid fasteners. Copper, aluminium and stainless steel roofing is mounted partly with fixed and partly slide-in fasteners. It is preferable to screw in the fasteners to the timber base at joints. When using nails, make sure that the nails cannot lift and damage

the roofing. The wind conditions of the site must be taken into account when specifying the roof fixings. The fasteners, i.e. clamps are installed at max. intervals of 400 mm.

The max. length of sheet steel roofing is 10 m. In longer strips an expansion joint needs to be incorporated.

At eaves an eaves sheet nailed to the roof decking should be installed. The sheet should extend 30–50 mm over the eave to form a drip.

### Curb gutters and penetrations

Usually water is channelled into downpipes with exterior gutters. A curb gutter can be used to direct the flow of water on the roof, and the water is expelled directly into the downpipe funnel. The minimum slope of a curb gutter is 1:75. To ensure weathertightness, a metal sheet or a bitumen membrane is installed under the curb and should extend from underneath the seam to the eave. The scupper detail is connected to curb gutter with double-lock seams.

The functioning of the base flashing around penetrations requires double-lock seams. They should be executed in accordance with the RT file guidelines. Seaming of the penetration to roofing panels with a single-locking seam is insufficient.

### Upturns

At abutments the upturn strip should extend at least 300 mm up the vertical surface. At a sheetmetal abutment the upturn is joined with the vertical sheetmetal at a min. height of 150 mm. The seams of the upturn pieces should be double-locking.

## Quality requirements: Pressed panels and corrugated roofings

Roof structure under sheetmetal roofing	<ul style="list-style-type: none"> <li>• Pressed and corrugated roofings must be installed on a stable metal or timber support structure.</li> <li>• The support or purlin spacing is specified according to roof loading and the applied sheet type according to manufacturer's instructions.</li> <li>• The underside of the roofing must be completely ventilated (ventilation gap min. 100 mm)</li> <li>• The underlay must be installed so that water running down the underlay cannot seep into the roof structure from the underlay joints.</li> <li>• The minimum lap of the underlay joints is 150 mm.</li> <li>• At the eave and verge the underlay should extend at least 200 mm over the wall line</li> <li>• Additional purlins should be installed at eaves, under snow barriers and walkways if necessary.</li> <li>• The underlay must meet the applicable product class requirements.</li> </ul>
Installation of sheetmetal roofing	<ul style="list-style-type: none"> <li>• The roofing sheets are to be installed in the order advised by the manufacturer.</li> <li>• The roofing sheets should be installed perpendicular to the eave so that they do not start to deviate from the vertical direction</li> <li>• The roofing sheets should be fixed to the purlins according to manufacturer's and RT file instructions</li> <li>• There must be an adequately stable supporting structure under the end laps</li> <li>• At the eave the roofing sheets should extend 30–50 mm over the edge</li> <li>• The corrosion resistance of the fasteners must be at least equal to that of the roofing and the connected accessories</li> </ul>
Valleys	<ul style="list-style-type: none"> <li>• The boarding at the base of the valley should be dense, with approx. 20 mm gaps.</li> <li>• The valley sheet must extend at least 250 mm below the roofing sheets.</li> <li>• The joint between the valley sheet and the roofing strips can be sealed, e.g. with profiled closers.</li> <li>• The recommended minimum width of a valley is 1000 mm</li> <li>• The lower ends of the roofing strips meeting the valley should be fixed at equal spacings, with at least two screws</li> </ul>
Penetrations, roof hatches and snow barriers	<ul style="list-style-type: none"> <li>• Penetration accessories should be purpose-made for sheetmetal roofs and they must be installed according to manufacturer's instructions.</li> <li>• The penetration accessories must equal the life span of the roof in terms of their strength, frost resistance, UV resistance and weathertightness with conventional maintenance measures</li> <li>• Particular attention should always be paid to the weathertightness of penetrations in pressed panel corrugated sheetmetal roofs and especially to the underlay joint</li> <li>• Penetrations should be situated as close to the ridge as possible and never in valleys</li> <li>• Falls in the reverse direction to the roof should always be built behind wide penetrations (over 400 mm) to divert rainwater away.</li> <li>• Snow barriers should be secured well to the roof structure, e.g. according to the guidelines of the RT file</li> </ul>
Trims	<ul style="list-style-type: none"> <li>• Trims are usually made of the same material as the roofing</li> <li>• The min. gauge of the trims is 0.5 mm</li> <li>• At the eave a drip edge is used to channel water away from the building fabric or into the rainwater gutter</li> <li>• Verge trims should extend over the last roofing strip beyond a standing seam, fold or a corrugation head, depending on the roofing type</li> <li>• The end laps of eave and verge trims should be at least 50–100 mm</li> </ul>
Finished work	<ul style="list-style-type: none"> <li>• The roofing must be watertight and installed according to the guidelines of the current RT file</li> <li>• The surface of the roofing must be undamaged and clean upon completion Any scratches on painted sheetmetal roofing should be touched up.</li> </ul>



## Quality requirements of long strip sheetmetal roofing

Roof structure under sheetmetal roofing	<ul style="list-style-type: none"> <li>• The roof decking for long strip roofing with welted seams should be built of min 20 mm, air dried and square edged timber.</li> <li>• The underside of the roof decking must be fully ventilated.</li> <li>• The use of old boards or heat treated wood is not acceptable.</li> <li>• Over the slopes the gaps between the boards should be 20–60 mm, except in the areas that are close boarded (valleys, hips, ridge, around major penetrations)</li> <li>• Any dirt or spillage must be removed from the decking prior to installing the roofing</li> </ul>
Installation of sheetmetal roofing	<ul style="list-style-type: none"> <li>• Roofing is generally mounted with rigid fasteners. The max. recommended strip length is 10 m. On long slopes (over 10 m) it is recommended to use max. 6 m strips joined together at the ends with a sealing system that allows thermal movement</li> <li>• The fasteners should be made of the same material as the roofing. The screws or nails used to attach the fasteners must be at least as corrosion resistant as the roofing.</li> <li>• The fastener spacing must comply with the valid RT file guidelines</li> <li>• The strips are joined together with double-lock upstand, welted or dressed down welted seams treated with a sealing compound.</li> <li>• Sealing compounds that retain their elasticity, and do not brittle or run are suitable. No breaks are allowed in the seal of a welted seam</li> <li>• At eave, upstand seams should be dressed down and the drip edge should extend 30...50 mm from the vertical surface (fascia).</li> <li>• The metal roofing sheet is always terminated with a fold, which should be positioned and directed so that water is not directed on to or absorbed into the element that is being protected</li> <li>• A min. of 300 mm upstand is made at the abutment of sheetmetal roofing and an adjoining wall without sheetmetal protection</li> <li>• An upstand against a surface that has no sheetmetal covering should be fastened, and if needed, sealed according to the structural engineer's instructions</li> </ul>
Valleys	<ul style="list-style-type: none"> <li>• The sheetmetal valley strip should be joined to the ridge and eaves as for adjacent strips</li> <li>• The valley strip should extend at least 250 mm over the adjacent slopes and it is seamed with upstand double-lock welts and secured with sealing compound</li> <li>• At long valleys (over 10 m), extension joints should be made at approx. 6-metre intervals</li> </ul>
Penetrations and roof hatches	<ul style="list-style-type: none"> <li>• The removal of water from the slope above protruding parts, e.g. chimneys, is ensured by means of a saddle that has falls to one side or in both directions</li> <li>• It is recommended that chimneys be encased in sheetmetal up to the base of the concrete capping</li> <li>• The minimum size of a roof hatch is 600 mm x 600 mm and its skirting and cover should be protected with sheetmetal</li> <li>• The roof hatch must be situated according to current fire safety regulations and the guidelines of local fire authorities</li> <li>• A conical sleeve with a min. height of 300 mm should be installed around pipes, upright supports, aerial bases and similar fittings. A watertight seam should be made between the sleeve and the roofing strip or a flashing unit that is attached to the roofing</li> </ul>
Finished work	<ul style="list-style-type: none"> <li>• A roof must be weatherproof and the seams should be made according to the current RT file guidelines</li> <li>• The contractor is responsible for the watertightness of the roof</li> <li>• The sheet strips should be sufficiently flat. In the middle of each strip the strip should not rise above the deck by more than one hundredth part of its width</li> <li>• The surface of the roofing should be clean at completion. Any scratches on painted sheetmetal should be touched up</li> </ul>

# Detail Drawings (Sheetmetal roofs)

## 1. Eaves

- Sarking installed over the roof trusses should extend at least 200 mm beyond the wall perimeter.
- The purlins installed over counter battens ( $\geq 30$  mm) are specified according to the roofing material.
- The profiled sheets should extend 30 – 50 mm beyond the fascia board.
- The outer edge of an eaves gutter must be at least 25 mm below the roofing surface measured from the trough of the profile.

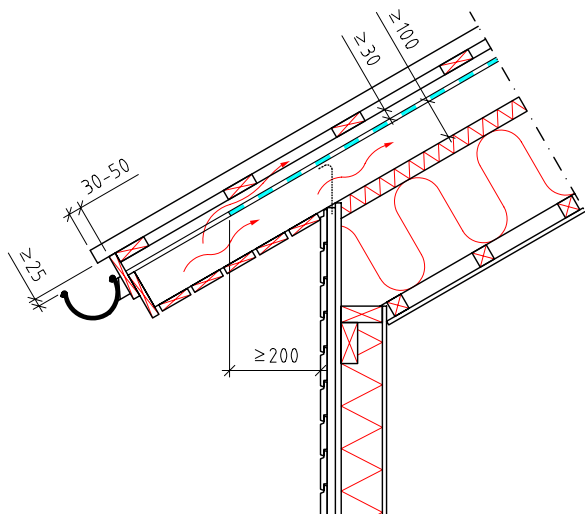

## 2. Verges

- Sarking installed over the roof trusses should extend at least 200 mm beyond the wall perimeter.
- At the gable end, ventilation of the roof space can be arranged by vents placed as high as possible (as in the illustration) or through the eave (vent gap between wall and sarking  $\geq 30$  mm). If needed, a stopper strip can be installed at the top edge of the wall.
- The gable end ventilation can be replaced by ridge vents (suction ventilators).

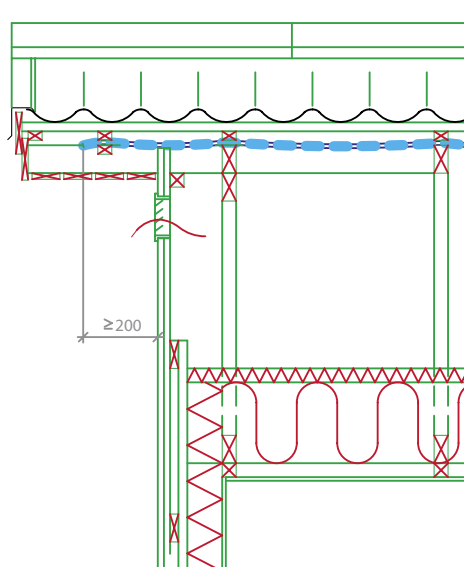

## 3. Ridge

- A minimum 100 mm gap should be left between the sarking and the ridge. Above it, on top of the counter battens, a wider, gapless decking is constructed, and a strip of sarking is laid over it, passing over the ridge and overlapping the slope sarking by at least 100 mm.
- Caulking is installed between the ridge cap and the profiled sheets.
- Alternatively the ridge can be detailed so that the sarking is lapped over the ridge (Fig. 7, p. 60). In this case the ventilation of the space above the sarking is arranged with suction vents at the ends of the ridge and/or along the ridge.

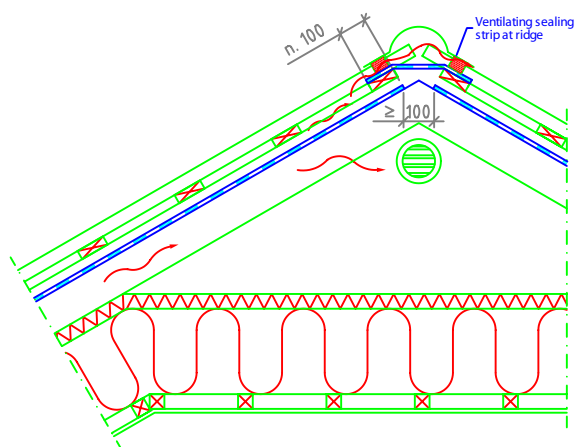

#### 4. Valley

- The valley can be executed with gapless decking at the base of the valley or as shown here without the decking.
- Sarking is installed along the base of the valley (min. width 1 m), and the sarking of the slopes are lapped over it.
- The ends of the counter battens are left 25-40 mm short of the valley base (ventilation gap along the valley).
- A decking with 20 mm gaps is constructed over the counter battens for a strip of sheetmetal to be laid along the valley.
- The valley sheet (min. width 1000 mm) is overlapped by at least 250 mm with the profiled sheetmetal roofing.
- A minimum 200 mm valley gutter is left between the roofing sheets.
- Caulking is applied between the valley sheet and the lower ends of the profiled roofing sheets.

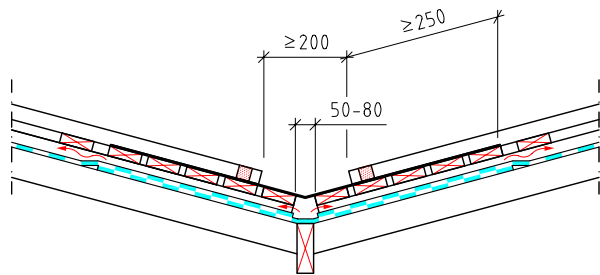

#### 5. Upturns

- At the top end of the slope the sarking is turned up to extend at least 300 mm above the top surface of the roofing to allow ventilation of the space underneath the sarking via a gap incorporated in the detail.
- The upturn flashing should overlap the roofing sheets by at least 100 mm and the gaps between them must be sealed. The apron flashing should be mounted so as to allow ventilation of the space above the sarking.

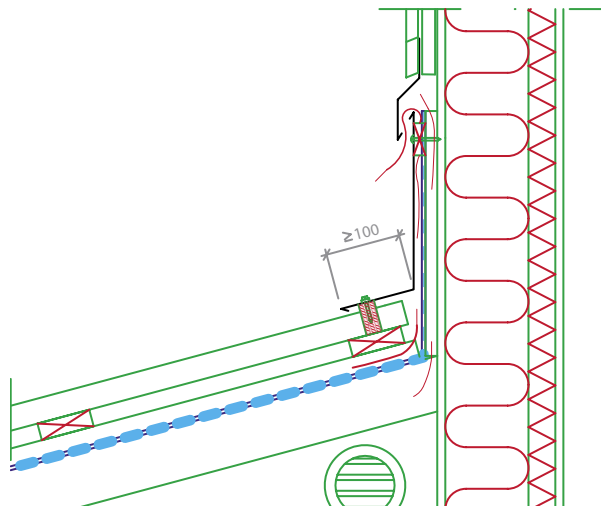

#### 6. Wall abutment

- At the side of the slope the sarking is turned up to extend at least 300 mm above the top surface of roofing.
- The upturn flashing should extend at least over the second peak and the joint with the wall should be sealed above the top edge of the sarking.

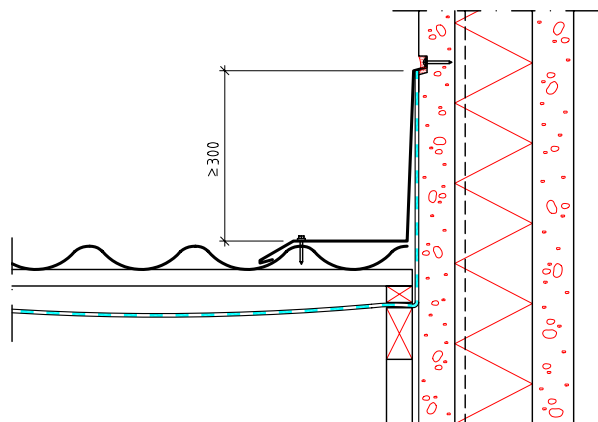



## 7. and 8. Chimney abutment flashing

- At chimney, flue and other abutments the sarking is turned up against the abutting component (approx. 300 mm).
- The chimney flashing min. overlap at the lower end is 100 mm and along the side the flashing must extend over the peak of the profiled sheet (a support can be built underneath if necessary). If the chimney is close to the ridge, the flashing should extend underneath the ridge cap.
- If the chimney is not near the ridge, a separate guide made of sarking should be arranged above the chimney to direct the flow of water. In such a case the chimney flashing here shown to pass under the ridge cap is left below the profiled roofing sheets.
- The chimney flashing may extend all the way up to the chimney, as shown here, or a weathertight joint may be made at least 300 mm above the roofing.

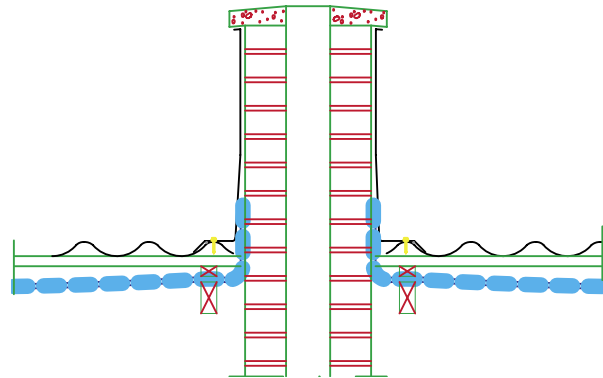
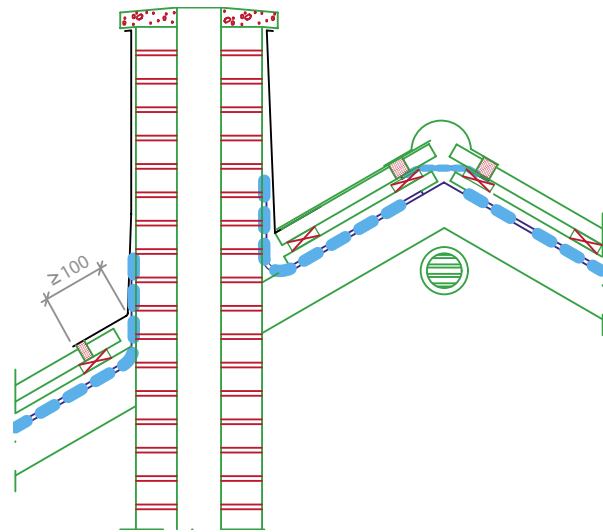









# Tiled roofs

## Fired clay tile roofing

Roofing tiles have traditionally been made of fired clay. Clay tiles get their reddish colour during firing when the iron in the clay oxidises into iron oxide. The surface of clay tiles may also be glazed to give them other colours apart from the typical red. Clay tiles must comply with the quality requirements of European Standards EN 538, EN 539, EN 1024 and EN 1304. Fired clay tiles are either of interlocking or non-interlocking type (i.e. extruded).

## Concrete tile roofing

Today most tiled roofs in Finland are made with concrete tiles. Thanks to the method of manufacture they are dimensionally more accurate than clay tiles. Concrete tiles must comply with the quality requirements of European Standards EN 490 and EN 491. Concrete tiles are usually of interlocking type.

## Design

### Roof pitch

Concrete tile roofing is suitable for all roof shapes up to a minimum slope of 1:5. With clay tiles the minimum pitch is approx. 1:3 depending on type. The minimum pitch of interlocking type clay tiles is 1:4. Product-specific pitch limits given by the manufacturer should be followed.

### Supporting structure

The actual ventilation channel of the roof structure is between the insulation and the underlay.

An underlay should always be installed under roof tiling independent of its pitch, as in changing weather conditions water and snow will enter through connections and joints underneath the roofing.

### Underlay for concrete tile roofing:

A self-supporting underlay that complies with the product class requirements can be used with concrete tile roofing up to a pitch of 1:4; in lower roofs, an underlay membrane with a min. class requirement of AKK 2 (TL 4) laid on solid decking should be used. The minimum pitch for concrete roof tiles is 1:5.

In roofs with a complex geometry or in extreme conditions the underlay should always be a membrane installed over solid board decking.

### Underlay for clay tile roofing:

When using non-interlocking type tiles i.e. extruded tiles, an underlay membrane on continuous board decking should be used independent of roof pitch. The minimum roof pitch for non-interlocking type clay tiles is 1:3. When using interlocking type clay tiles a self supporting underlay complying with product class requirements is acceptable when the roof pitch is 1:3 or over. If the roof pitch is less than



1:3, an underlay membrane with a min. class requirement of AKK 2 (TL 4) laid on solid decking should be used. The minimum pitch for interlocking type clay tiles is 1:4.

In roofs with a complex geometry or in extreme conditions the underlay should always be a membrane installed over solid board decking.

Table 15  
**Underlay for tile roofing**

Tile roofing system	Underlay	
	Self-supporting underlay AKV 2 or AKV 1	Underlay installed on continuous decking AKK 2 or AKK 1*
Concrete roofing tile - pitch $\geq$ 1:4 (1:4 or steeper)	X	X
Concrete roofing tile - pitch < 1:4 (less than 1:4) - very windy location - building with complex geometry Minimum pitch 1:5	-	X
Clay roofing tile, non interlocking - pitch > 1:3 (steeper than 1:3) - building with complex geometry - very windy location	-	X
Clay roofing tile, interlocking type - pitch $\geq$ 1:3 (1:3 or steeper)	X	X
Clay roofing tile, interlocking type - pitch < 1:3 (less than 1:3) - building with complex geometry - very windy location Minimum pitch 1:4	-	X

\* Recommended at valleys

## Loadbearing structure

When specifying the loadbearing frame (rafters, trusses and purlins) of a roof, the weight of the roofing should be noted. The weight used in calculations for concrete roof tiles is approx. 40–45 kg/m<sup>2</sup>. The weight of clay tiles has to be checked with the manufacturer.



## Execution

### Installation of tiled roof

The manufacturer's installation instructions should always be complied with. These installation instructions may in part be applied when using clay tiles, but when using these, detailed instructions should always be acquired from the manufacturer or retailer.

#### Installing the underlay

Self-supporting underlays are usually installed horizontally over the roof trusses and are fixed with clips or wide-headed roofing nails. The overlap at the horizontal and vertical joints should be at least 150 mm. The underlay should not be tightened too much; the manufacturer's instructions are to be followed. End joints should coincide with the roof trusses. Battens (e.g. 22x50 mm) should be installed on top of the underlay along the trusses to create a ventilation gap.

It is recommended to make special water diverters in the underlay above penetrations to divert water past the penetration. For this reason penetrations should always be installed during the roofing work, not retrofitted. Tubular penetrations are sealed with special lead-through fittings for underlays.

#### Installation of tile battens

The distance between the first batten and the ridge board should be 25 – 40 mm, depending on the roof pitch and may not exceed the length required by the nibs at the tile head. The distance between the edge of the eave and the top of the second batten varies among different manufacturers. The remaining slope is divided at equal batten

Table 16

Max. roof truss spacing c-to-c	1 200 mm	900 mm	600 mm
Recommended sizes of tiling battens	50x75 mm	50x50 mm	22x100 mm

Table 17

*Overlaps, effective lengths and widths, average quantities per m<sup>2</sup> for different roof pitches (pitched roof):*

Min. pitch	Min. overlap	Effective length	Effective width avg.	Pcs/m <sup>2</sup>
1:5	100	320 mm	300 mm	10,9
1:4	75	345 mm	300 mm	10,2
1:3 or steeper	50	370 mm	300 mm	9,5

*quantity of ridge tiles approx. 3.0 pcs/m*

spacings so that the c-to-c distance is 320 – 370 mm, depending on the roof pitch. The spacing of the battens should be equal throughout the slope and it should not be changed along the run of the slope. The batten ends should only be cut when the first course of tiles has been installed.

#### Installation of roof tiles

To monitor the straightness of the tile rows during installation, vertical lines should be marked on the tile battens, e.g. at 900 mm intervals. The first row is laid along the eave and the verge lengths are checked. Equal verge lengths can be achieved by moving the first tile row.

To facilitate the laying of the tiles, the roof width should be such that each row can be terminated at full or half tile. The number of vertical rows can be calculated by dividing the ridge length by the effective width of the tile, e.g. 15,000 mm by 300 mm, i.e. 50 vertical rows.

After this, the tiles of the first row are fixed with roofing tile nails, length 75 mm (see. paragraph "Nailing"). The rest of the tiles are laid starting from the right hand corner (viewed from the

ground) towards the left, advancing diagonally towards the ridge.

#### Nailing

Roof tiles are fastened with corrosion resistant nails. The laying of tiles is started from the eaves and verges by nailing the outermost rows at each end. After this, the tiles at valleys and hips should be nailed, as well as those around penetrations if necessary. Ridge capping tiles are either nailed or fastened with clips. If the roof pitch is >1:1, every sixth row is nailed down so that nail rows run diagonally. If the roof pitch is over 60 degrees, all tiles should be fastened. All cut tiles must be nailed, too. In addition to roof pitch, the need for nailing the tiles down also depends on wind exposure.

#### Details

##### Eave

The lowest tile batten should be raised so that the lowest tile is at the same angle as the others. The batten dimensions depend on the tile overlap and roof pitch. A drip edge is recommended at eaves to prevent water running onto the fascia board. The drip edge should be fastened

between the last row of tiles and the last raised purlin. The lowest tile row should extend approx. 45 mm over the fascia board.

### Verge



The verge may be terminated using special verge tiles or a sheetmetal trim. When the first row of tiles is laid it is ensured that each verge is of equal length. When using verge tiles, the upper edge of the barge board must be aligned with the lowest point of the upper side of the tiles. The lowest verge tile should be cut short from the head, so that it only rests on the lowest tile row. When using a sheetmetal verge trim, the upper edge of the barge board should be aligned with the highest point of the upper side of the tiles.

### Valley



A sheetmetal valley strip should be used, or the junction can be boarded at a min. distance of 300 mm from the valley. The surface of the boards must be level with the roof trusses. After this the underlay, or preferably a membrane (TL4), is installed along the entire length of the valley. The actual underlay is installed on top and then the ventilation gap battens.

Vertical battens are fastened to the vent gap battens along the edges of the valley sheet or boarding as dictated by the width of the valley, and their upper surface should be level with the purlins.

After the battens are fastened the sheetmetal panels should be installed, starting from the base of the valley. The edges of the sheets are nailed to the battens that are parallel to the valley. The metal sheets should be overlapped by approx. 200 mm. Sealant may be applied to the joints.

The roof tiles are to be cut in the direction of the valley according to installation instructions.

### Hip



The underlay should be carried over the hip by at least 150 mm in both directions. The next step is to install the battens for the ventilation gap and the purlins. The tiles for one side of the hip should be laid first to be marked for cutting. When marking the line, the space required by the hip board should be allowed for. The tiles are cut as close as possible to the edge of the hip board. The hip board should be fastened over the purlins and its height should be such that the hip tiles can be fastened to it and touch the top of the adjacent tiles. It is recommended to use a ventilated hip closer below the capping tiles to prevent water, wind driven snow and debris entering under the tiles.

### Ridge



The underlay should be carried approx 150 mm over the ridge. The ridge board should be fixed after the topmost purlins. The thickness of the ridge board ought to be approx. 25-32 mm so that the ridge capping tiles can be securely nailed to it.

The use of a closer is recommended at the ridge.

A ventilated ridge is not recommended. Ventilation should be arranged via the ventilation gap below the ridge and through the gable ends of the building with suction ventilators on the ridge. In a ventilated ridge system the underlay is left open at the ridge and a ventilated ridge closer is used. It is fastened to the ridge board, and its sides are bonded to the tiles by the width of the adhesive strip.

### Penetrations and upturns at wall abutments

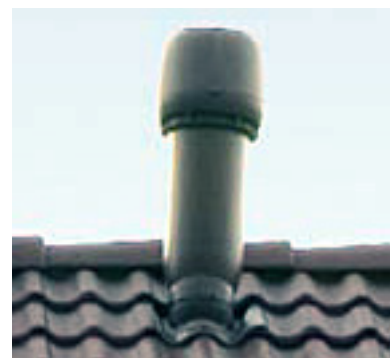

The penetrations in a concrete tile roof are usually made with purpose-designed fittings. If these are not viable, appropriate sleeves or sheetmetal flashings may be applied. It is desirable to locate the penetrations to match the purlin and tile layout, using additional purlins if necessary. Penetrations should be located as close to the ridge as possible. Ducts or similar penetrations should not be situated at valleys. Snow barriers may be installed above penetrations and rooflights if necessary. The purlin above a penetration must be 22 mm higher than the others in places where the tiles do not rest on the lower row.

At wall abutments, the underlay should be turned up well above the tile roofing and its upper edge fastened mechanically. Apron flashing, starting at a min. distance of 300 mm above the roofing is then folded over it. The apron flashing should extend 150 – 200 mm over the roofing (at least over one undulation). Above chimneys and ducts the flashing is usually continued up to the ridge.



## Roof hatch

Industrially manufactured roof hatches or hatches specially made for the project may be used. When a hatch is installed the following issues should be allowed for in the installation phase:

- A roof hatch should always be situated as close to the ridge as possible.
- The opening made in the underlay to allow access to the roof space should be executed so that water running from above cannot enter through the opening. A diverter should be installed above the hatch

to direct water possibly running over the underlay past the hatch.

- A skirting should be built around the opening to provide support to the underlay.
- The area around the opening may have to be close boarded to provide sufficient support.
- The hatch should be supported so that snow loads or traffic through the hatch cannot cause buckling of the hatch.
- The surround of the hatch should be sealed adequately to prevent moisture from the outside dripping over the underlay.

## Roof safety fittings

When installing snow barriers, supports for roof platforms and ladders, it is important to cut a sufficient notch in the throating on the underside of the tile as required by the thickness and width of the unit. This ensures that the tile above the safety feature concerned does not break. The supports of safety installations should be fastened to the loadbearing frame or separate, extra purlins as instructed by the manufacturer.

## Quality requirements

The following table contains the principle quality requirements for the installation of tile roofing. It is intended to harmonise the practices of the trade and to clarify what can be expected of the work and how it should be carried out.

Deck structure of tile roofing	<ul style="list-style-type: none"> <li>• The underlay must meet the applicable product class requirements</li> <li>• The underlay should be overlapped by a min. of 150 mm at horizontal and vertical joints</li> <li>• A batten to create a ventilation gap should always be installed between the underlay and the purlins</li> <li>• The roof tile battens (purlins) should be spaced at equal distances on each slope to keep the tile rows straight</li> <li>• Sufficient upturns of the underlay must be ensured at penetrations and wall abutments</li> <li>• The underlay must be installed so that water running down the underlay cannot seep into the roof structure at the underlay joints</li> </ul>
Installation of tile roofing	<ul style="list-style-type: none"> <li>• The installation of roofing tiles is always started from the bottom right hand corner of the slope</li> <li>• The outermost tile rows at eaves and verges should always be mechanically fixed</li> <li>• Fasteners must be corrosion resistant, hot dip galvanised nails being the minimum requirement</li> <li>• When installing the tiles it should be ensured that the tile rows do not start to curve in the vertical direction</li> <li>• You should make sure that no individual tiles stand proud of their environment during the installation stage</li> </ul>
Valleys	<ul style="list-style-type: none"> <li>• The base of the valley must be executed so that the underlay does not sag under the sheetmetal valley strip</li> <li>• At valleys the tiles should lie evenly without single projecting tiles</li> <li>• Small pieces of tile may have to be secured with stone glue</li> <li>• The line of the tile edges should not extend more than 40 mm over the valley trough</li> </ul>
Penetrations and roof hatches	<ul style="list-style-type: none"> <li>• Penetration products designed for tiled roofs must be used</li> <li>• The weathertightness of penetrations must always be ensured, especially their connection with the underlay</li> <li>• Penetrations should be positioned so that at least one full tile can be fitted between any two</li> <li>• Penetrations should not be situated at valleys</li> <li>• The area around a roof hatch or other openings may have to be close boarded to provide sufficient support</li> </ul>
Flashings	<ul style="list-style-type: none"> <li>• Flashing should be fastened with appropriate fixings</li> <li>• The verge trim should extend at least over the first tile trough</li> <li>• Apron flashing must reach at least 300 mm up a wall surface and must extend sufficiently over the roofing</li> <li>• Edge drips should be installed if the eave detail and the gutter type so require</li> </ul>
Finished work	<ul style="list-style-type: none"> <li>• The horizontal and vertical rows should appear rectilinear on visual inspection</li> <li>• Singular projecting tiles in the roofing are not acceptable</li> <li>• The roof surface must be clean when the work is finished and the roof surface must not be used as storage or work area without protection</li> </ul>

# Detail Drawings (Tiled roofs)

## 1. Eaves

- Sarking installed over the roof trusses should extend at least 200 mm beyond the wall perimeter.
- Water running along the top of the sarking must be allowed to drain off via the decking ventilation gaps
- The tile battens installed over the counter battens ( $\geq 22$  mm) used for ventilation are specified according to the roofing material.
- The minimum width of the ventilation gap between the wall and the sarking is 25 mm and must be equipped with an insect net (mesh size 3-5 mm). Too wide a gap (over 50 mm) may cause "booming" noises from the sarking in strong winds.
- At eaves the lowest tile batten should be higher than the others by the thickness of the tile, so that the lowest row of tiles has a uniform rake with the rest of the tiles.
- The lowest tile should extend 40–50 mm over the fascia board and it is recommended to use a drip edge underneath it.
- The outer edge of the eaves gutter must be at least 25 mm below the roofing surface measured from the top surface of the tile trough.

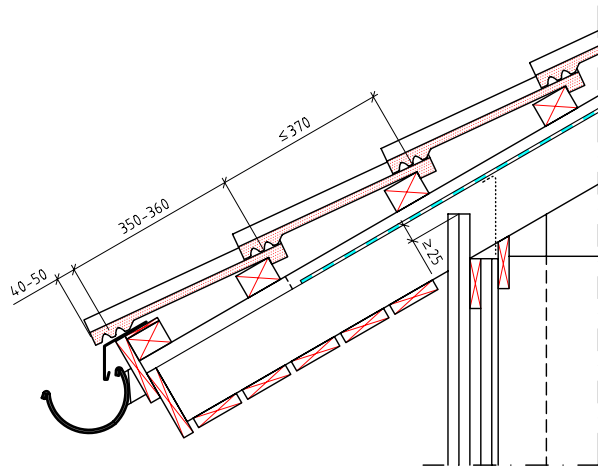

## 2. Eave, open construction

- The ends of the roof trusses should be bevelled by the combined depth of the roof decking and the counter batten (44 mm).
- The decking at the eave should be solid and battens are mounted on top of it so that their top surface coincides with the level of the roof trusses.
- The sarking is installed over the trusses and the battens are used for added height. The ends of the battens must extend 15-20 mm beyond the decking, and the lower end of the sarking should coincide with the lower edge of the decking. There must be a gap between the fascia board and the decking to allow water to drain off.
- The tile battens to be installed over the counter battens ( $\geq 22$  mm) used for ventilation are specified according to the roofing material.
- The minimum width of the ventilation gap between the wall and the timber deck is 25 mm and it must be equipped with an insect net (mesh size 3-5 mm).
- At eaves the lowest tile batten should be higher than the others by the thickness of the tile so that the lowest row of tiles has a uniform rake with the rest of the tiles.
- The lowest tile should extend 40–50 mm over the fascia board and it is recommended to use a drip edge underneath it.
- The outer edge of the eaves gutter must be at least 25 mm below the roofing surface measured from the top surface of the tile trough.

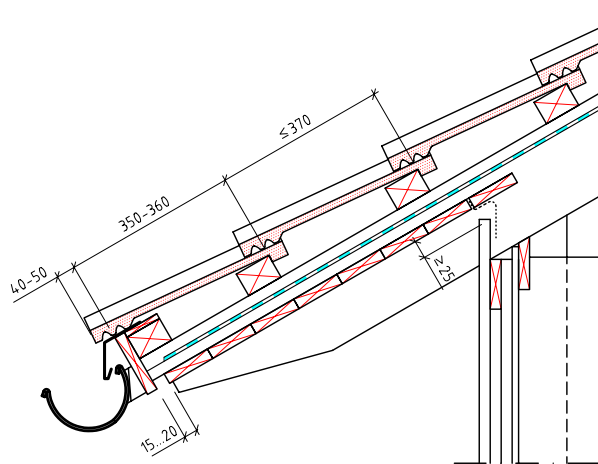

## 3. Verge

- The sarking installed over the roof trusses should extend to the outer edge of the verge.
- The verge detail may be executed with special verge tiles as shown here, or alternatively with a sheetmetal verge flashing.
- At the verge ventilation can be implemented either through the projecting verge (ventilation gap between the wall and the sarking  $\geq 30$  mm) or with vents placed as high up as possible. A storm stop can be mounted on the part of the wall to prevent rain being driven up the gap, if necessary.
- The verge ventilation can be replaced by arranging ventilation along the ridge (suction ventilators).
- The bending stiffness of a verge supported by purlins as shown must be ensured, or else the timbers must be joined for support to at least two roof trusses (compare to verge detail in sheetmetal roofing, see Fig. 2, p. 58).

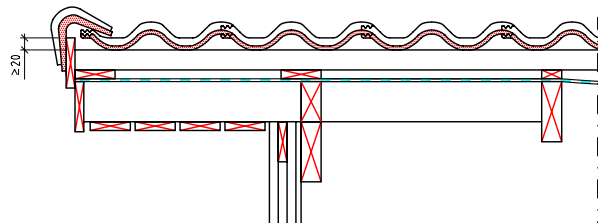

#### 4. Ridge

- The sarking should lap at least 150 mm over the ridge.
- The gap between the ridge capping tiles and the roof tiles on the slope must be sealed.
- The ridge cap units should be fixed to a board 25-30 mm in thickness.

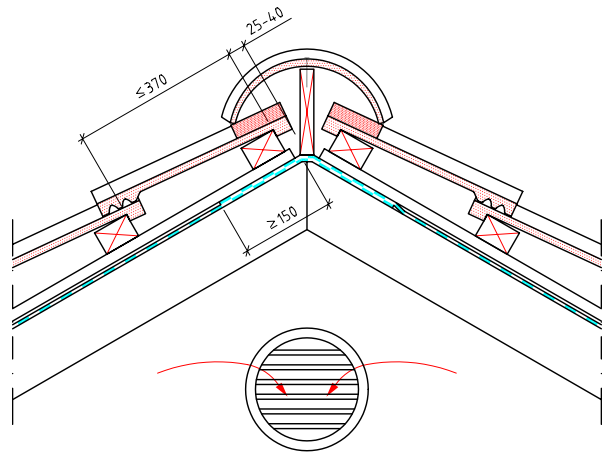

#### 5. Valley

- A solid deck is constructed at the valley (at least 300 mm on both sides). The surface of the boarded area must be level with the roof trusses.
- Sarking or a bituminous membrane is installed along the base of the valley and the sarking of the slopes is lapped over it.
- The ends of the counter battens applied for ventilation are left 25-40 mm short of the valley base (valley ventilation gap).
- Cross members are installed over the counter battens in the direction of the valley (thicker than regular tile battens or extended by a fillet), and the valley sheetmetal gutter is then installed on top.
- At the valley the roof tiles are cut to align with the valley. A valley gutter of at least 200 mm is left between the tiles.
- If necessary the gap between the sheetmetal gutter and the tiles is sealed.

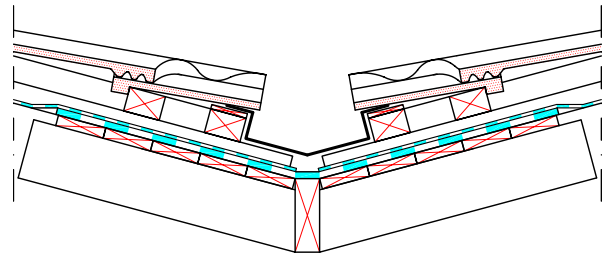

#### 6. Upturn

- At the upper edge of the slope the sarking is turned up to extend at least 300 mm above the surface of the roofing so that the space below the sarking can be ventilated through the upturn.
- The upturn flashing is lapped over the roofing by at least 100 mm and sealed. The apron flashing should be installed so as to allow for ventilation of the space above the sarking via a gap incorporated in the detail.

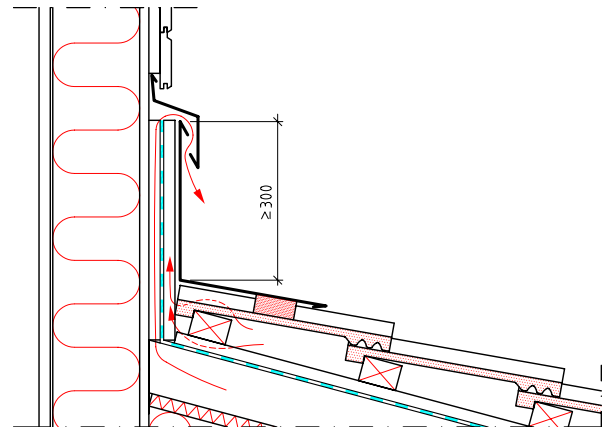

#### 7. Side wall abutment

- At a side wall abutment the sarking is turned up to extend at least 300 mm above the surface of the roofing.
- The abutment flashing is extended at least over the second peak of the roof tiling and sealed if necessary (see Fig. 6, p. 59) against the wall structure above the upper edge of the sarking. Separate sealing is not needed if the wall cladding protects the top edge of the upturn (as shown).

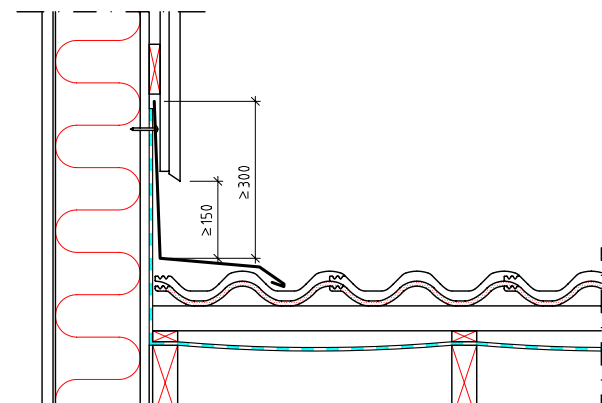



## 8. Roof penetrations

- The sarking should be raised at the penetration to prevent water entering the structure. This can usually be done with commercially available sleeves for sarking.
- Small penetrations (such as drain vent stacks) are usually sealed by using special tiles. A flexible pipe section is used below the roofing to align the pipe with the special tile. The pipe section that penetrates the roof must be secured to the roof structure below the tile.
- A snow guard is installed above the penetration if necessary.
- At a chimney, flue group or other such component the sarking is turned up against the component above the roofing surface.
- Below the chimney the flashing is overlapped by at least 100 mm and along the sides over the first tile peak (supported from underneath if needed). In tiled roofs the flashing is usually continued up to the ridge.
- If the chimney is not in the immediate vicinity of the ridge, a guide made of the sarking should be used to direct the flow of water.
- The chimney flashing is either extended to the top of the chimney or turned up and sealed to at least 300 mm above the surface of the roofing.

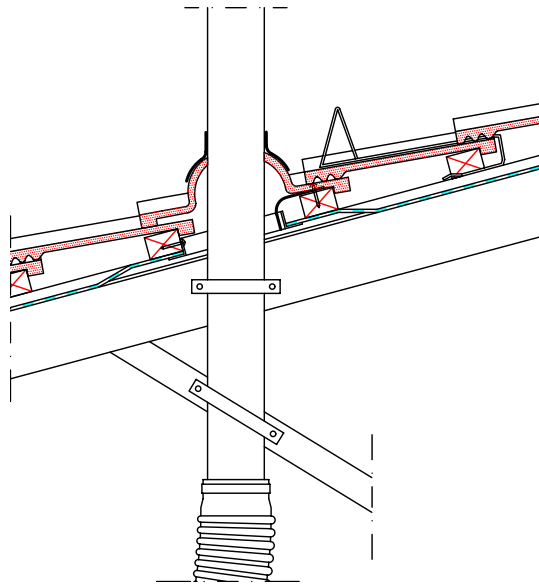

## 9. and 10. Roof hatch

- At a roof hatch the sarking is raised and connected to a frame made for the hatch assembly to prevent water from entering the structure.
- If the hatch is not in the immediate vicinity of the ridge a guide should be made from the sarking to direct the flow of water.
- The actual hatch assembly is connected to the tiling according to manufacturer's instructions.

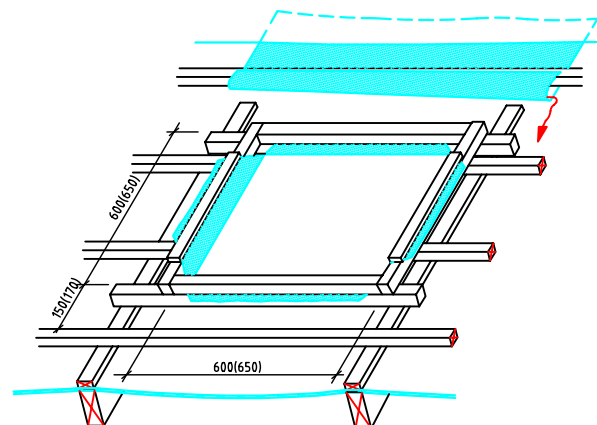
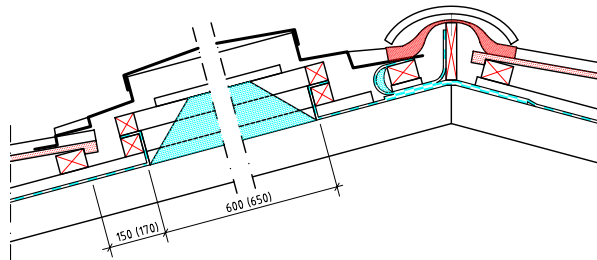

# Contract procedure

## How to find a roofing professional

When your own expertise is not enough, it is wise to use the services of professionals. There are many possibilities, ranging from the neighbour's building foreman to major construction management firms. Below are listed a few basic things to ask when making your choice:

- make sure that the person has the time and motivation to see the project through properly
- make sure that they have experience of commercial and contractual issues in the building sector
- make sure that they have knowledge about roofs and having them built.

### Construction management firms

A construction management firm is usually a good choice. In selecting a consultancy it is wise to take into consideration their experience in refurbishment and especially in roof structures.

### Construction sector professional

A construction sector professional who has practical experience can easily take care of the necessary invitation to tender documents and other routines.

### Roofing sector professional

For technical issues an experienced roofing sector professional is perhaps the best choice. Particularly in refurbishment projects, experience on various roof systems and knowing the different stages of execution will be useful.

### Property manager

A property manager's ability to take care of a roofing project depends on their educational background and experience. A skilful property manager is often very committed to the task and knows the contractual side of the project.

## Information available – just ask

There is no one single authority on roofing issues who could provide an answer to your every question at once. There are many good sources of information, including the Finnish Roofing

Association, roof contractors, material suppliers and design consultancies with experience of roof work. Take the initiative in using their expertise, but listen to them critically.

## What type of contractor are you looking for?

There are dozens of roofing contractors in Finland. You cannot request a tender from all of them and it is not even necessary. Start from your own needs.

Think about what you ultimately need from your contractor. Often a company's expertise influences its operational policy, its ability to take responsibility for risks, its flexibility and also its desire and ability to take on board the details of the project. A special area of expertise required in the project may also be a deciding factor in choosing a contractor.

Once you have considered the key criteria, you can pick the contractors to whom you send an invitation to tender. You can also make sure, prior to sending the tender document, that these companies actually do have resources available when you need them.

## The Finnish Roofing Association's follow-up report

When you want to know whether the roofing contractors have met their statutory payment obligations, ask the contractors for a follow-up report. This is a monthly updated form with basic data on the contractor. It is based on the information given by the Finnish Trade Register, the tax authorities and the LEL Employment Pension Fund. It covers the basic data on the company, registration in the Prepayment Register and VAT number. This one-page report also indicates whether the company has paid its taxes and LEL pension contributions. These are important facts when you consider who you want to do business with. You will receive the follow-up report from the contractors appended to the bid.

## How do you recognise a good contractor?

A good contractor is one that executes your project well, punctually, reliably and on mutually agreed terms. However, there are a few issues worth noting. A quick checklist to keep in mind:

### A good contractor

- makes clear and understandable bids and contracts
- informs the client clearly and in good time of the requirements, risks, scheduling and working times of the project
- takes the initiative to organise intermediate and final inspections
- provides appropriate written documentation on its areas of expertise and reference projects
- complies with the plans, general guidelines and stipulations
- follows the roofing sector product and use class guidelines
- is financially sound and can verify that they meet their statutory obligations
- investigates the project before tendering
- abides by hot work guidelines of the sector safety-at-work regulations
- invests in the training and skills of their workers
- takes care of insurance

## Quality of contracted work

The implementation of the work forms a major part of roofing contracting. The client should investigate the contractor's operating policy and practice and how it is ensured that the work meets agreed standards.

The client should see to it that supervision is sufficiently efficient and professional. This ensures that the work progresses as scheduled and the result complies with what has been agreed. Particularly important is that the client or their representative can provide an informed stand during the work on possible amendments to work or extra work.

Good execution of work also implies that a specialist contractor will not implement a bad or non-viable roofing

plan without informing the client of the fact. Even if the client demands it, a predictably unworkable project should not be implemented. Despite what is said above, the contractor may be forced to execute details that are contrary to good building practice. However, it is advisable to inform the client of these in writing and to refuse responsibility for them.

The key quality requirements of contracted work are compiled on page 28.

## Invitation to tender

It is worth investing in a good invitation to tender, as this defines the quality of the result. Make sure that all invitations to different companies contain the same information so that you will receive fully comparable bids. Once you have shortlisted the contractors, send invitations to 3–5 of the most interesting companies.

### Use expert services

Using an expert in drawing up an invitation to tender often saves you a lot of trouble – which might appear later, e.g. the initial cost estimate might be exceeded as some vital issue was not included in the contract.

### An invitation to tender should include the following:

#### Basic data

- who is inviting tenders
- contact information
- deadline for tenders
- site address
- project/building under contract: e.g. Housing Company X street 12, buildings A and C
- access to roof, is there an external ladder, are keys needed etc.
- person available for site evaluation and contact info
- desired work period

#### Project description:

- age of building and known repairs
- insulation material and thickness
- structural principles of building (copies of sectional drawings)
- drawings:
  - site plan, especially if more than one roof involved
  - roof plan
- photographs if necessary

- roofing system
- roof shape (flat, hipped, pitched)
- elevation drawings
- refurbishment plan
- projected life span of roof, changes of use etc.
- other repairs carried out concurrently
- known fire and safety risks
- problems with the roof and actions taken
- is there asbestos or other materials presenting a health hazard

Pay careful attention to insurance issues

### Ensure that insurances are taken care of

Even when operating with care and professionally, accidents can happen. It is important that accidents are provided for, in terms of the financial consequences as well.

It can be said that refurbishment is riskier than new construction. When making a choice, consider the contractor's level of experience.

The most typical roofing accidents include various types of small leak damage during work and weather damage. In view of the work and the number of sites involved, instances of damage are rare, and they often they happen as a sum of many coincidences.

### The client is responsible for taking out a fire insurance

According to YSE 1998 (General Contract Terms), in refurbishment projects the client is responsible for the fire insurance of a building. There are two good reasons for this: usually properties have a fire insurance in place (e.g. as part of the property insurance), and on the other hand the owner of the property knows its value. Double insurance is not an option worth considering.

If the client has neglected the fire insurance contrary to what has been agreed, any loss shall be borne by the client. In this instance the contractor is not liable for damages unless caused by gross negligence.

If the property is a residential property, it is advisable that the residents have a

home insurance. This will ensure that they are compensated directly by the insurance company for any damage to their movable property and thus many problems are avoided. Any possible disputes on the contractor's liability are handled by the insurance company.

### Keep your insurance company updated

Before commencing the contract the client must inform the insurance company with which the property is insured against fire about the refurbishment. At the same time it is advisable to check the deductible of the insurance as in some cases it may increase many times over.

### Demand that the contractor has a liability insurance

Few contractors are sufficiently solvent to pay large compensation sums without insurance coverage. The contractor must therefore have a liability insurance covering the type of work carried out. A document of such an insurance, e.g. an insurance certificate should always be demanded. This insurance covers the various types of damage that the contractor may cause while carrying out the work. However, a liability insurance does not cover property where work is in progress.

If there is no insurance, compensation for damage depends solely on the solvency of the contractor.

### Subcontractors must have their own insurance

If a contractor employs a subcontractor, they (the subcontractor) must have an insurance that covers their operations, as the main contractor's insurance generally does not cover damage caused by a subcontractor.

### Liability insurance alone not always sufficient

A liability insurance does not always cover damage caused to the actual object of the work (e.g. roofing) during construction. According to YSE 1998, the insuring of the work in progress is the responsibility of the contractor unless otherwise agreed. Thus the contractor is responsible for the unfinished work and materials. This



can be covered by a construction work insurance. The necessity for this has to be evaluated on a case-by-case basis. On one hand, the considerations include the size of the project, the value of the contract and terms of payment as well as the contractor's ability to bear the liability and on the other hand, the client's ability to undertake risks. The contractor takes out the construction work insurance and will naturally charge the insurance fee as part of the contract price.

### **No shortcuts in fire or work safety even in tight competition situations.**

The roofing contractor is responsible for the safety of their workers and third parties during the contract period. There are clear regulations on fire and work safety in place and they must be followed.

Compliance with guidelines also reflects the contractor's responsible, reliable and professional attitude.

For the benefit of all parties fire and work safety issues have improved during the past years, e.g. through training and cooperation within the sector.

Shortlist of contractor's obligations:

#### Safety at work

- provide safety railings at eaves and verges (height over 3 m)
- ensure safe access to roof
- ensure the safety of the site around the building
- place warning signs in the yard to notify those moving there
- provide information on possible disruptions in the staircase
- provide notice board and data on contractor's contact person
- provide protection at entry point to the building

#### Fire safety

- Abide by the roofing and waterproofing safety guide
- Ensure hot work permits for roofing and waterproofing sector
- Carry out inspections required by the hot work checklist / hot work permission before commencing hot work

- Provide equipment for initial extinguishing, at least two 12 kg 43A 183 B-C class extinguishers
- Provide fire watch after hot work
- Ensure work methods are chosen with a view to fire safety issues at the site

### **Contract documents are for reading**

Before signing the construction contract the parties should define clearly and sufficiently accurately all the factors that included in the contract and affecting its implementation, questions of liability, payments, warranty and possible disputes. The more clearly the issues are set out, the more smoothly the project will progress. This stage can be greatly facilitated by paying sufficient attention to detail already at the stage of tender invitations.

#### **General conditions**

The general terms and conditions of construction contracts YSE 1998 (RT 16-10660, Building Information File) are followed in the Finnish Roofing Association. We recommend operating with YSE based contracts as they already contain the rules for the most common problem situations occurring in connection with construction contracts.

The contract conditions applying to contracts where the client is a private person (REYS and RYS) have been drawn up together with the Consumer Ombudsman and they are based on the Consumer Protection Act. With consumers the other parties involved must abide by the rules that apply to b-to-c trading. Housing and real estate companies as clients are not consumers.

#### **Demand a good warranty**

The contractor must provide the client with a specific warranty that stipulates the applicable conditions.

The warranty applies to roofing work carried out according to good working practices acknowledged at any one time, prime quality of the roofing materials and weathertightness of the roofing. Roofing materials include

membranes, roof drains, suction ventilators and sleeves.

The warranty is valid for the benefit of any owner of the building. The client's responsibility is to report any faults and damage detected without delay to the contractor who has issued the warranty. The Finnish Roofing Association recommends a warranty of 10 years for conventional low pitched roofs that have been built according to the use classification of bitumen membrane roofing. For other roofs and waterproofing, a warranty period according to YSE 1998 is recommended.

Obviously the following cases are excluded from the warranty liability as the contractor has no control over them:

- storm damage
- damage caused by neglect of maintenance
- damage caused by third parties

However, within the scope of the warranty repair of damage caused by leaks has been included up to the contract sum.

In consumer trade the consumer's protection is determined according to the Consumer Protection Act and contract conditions based on the Act. Consumers receive a separate handover certificate, the receipt of which they confirm by their signature. By issuing the handover certificate the contractor confirms the handover of a finished product to the consumer.

The maintenance instructions of the roof are printed on the back of the certificate. The consumer's rights in case of a possible dispute or fault is stipulated by the Consumer Protection Act. Receiving the handover certificate does not mean that the consumer has accepted the work carried out and it does not diminish the consumer's statutory rights to complain about possible faults.

# Maintenance



## Good maintenance adds years to the life span of a roof

Use of the correct roofing systems and professional implementation are the key factors for a good roof. However, they alone cannot guarantee the functioning of a roof. For a roof to fulfil its function as expected throughout its life span – as with all technical structures – maintenance is required.

Regular inspection and timely maintenance ensure the functioning of a roof, increase its life span and significantly reduce the life-cycle cost of the roof. It is also worth remembering that damage caused by the neglect of maintenance does not fall within the scope of the contractor's liability.

To emphasise the significance of roof maintenance and to facilitate the work of those responsible for property maintenance, the Finnish Roofing Association has produced a Roof Maintenance Manual in the same spirit as the Roofing Systems Manual. With the manual, inspections and maintenance can be carried out regularly and properly and their documentation will also be ensured.

The roofing contractor should provide the Roof Maintenance Manual for appending to the maintenance manual of the property concerned.



## The Finnish Roofing Association

- represents its members in relations with authorities who regulate the building industry, other organisations and third parties. The association bears partial responsibility for setting up norms for the sector and provides statements on general issues relating to the sector
- promotes research and investigation work to develop the roofing systems and work methods best suited to Finnish conditions and implements the circulation of relevant guidelines among entrepreneurs in the sector
- develops contract terms suited for the sector and monitors compliance with these – to the benefit of its members and the entire construction industry
- promotes safety at work and fire safety in cooperation with the authorities and insurance companies
- develops employee training and educates office staff working in the sector with the goal of continuous improvement of know-how and skills within the sector
- takes responsibility for its own part for the advisory, informative and communication activities of the roofing sector targeted at construction clients
- follows the international development of the sector through professional literature, international exhibitions and direct contacts
- concludes collective labour agreements for the sector.

## Working for better roofs since the sixties

### *In 1964*

entrepreneurs in the waterproofing industry founded the Flat Roof Contractors' Association with the aim of promoting the shared interests of the industry.

### *From 1981 until the end of January 1992*

the association was known as the Association of Roofing Contractors, which better represented the expanding operations of its member companies.

### *January 1992*

the association expanded its scope to collective agreements and adopted the name the Finnish Roofing Association

### *In spring 1995*

the sector's material and equipment suppliers joined the association's activities as an industrial associate.

### *In 2004*

to celebrate the association's 40th anniversary the association published its history, *The Fifth Facade*, edited by Lauri Seppänen.

A continually updated version (in Finnish) of the Roofing Systems Manual is available at the association's website ([www.kattoliitto.fi](http://www.kattoliitto.fi)). Appended is a complete list of additions, amendments and their dates.



# Roofing and waterproofing regulations and guidelines

## Ministry of the Environment:

National Building Code of Finland C2  
Moisture

Moisture in construction  
National Building Code of Finland (RakMK) C2, guide

National Building Code of Finland E1  
Fire safety of buildings

Fire Safety of Buildings & Fire Safety in Refurbishment Work, guide

National Building Code of Finland A4  
Building Use and Maintenance Manual

## Finnish Government:

Construction and Safety 629/94, government decision

## Finnish Association of Civil Engineers

RIL 107-2000  
Water and dampproofing guidelines for buildings

## The Building Information Foundation

Runko RYL 2000  
Finnish Building Information File, sections of roofs and waterproofing

## Certificates

VTT Certification Criteria of Bitumen Roofs  
part 1 Products  
part 2 Contract work

## Finnish National Rescue Association (SPEK):

Roofing and Waterproofing Safety Guide

## Publishing house Rakennusalan Kustantajat RAK:

Construction Safety Regulations and their Explanations  
Roofs and Waterproofing

## Harmonised product standards and CE marking

Construction Product Directive

SFS-EN 544

SFS-EN 13707

SFS-EN 13969

SFS-EN 13970

SFS-EN 13859-1



# The members of the Finnish Roofing Association cover all Finland

## Contractor members

### **AL-Katot Oy**

www.al-katot.fi  
Viisaritie 2, 01640 VANTAA  
+358 9 727 1480

### **Pirkkala**

Taitajankuja 3, 33960 PIRKKALA  
+358 3 368 1566

### **Pori**

Tampereentie 1, 28130 PORI  
+358 2 529 8888

### **Riihimäki**

Petsamonkatu 92, 11120 RIIHIMÄKI  
+358 19 725 933

### **Savitaipale**

Torikatu 16, 54800 SAVITAIPALE  
+358 5 416 0085

### **Turku**

Kuninkaanojantie 70, 20320 TURKU  
+358 40 5737 117

### **Anttikatot Oy**

www.anttikatot.fi  
PL 3 (Aromikukkaronatie 25),  
21421 LIETO  
+358 2 487 1020

### **A-Tiilikateasennus Oy**

www.a-tiilikate.fi  
Kuovintie 7, 21380 AURA  
+358 2 486 460

### **Eristys Mara Oy**

www.eristysmara.fi  
Otsotie 13, 01900 NURMIJÄRVI  
+358 9 250 6201

### **Eristysliike Lasse Laine Oy**

Punapakantie 287,  
29270 HORMISTO  
+358 2 537 4472

### **Eristysliike Sarttila Oy**

www.sarttila.fi  
Torpankatu 4, 24100 SALO  
+358 2 727 1100

### **Vantaa**

Myyrmäentie 2, 1 krs,  
01600 VANTAA  
+358 9 4730 1191

### **Eristysmestarit Oy**

Nietostie 10 B, 01390 VANTAA  
+358 9 825 4180

### **Hämeen Kate Oy**

Perkkoonkatu 5, 33850 TAMPERE  
+358 3 343 6400

### **Icopal Katto Oy**

www.icopal.fi  
Länt. Teollisuuskatu 10,  
02920 ESPOO  
+358 20 743 6200

### **Itä-Suomen alue**

020 743 6200  
Kisällinkatu 8, 70780  
KUOPIO

### **Keski-Suomen alue**

020 743 6200  
Kuoppamäentie 11, 33800  
TAMPERE

### **Kouvola**

020 743 6586  
Reijulankatu 6, 45130  
KOUVOLA

### **Länsi-Suomen alue**

020 743 6200  
Hiidenkatu 9, 20360 TURKU

### **Katepalvelu Oy**

www.katepalvelu.fi  
Vähtäväntie 11 C, 00390 HELSINKI  
+358 9 548 4399

### **Katman Oy**

www.katman.fi  
Laakeritie 18, 90630 OULU  
+358 8 570 2000

### **Rovaniemi**

Teollisuustie 18, 96320 ROVANIEMI  
+358 16 425 5100

### **Kattamisliike Tallqvist Oy**

www.kattamisliike.com  
Helsingintie 9 A, 24100 SALO  
+358 2 737 3173

### **Kattava Oy**

www.kattava.fi  
PL 32, 20381 TURKU  
+358 2 471 8181

### **Katterla Oy**

www.katterla.fi  
Sammaltie 76, 90650 OULU  
+358 8 535 0400

### **Kuopio**

Likolammentie 24, 70460 KUOPIO  
+358 400 576 585

### **Katto 2000 Oy**

www.katto2000.fi  
Akkutie 26 B,  
00770 HELSINKI  
+358 9 388 2052

### **Katto-Team AP Oy**

PL 136,  
45101 KOUVOLA  
+358 5 311 8870

### **Kemin Kate Oy**

Pankonkatu 29,  
94700 KEMI  
+358 16 231 021

### **Kimto Markkinointi Oy**

www.kimto.fi  
Marttilankatu 4,  
48600 KOTKA  
+358 5 260 8428

### **Kuusaan Pintakate Oy**

www.kuusaanpintakate.fi  
Radanvarsi 7,  
45910 VOIKKAA  
+358 400 652 289

### **Lahten Bitumikate Oy**

Peltiseppänpolku 11,  
80400 YLÄMYLKY  
+358 50 349 2142

### **Lemminkäinen Katto Oy**

www.lemminkainen.fi  
www.laatu-katto.com  
PL 10 (Puusepäntie 14),  
04361 TUUSULA  
+358 20 715 0400

### **Lahti**

Höylääjänselkäntie 6, 15520 LAHTI  
+358 20 715 0412

### **Turku**

Voimakatu 13, 20520 TURKU  
+358 20 715 0413

### **Kuopio**

Yrittäjäntie 17, 70150 KUOPIO  
+358 20 715 0414

### **Vaasa**

Teollisuustie 11,  
65610 MUSTASAARI  
+358 20 715 0415

### **Lappeenranta**

Ruukintie 9, 53500 LAPPEENRANTA  
+358 20 715 0416

### **Pori**

Satakunnankatu 43, 28130 PORI  
+358 20 715 0417

### **Kotka**

Valajantie 7, 48230 KOTKA  
+358 20 715 0418

### **Hämeenlinna**

Tölkkiämentie 4,  
13130 HÄMEENLINNA  
+358 20 715 0419

### **Oulu**

Sälpätie 5, 90630 OULU  
+358 20 715 0423

### **Lohja**

Puistokatu 25, 08150 LOHJA  
+358 20 715 0420

### **Joensuu**

Parrutie 1, 80100 JOENSUU  
+358 20 715 0422

### **Jyväskylä**

Vehkakuja 4, 40700 JYVÄSKYLÄ  
+358 20 715 0424

### **Tampere**

Possijärvenkatu 3, 33400 TAMPERE  
+358 20 715 0425

### **Lohjan Kattoexpertit Oy**

www.lohjan-kattoexpertit.fi  
Raspiikuja 2,  
08500 LOHJA  
+358 44 047 1908

### **Länsi-Kate Oy**

www.lansikate.fi  
Vaihetie 3,  
60120 SEINÄJOKI  
+358 6 423 4040

### **MH-Kate Oy**

www.mh-kate.fi  
Koulutie 1, Tuomikylä,  
60720 VAASA  
+358 6 417 1100

### **Protan Kattopalvelu Oy**

www.protan.fi  
Koivuhaantie 18, 01510 VANTAA  
+358 20 741 0400

### **Tornio**

Kemintie 46, 95420 TORNIO  
+358 20 741 0413

### **Kälviä**

Kumpulantie 39, 68300 KÄLVIA  
+358 20 741 0416

### **Raisio**

Karhutie 1, 21220 RAISIO  
+358 20 741 0414

### **Tampere**

Sammon valtatie 10,  
33530 TAMPERE  
+358 20 741 0401

### **Rakennuspalvelu Jarmo Mäntylä Oy**

www.katot.fi  
Uomatie 11, 01600 VANTAA  
+358 9 452 5230

### **Rautaruukki Oyj**

www.ruukki.com  
PL 77 (Rakentajantie 26)  
20781 KAARINA  
+358 20 591 27

### **Espoo**

Koskelontie 21, 02920 ESPOO  
+358 20 592 1719

### **Tampereen Bitumikate Oy**

www.bitumikate.net  
Kaskimäenkatu 4,  
33900 TAMPERE  
+358 3 211 0400

### **Tampereen Katehuolto Oy**

www.katehuolto.fi  
Vehnamyllynkatu 33,  
33560 TAMPERE  
+358 3 363 5202

### **Turun Takuukatto Oy**

www.takuukatto.fi  
PL 137, 20521 TURKU  
+358 2 470 4941

### **Tähtieristys Oy**

PL 29 (Puistokatu 23),  
40101 JYVÄSKYLÄ  
+358 40 546 5028

### **Uudenmaan Bitumikate Oy**

www.bitumikate.com  
Ruusumäentie 1 B, 01730 VANTAA  
+358 9 276 7550

### **Vesikattoliike Mäkinen Oy**

www.vesikattoliikemakinen.fi  
Valmetintie 22, 40420 JYSKÄ  
+358 14 261 558

## Manufacturer members

### **Dow Suomi Oy**

www.dow.com  
Urho Kekkonen katu 7 B,  
00100 HELSINKI  
+358 9 5845 5300

### **Eltete Oy**

www.eltete.com  
Varastokuja 5, 07900 LOVIISA  
+358 19 51031

### **Icopal Oy**

www.icopal.fi  
Läntinen teollisuuskatu 10,  
02920 ESPOO  
+358 20 743 6200

### **Katepal Oy**

www.katepal.fi  
PL 33, 37501 LEMPÄÄLÄ  
+358 3 375 9111

### **Monier Oy**

www.monier.com  
Sinikalliontie 9, 02630 ESPOO  
+358 9 253 3771

### **Lemminkäinen Katto Oy**

www.lemminkainen.fi  
Puistokatu 25-27, 08150 LOHJA  
+358 20 715 0420

### **maxit Oy Ab**

www.maxit.fi  
PL 70 (Strömberginkuja 2),  
00381 HELSINKI  
+358 10 442 200

### **Paroc Oy Ab**

www.paroc.fi  
PL 294 (Neilikkatie 17),  
01301 VANTAA  
+358 20 455 4868

### **Peltitarvike Oy**

www.peltitarvike.fi  
Kytikintie 25,  
00770 HELSINKI  
+358 20 741 2770

### **Rakonor Oy**

www.rakonor.fi  
Mänkimihentie 19,  
02780 ESPOO  
+358 9 439 3460

### **Rautaruukki Oyj**

Rakentamisen ratkaisut  
www.ruukki.com  
PL 35 (Teknobulevardi 3 - 5),  
01531 VANTAA  
+358 20 59127

### **Rockwool A/S, Finland branch**

www.rockwool.fi  
PL 29 (Piispanportti 10),  
02201 ESPOO  
+358 9 8563 5880

### **Saint Gobain Isover Oy**

www.isover.fi  
PL 250,  
05801 HYVINKÄÄ  
+358 19 45 601

### **SFS Intec Oy**

www.sfsintec.biz.fi  
PL 31 (Tarrantie 4),  
08501 LOHJA AS.  
+358 19 357 030

### **Oy Sika Finland Ab**

www.sika.com  
PL 49 (Koskelontie 23 C),  
02921 ESPOO  
+358 9 511 431

### **SK-Tuote Oy**

www.sk-tuote.fi  
Kauppatie 9, 65610 MUSTASAARI  
+358 20 122 3200

### **ThermiSol Oy**

www.thermisol.fi  
Torvantie 18, 38210 SASTAMALA  
+358 3 5161

### **Trelleborg Building Systems Oy**

www.trelleborg.fi  
Peltopolku 2, 03400 VIHTI  
+358 9 224 2850



The Finnish Roofing Association

Kattoliitto ry, Unioninkatu 14, 00130 Helsinki, puh. (09) 663 766, faksi 663 630, www.kattoliitto.fi

etunimi.sukunimi@kattoliitto.fi tai kattoliitto@kattoliitto.fi