

Henry®

PERMAX™ Maximum Insulating Power™
By Henry.



Polyurethane Roofing Installation Manual

INDEX

Section 1	Description of Roof System
Section 2	General Requirements
Section 3	Pre-Construction Meeting
Section 4	R-Value
Section 5	Storage and Handling
Section 6	Quality Control
Section 7	Decks and Substrates
Section 8	Roof Deck Preparation
Section 9	Edge Metal Requirements
Section 10	HVAC Platform Requirements
Section 11	Roof Drain Requirements
Section 12	Primer Selection
Section 13	Foam Processing/Trouble Shooting
Section 14	Polyurethane Foam Application
Section 15	Polyurethane Foam Blisters, and Repair
Section 16	Parapet Details
Section 17	Elastomeric Coating Application
Section 18	Coating Blister Identification and Repair
Section 19	Application of Walkway Materials
Section 20	Maintenance Re-Coating
Section 21	Conduit Attachment
Section 22	Roofing Details
Section 23	Forms

PERMAX[®] POLYURETHANE ROOFING INSTALLATION MANUAL

SECTION 1

DESCRIPTION OF ROOF SYSTEM

- A. This manual covers the installation of the, Sprayed Polyurethane Roofing System (SPRS) which consists of a seamless sprayed-in-place polyurethane foam insulation covered with an elastomeric coating for use as an insulated roofing system for both new and retrofit (re-roofing) construction. The coating system may have an option for a single or double layer of ceramic granules to be embedded into the final wet coat of elastomeric coating.

- B. The successful application of a SPRS is dependent upon the experience, technology and common sense of the designer and applicator/contractor. This manual is intended to define the Permax[®] Henry minimum requirements for a successful roof application and meet specific requirements for the RTC / Warranty Program. But this information is dependent upon the roofing contractors experience and common sense to solve any design problems, which may occur and comply with building code and safety requirements. The successful application of a SPRS is dependent upon the experience, integrity and ability of the contractor.

PERMAX[®]
POLYURETHANE ROOFING
INSTALLATION MANUAL

SECTION 2

GENERAL REQUIREMENTS

- A. Contractors engaged in the installation of these roofing systems must be licensed for this work (roofing license) if required in the State(s) which they are working in.
- B. All State and Federal regulations and safety precautions including OSHA, fire protection, inhalation hazards, and fall protection shall be observed.
- C. Continuous education in product, equipment, application, and safety programs provided by NRCA, SPFA, and ICAA should be observed and training for employees shall be offered. Mandatory safety, hazardous communications, and regulated company safety meetings shall be provided.
- D. All companies engaged in the installation of SPF materials shall have current training with the following minimum programs in place;
 - 1. Hazardous Communication Program
 - 2. Injury Illness Prevention Program (IIPP)
 - 3. Respirator Compliance Program
 - 4. MSDS Training
- E. **Disclaimer.** Technical Bulletins; Read these documents and determine that, "The information herein is to assist customers in determining whether our products are suitable for their applications. We request that customers inspect and test our products before use and satisfy themselves as to contents and suitability. Our products are intended for sale to industrial and commercial customers. We warranty that our products will meet our written specifications. Nothing herein shall constitute any other warranty expressed or implied, including any warranty of merchantability or fitness, nor is protection from any law or patent to be inferred. The exclusive remedy for all proven claims is replacement of our materials and in no event shall we be liable for special, incidental, or consequential damages."

PERMAX[®]
POLYURETHANE ROOFING
INSTALLATION MANUAL

SECTION 3

PRE-CONSTRUCTION MEETING

- A. Prior to commencement of the work, the successful **contractor** shall hold a mandatory pre-construction meeting with the owner's representative. A representative of RTC may attend this meeting. The contract documents, specifications, and scope of work shall be reviewed and confirmed in writing. The following completed forms and information shall be delivered at this meeting;
1. Construction Schedule
 2. Contractors identification of; safety officer, foreman, and project manager with beeper and cell phone numbers shall be provided.
 3. Deliver Product Data sheets and Henry Technical Bulletins for specific conditions for all materials to be incorporated into this project and provide MSDS sheets to the owner.
 4. Review equipment and material storage requirements at the job site.
 5. Review Emergency Response (911) and safety precautions to be implemented for this project. This shall include;
 - a) Delineation of building entrance and exits.
 - b) Scaffolding and ladder stations.
 - c) Overspray protection.
 - d) Trash and debris removal.
 - e) Material Storage.
 - f) Empty container storage.

PERMAX[®]

POLYURETHANE ROOFING INSTALLATION MANUAL

SECTION 4

DETERMINING R-VALUE

- A. Project specifications may include R-Value requirements as a part of the overall design or bid documents. R-Value may be determined from K Factor. $1 \div \text{K-Factor} = \text{R Value}$

Material:	(R) Resistance	Material:	(R) Resistance
Air Films;		Vermiculite	2.08
<u>Outside Surface</u>		Building Board;	
Winter – Heat flow up – 15 mph	.17	Cement Board	0.25
Summer – Heat flow down – 7 ½ mph	.25	Gypsum or Plaster Board ½”	0.45
<u>Inside Surface</u> (still air)		Plywood ½”	1.25
Winter – Heat flow up	.61	Hardboard, 7/16 siding	0.67
Summer – Heat flow down	.92	Particleboard, medium density	1.06
Air Space;		Masonry Materials, Concrete;	
Dead Air (not vented) ¾”	0.76-1.27	Cement mortar	0.20
(not less than 4”	0.80-1.35	Stucco	0.20
Decks;		Brick, common	0.20
Structural Concrete (R=.08/in) 4”	.32	Clay tile 4”	1.11
6”	.48	Clay tile 8”	1.85
Gypsum (R=.60/in) 2”	1.20	Plastering Materials;	
Lightweight Concrete		Cement Plaster, sand aggregate	0.20
(1:4 mix R=1.11/in) 2”	2.22	Gypsum Plaster	0.18
(1:6 mix R=1.32/in) 2”	2.63	Siding Materials;	
Wood Decks		Cement Shingles 120#	0.21
3” nominal plank 2-5/8”	3.28	Roofing Materials;	
2” nominal plank 1-5/8”	2.03	3-ply BUR Fiberglass	0.33
1” nominal plank 25/32”	.98	72# Fiberglass Cap Sheet	0.15
¾” plywood	.94	Asphalt Shingles	0.44
½”	.63		
Sheet metal	0.00		
Insulation;			
Cellular Glass	2.50		
Glass Fiber	3.50		
Expanded Perlite	2.56		
Expanded Polystyrene Bead Board	3.57		
Rigid Urethane Foam Board	6.0		
Sprayed Polyurethane Foam	6.50-6.90		
Foam Glass	2.86		
Mineral Fiber with Resin Binder	3.45		
Mineral Fiber Board	2.94		

** See ASHRAE Handbook For Additional Information

PERMAX[®]
POLYURETHANE ROOFING
INSTALLATION MANUAL

SECTION 5

STORAGE and HANDLING

- A. Polyurethane foam and coating should be stored out of direct sunlight and protected from excessive heat or cold. Freezing temperatures can render materials unusable. Excessive heat can change the polyurethane foam's reactivity and/or cause spills when opened under pressure.
- B. Do not heat 'B' drums with band heaters unless specifically designed as low mass and suitable for 245fa blown materials. Do not re-circulate 'B' material through the main heaters the, as it will froth when heated to over 60°f and when pressure is released.
- C. When pouring-up chemicals always wear approved clothing, chemical gloves, full face shield, rubber gloves, and approved respirators.
- D. All emptied containers shall have the bungs reinstalled and disposed of in the appropriate manner as soon as possible. Do not reuse empty containers.
- E. Do not smoke or weld during the loading, pouring, or application of polyurethane foam or coating materials.

PERMAX[®]
POLYURETHANE ROOFING
INSTALLATION MANUAL

SECTION 6

QUALITY CONTROL / DAILY REPORTS / INSPECTIONS

- A. A copy of the construction specification shall be in possession of the roofing contractor foreman at the job site at all times. The contractors own quality control manual and approved details shall be available at the job site.
- B. **Contractors Reports;**
1. **Project Materials Inventory Form;** (copy attached) this form shall be completed and delivered to the Owner when major material items are delivered to the job site along with copies of shipping documents from the supplier as a part of the Daily Report or back-up for material billing purposes.
 2. **Daily Report;** (copy attached) shall be completed and maintained on a daily basis. The inspector of record or material manufacturer shall have access to these forms.
 3. **Permax[®] Perma-Plus Labor and Materials Warranty Pre-Notification;** The contractor shall prior to job start complete and deliver to RTC the **Permax[®] Perma-Plus Roofing System Warranty Pre-Notification Form #106** including a copy of all plans and specifications. Upon approval the contractor shall be notified in writing and a warranty number assigned for this project.
 4. Upon completion of the project, if a RTC Warranty is required, the appropriate inspection request forms (WR-105 or WR-106) shall be submitted. Contact the Henry Warranty Department, phone 866-787-6947, Fax 800-586-9919, E-mail warrantyadmin@henry.com if you have any questions regarding these forms.
- C. **Progress Meetings;**
1. Progress meetings shall be scheduled weekly or as necessary for the scope and complexity of this project.

2. Attendance; owners representative, consultant, job superintendent, roofing contractors project manager, roofing contractors superintendent/foreman, material manufacturer, project inspector.
3. Minimum Agenda:
 - a. Review of work in progress
 - b. Schedule
 - c. Problems and corrective action
 - d. Request for Information (RFI)
 - e. Interface with other trades
 - f. Maintenance of quality and work standards
 - g. Safety

D. Inspection;

1. The Manufacturer (RTC) shall be allowed site access to make periodic inspections during any phase of the roofing installation process. Additionally the manufacturer shall have access to copies of the contractor's daily reports if requested.
2. A representative of the Coating Manufacturer (RTC) shall inspect the roof after completion to assure that the detail work at the protrusions, drains, parapets, and edges has been completed in conformance with the specifications and accepted industry practice (including the requirements of the specified manufacturers warranty) and project details.
3. The Owner may retain, at their own expense, the services of an **Independent Inspection Service** to make a final inspection and report of the completed work. Owner will declare and identify the independent inspector at the Pre-Construction Meeting. This inspection will review the specifications and determine if all work and details meet or exceed the specifications. Slit samples of the protective coating and foam cores shall be taken to determine if minimum requirements have been met.

E. Inspection Forms;

1. Upon project completion, or as sections or segments of larger projects are completed, the contractor shall inspect the finished work area and complete the attached forms. These forms shall be available to the Manufacturer if required;

- a) Material inventory forms
- b) Daily report forms
- c) Final inspection form

PERMAX[®]
POLYURETHANE ROOFING
INSTALLATION MANUAL

SECTION 7

ACCEPTABLE ROOF DECKS AND SUBSTRATES

A. New Construction Decks;

1. Plywood; minimum 15/32" 4-ply Struct I
2. Corrugated galvanized metal decks. (See attached profiles)
U.L. Fire Classified; No. 161
U.L. Fire Classified; No.181
3. 'B' Deck UL Fire Classified No. 206
4. Standing Seam Metal Decks (specs. available from RTC)
5. Structural concrete
6. Lightweight Concrete

B. Existing Membranes;

1. Gravel surfaced BUR (gravel removed)
2. Fiberglass Capsheet
3. Modified Bitumen (granulated)
4. Smooth surfaced BUR (Fiberglass or rag felts top mopped)
5. Fiberglass Shingles
6. Concrete Tile
7. EPDM
8. PVC
9. Single ply (others)

C. Base Sheet and Fasteners;

1. Base Sheet; A base sheet if required shall be 72 Lb. fiberglass, mineral surfaced cap sheet as manufactured by John Manville, GAF, ConGlass or equal.
2. Nailable decks; The fasteners shall be 1-inch, square head, ring-shank nails as manufactured by Simplex or equal with sufficient length to penetrate sheathing or embed a minimum 1-inch into sheathing.
3. Mechanical Fasteners and Plates; Screws shall be No. 12, coated, self-tapping screws of sufficient length to penetrate the existing BUR and insulation with 1 inch penetration (minimum) into the substrate. The plates shall be 2 inch square, coated steel

plates. The screws and plates shall be as manufactured by Olympic, DeckFast or equal.

4. **Base Sheet Attachment;** Wood decks where BUR materials have been removed and require a base sheet shall be fastened as follows. A 72 lb. Mineral surface cap sheet shall be mechanically attached using 1 inch, square head nails. End laps shall be nailed at 4 inches on center. Side laps shall be nailed at 9-inches on center with 2 rows staggered 12-inches in from the side laps and nailed at 16-inches on center.

D. Recover Board/Fire Protection Board

1. A recover board or fire protection board between a wood deck using diagonal sheathing or insulation board if required shall be Georgia-Pacific Corporation ¼-inch Dens-Deck 4' x 8' sheets. Dens-Deck may be installed parallel or perpendicular to sheathing, stagger all joints. DensDeck must be primed.
2. Fire Resistance; Flamespread O, smoke development O, when tested in accordance with ASTM E-84. Noncombustible when tested in accordance with ASTM E136.
3. **Recover Board Attachment;** (Wood, Concrete, or Steel Decks) Dens-Deck must be installed with mechanical fasteners and plates specified in accordance with FM Wind Uplift requirements. Some metal decks and concrete substrates may use adhesives for attachment.

E. Metal Roofing Decks or Panels.

1. The following metal decks and panels may be encountered. Some of these are Classified by Underwriters Laboratories Inc. as "Fire Classified" TGKX;
 - a. UL Construction No. 136, Typical, (truncated rib)
 - b. UL Construction No. 181, Typical, (corrugated)
 - c. UL Construction No. 206, 'B' Deck, Typical (fluted)

Typical Ribbed or Corrugated Roof Panels

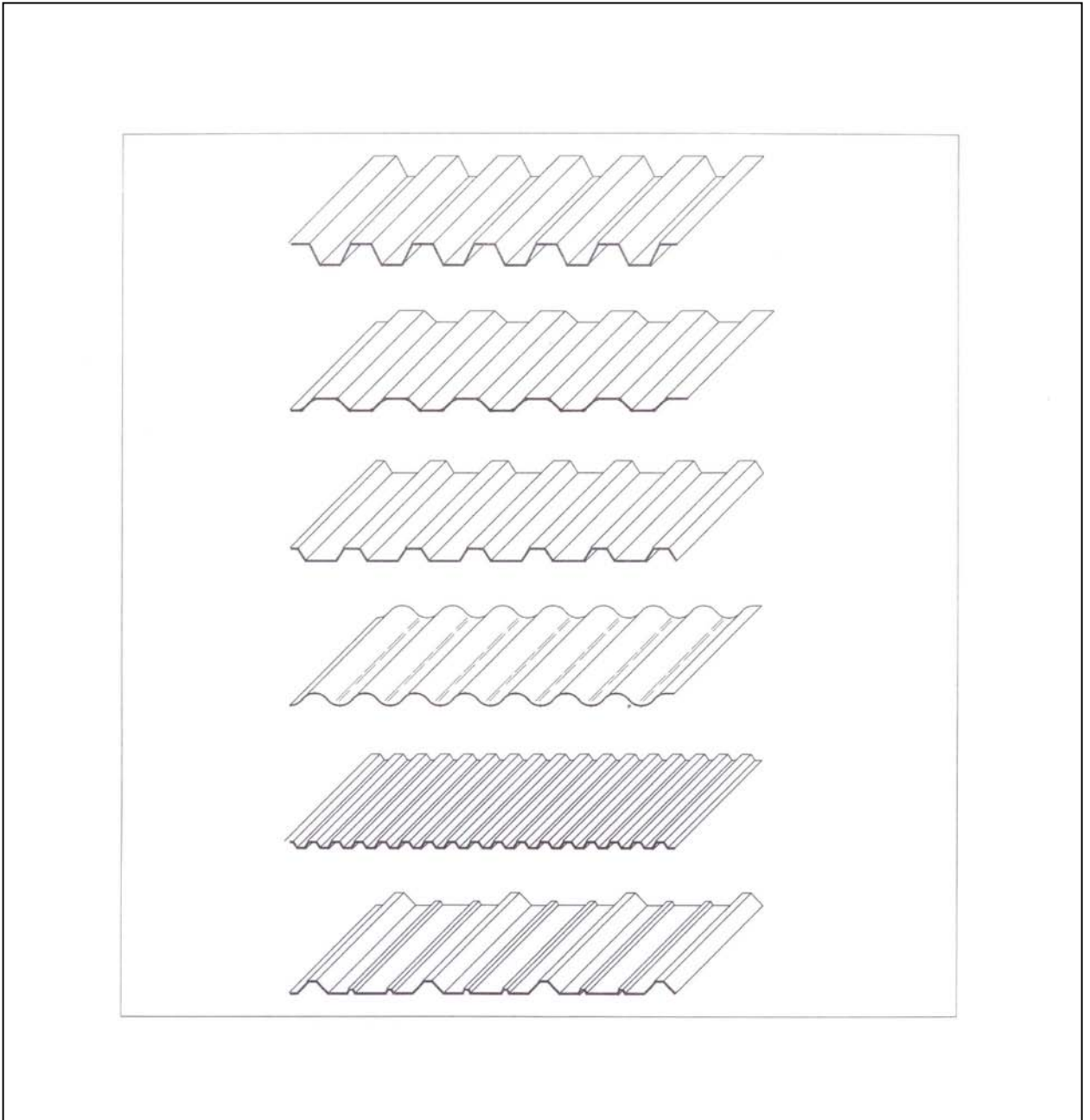

Some panels may be constructed of aluminum or galvanized steel. All metal deck panels will require priming. Some factory painted metal panels, when new, should be water blasted clean and tested for adhesion. A bonding primer may be necessary.

Standing Seam and Special Snap-Lock Decks

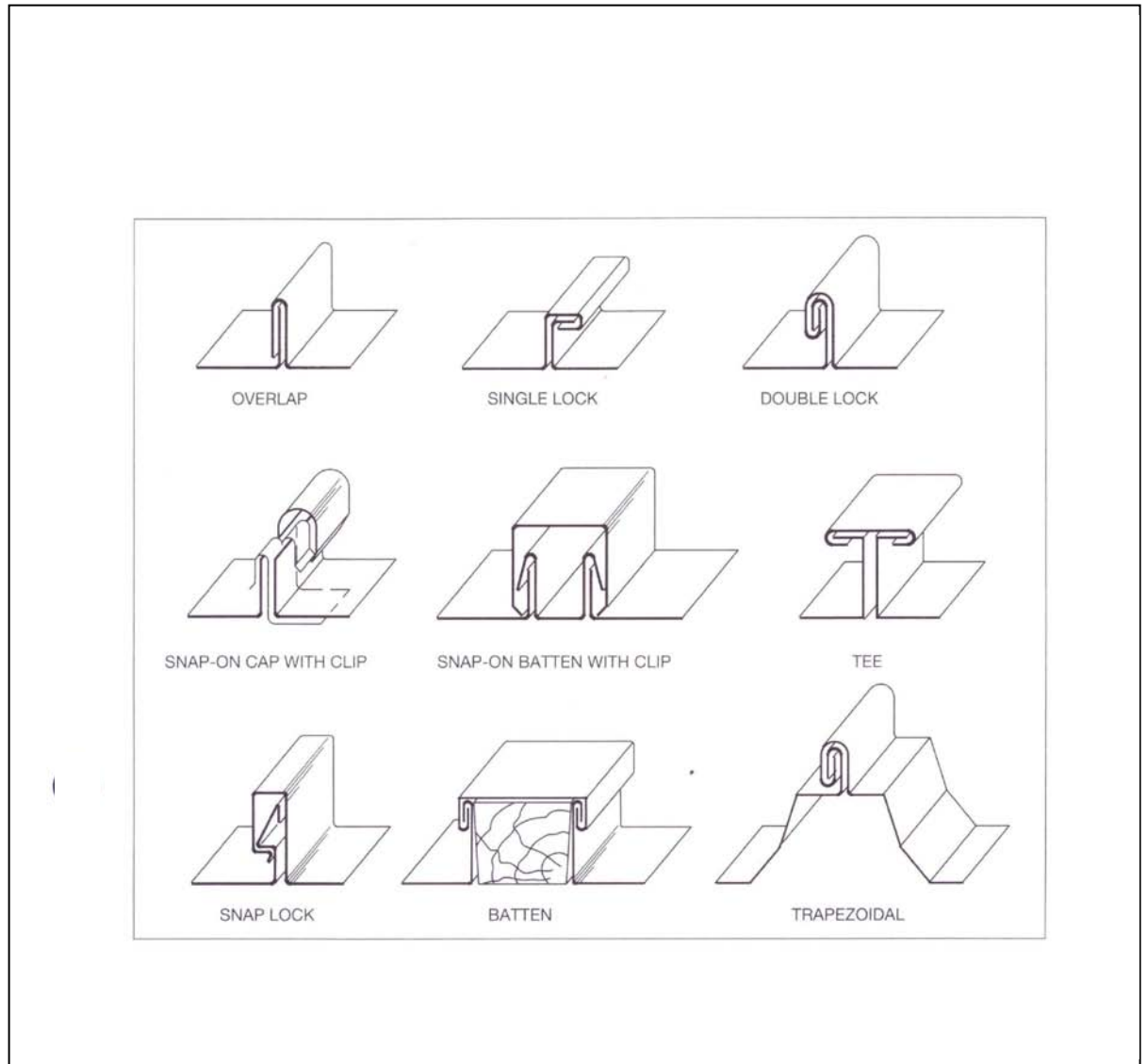

Some panels may be constructed of aluminum or galvanized steel. All metal deck panels should be primed if direct foam application is installed. It may be cost effective to overlay these decks with plywood or insulation board. Insulation board filler strips may be fitted into special deck configurations. Mechanical attachment or approved adhesives may be used. Insulation boards should be primed.

PERMAX[®]
POLYURETHANE ROOFING
INSTALLATION MANUAL

SECTION 8

ROOF DECK PREPARATION

**A. Gravel Surfaced BUR, Fiberglass Cap Sheet,
Smooth Surface BUR**

The existing roof condition of the existing Built-Up-Roof must be determined in respect to; attachment, trapped moisture, ridging, blistering, number of roofs present, ACM, and local code requirements for re-cover which will dictate the roof preparation procedures as follows;

1. All blisters in the built-up-roofing (BUR) less than 6 inches in diameter shall have gravel surfacing spudded from blister area and shall be slit and fastened to the roof deck using appropriate length square head nails or screws and plates. Flashing cement may be used, if roofing will relax and conform to deck. On non-nailable substrates blisters may be removed to deck. All blisters larger than 6 inches shall be cut and removed from the deck.
2. Ridging of felts caused by expansion and contraction, improper attachment, or ridges caused by BUR slippage, shall be cutout to provide a smooth flat surface for re-roofing. Spud gravel surfacing from edges to provide a smooth surface for fasteners to seat or to install a membrane over these areas. Re-attach both side of the ridge with square head nails or screws and plates. If deep voids are left from the vacant ridge they may be filled with spray foam and ground level or install a membrane over these areas.
3. Areas of built-up roofing with insulation board which has been crushed or moisture is detected must be removed. These areas after removal, and when dry, must be leveled prior to re-roofing. DensDeck, Polyiso Insulation, or Spray in Place Polyurethane Foam may be used. Trim and/or feather the filler material to match the original roof level. The perimeter of the removal area must be re-attached to the substrate using screws and plates 6-inches O.C.

B. Gravel Surfaced BUR

Gravel Removal;

1. Dry Vacuum; Remove all loose gravel, dirt, and debris from all roof surfaces by power vacuuming. Repairs and re-attachment of the membrane should be done prior to power brooming and re-vacuuming. Power broom all roof areas and re-vacuum all surfaces until clean.
2. Wet Vacuum; Remove all loose gravel, dirt, and debris from all roof surfaces by power wet vacuuming which includes a water blasting to dislodge dirt and debris from a single vacuum head. Temporary repairs to roof defects may be necessary prior to this operation to prevent water intrusion into the roof system.

C. Tear-off;

1. Remove all existing built-up roofing, base flashing, pitch pans, parapet wall coverings, and insulation to the substrate. Some specifications may require removal of specific BUR coverings (2nd and/or 3rd roofs) leaving the original membrane as the recover surface. Excess asphalt remaining on the substrate in the form of nodules shall be removed by spudding. All mechanical fasteners shall be removed or ground flush with substrate. Repair or re-place any deteriorated decking or sheathing. It may be a code requirement to have wood decks inspected for proper nailing prior to covering over the deck. It is recommended that only as much roof area be removed in one day as can be replaced that same day to prevent any weather caused damage. In some geographical areas, and depending on the time of the year, it may be necessary to “water block” or provide a daily “night seal” to protect the new roofing from rain.

D. Single Ply, Metal Roofs;

1. These surfaces shall be power washed to remove all dirt, debris, and oxidation. All surfaces shall be primed with an appropriate primer. It is necessary to consult with RTC on any Single Ply surface being considered for new SPRS prior to installation.
2. Attachment consideration of Single Ply and Metal roofs must have adequate mechanical attachment to be considered for sprayed polyurethane foam roofing. All

loose-laid or ballasted single ply roofs must be re-attached a minimum of 1- fastener every 2 sq. ft. or covered with DensDeck and mechanically attached per the manufacturers recommendation.

PERMAX[®]
POLYURETHANE ROOFING
INSTALLATION MANUAL

SECTION 9

EDGE METAL

- A. Fabricate new 24 gauge Bonderized (**galvanized steel must be etched and primed**) metal foam stop with 1-inch rise above deck, minimum 4-inch flange on roof, and minimum 4-inch face. Edge metal shall be install at all eave edges and parapet walls.

- B. All new edge metal shall be installed with a drip edge and return and shall be trimmed to provide a 2-inch interlock union. Edge metal shall be set into a bed of elastomeric caulking such as Henry 900 Construction Sealant, Vulkem 116, or Sika 1a materials. Attachment of edge metal to deck or wood nailer shall be with galvanized composition roofing nails with length long enough to penetrate a minimum of 1-inch into the sheathing with two rows staggered 4-inches on center. If “gun nails” (Senco or equal) are used **all** nails must be set tight against the metal. Screws may be substituted for nails with fastening pattern 6-inches O.C. All joints and laps shall be buttered with elastomeric caulking such as Henry 900 Construction Sealant, Vulkem 116, or Sika 1a materials. Perimeter edge metal attached over concrete substrates shall be attached over a treated wood nailer mechanically fastened to the substrate, or if attached directly to the concrete shall be fastened using “TapCon” concrete screws, “Raul-Spike”, or “Z-Mac” fasteners on 9 inch centers. Holes shall be pre-drilled, **powder actuated fasteners** shall not be allowed. All metal laps shall be buttered with elastomeric caulking as specified above.

- C. Existing low-rise edge metal may remain if new edge metal can be installed over the existing edge metal rise and the new face will cover the existing by a minimum of 1-inch. Gravel shall be scarified (spudded) from roof edge a minimum of 6-inches from edge to provide a smooth flat surface for 100% contact of new edge metal and roof surface. New edge metal shall be set into a bead of elastomeric asphalt such as Henry 209.

- D. Existing high-rise edge metal may remain if rise and face are cut off with sawzall. Gravel shall be scarified (spudded) from roof edge a minimum of 6-inches from edge to provide a smooth flat surface to install the new foam stop. New foam stop metal shall be set into a bed of elastomeric asphalt such as Henry 209.

- E. If existing gravel stop is rusted, damaged, or deteriorated cut built-up roofing 4-inches behind the back edge of existing edge metal and remove existing edge metal, cleats, and all fasteners. Spud gravel surfacing from immediate edge and re-fasten BUR with square head nails 4-inch O.C. or screws and plates 9-inch O.C. New foam stop to be installed directly to roof edge per paragraph B above.

PERMAX[®]
POLYURETHANE ROOFING
INSTALLATION MANUAL

SECTION 10

HVAC PLATFORMS

A. Field Assembled HVAC Curbs

1. Fully enclosed (boxed) platforms constructed from 2" × 8" (minimum) lumber with 1/2 inch CDX Struct I plywood top shall be fabricated. The plywood top shall not span more than 16-inches or 2 x lumber shall be added for support. The platform shall be toe-nailed into existing roof joists or metal angle brackets lagged into the platform and roof deck for attachment. **The finished grade of the top of the platform shall be 8-inches (minimum) above the new roof level.** A layer of Henry "Ruftac" or Modified Bitumen "Peel and Stick" membrane roofing shall be bonded over the plywood top of the platform and turned down at the edge a minimum of two inches with corners split, folded and mechanically attached. A new 24 ga. Galvanized, seamless sheet metal cover shall be installed over the platform. Where large platform covers are required all seams shall be soldered or constructed with a 1 1/2 inch minimum standing seam. **Caulking of the seams shall not be acceptable.** The new metal cover shall be 2 inches larger than the wood curb on all sides with a 2-inch X 60° degree turndown and ¼-inch hem.

2. Prior to setting the new platform into place spray apply a minimum of two 2-inch applications of polyurethane foam insulation into the underside of the platform to provide insulation, structural strength, and sound deadening. It may be necessary to foam the vertical sides of the platform prior to setting it into place if clearance on all four sides is not sufficient for proper foaming. Polyurethane foam tying the platform into the roof shall have additional material applied to provide slope so water does not pond around the platform. **Do not foam the sheet metal cover into the roof.**

B. Pre-Engineered/Manufactured Curbs

1. New galvanized steel manufactured curbs shall be graded and installed by others to accommodate downdraft or side discharge HVAC units. **The finished grade of the top of the manufactured curb shall be 8-inches (minimum) above the new roof level or nailers shall be added.** It is important that if the new curb is supplied with a 2" x 2" nailer under the mounting flange that it be removed prior to sealing the curb into the roof with polyurethane foam and protective coating. The mitered edge joint of the metal platform shall be caulked or a galvanized edge cover be installed prior to installation of the unit.

C. **HVAC Ducts;**

1. All duct work shall receive a minimum of one inch of polyurethane foam. **NOTE: The duct walls at the roof penetration shall receive 1 inch of foam on all four sides with a smooth flashing transition to both the roof and the A/C platform sides.** (This may require either disassembly of the duct work or moving the A/C unit prior to foaming.) Do not apply foam to canvas connector or vibration isolation boot between unit and ducts.

D. **Electrical and Connections;**

1. If line voltage, low voltage, gas line, and condensate connections are new and only stubbed-out they must be a minimum of 12-inches above the finished grade of the roof and supported at the roof deck. **NOTE: ALL ELECTRICAL CONNECTIONS AND GAS CONNECTIONS MUST BE DISCONNECTED PRIOR TO RAISING THE UNIT AND RECONNECTED AND TESTED AFTER THE UNIT IS RESET.**
2. All conduit and gas lines must be raised off the roof. After the roof has been foamed, the conduit can be reset on 2" x 4" redwood set on top of the foam with walk pads under the wood. **The old conduit supports shall not be reused.**

PERMAX[®]
POLYURETHANE ROOFING
INSTALLATION MANUAL

SECTION 11

ROOF DRAINS and SCUPPERS

A. Roof Drains;

1. All internal roof drains shall be flushed with water to insure that the drains are clear to the discharge level prior to starting the roofing work.
2. Remove the clamping ring from the drain bowl. Remove all broken bolts from clamping rings, re-drill and tap holes as necessary for replacement with new bolts. Remove all BUR materials from the drain bowl flange and for a minimum distance of 18-inches around drain. Fasten the edge of the remaining BUR membrane materials to the roof deck with appropriate fasteners. Apply a bead of elastomeric caulking to the drain bowl clamping ring contact areas and refasten the clamping ring with new bolts. Remove excess caulking from inside of the drain bowl and clamping ring. Mask the inside of the drain and spray a “water block” from the deck to the top of the clamping ring. Grind excess insulation flush with the top of the clamping ring. The elastomeric coating shall be applied and “back rolled” in a “picture frame” fashion to achieve double the specified field thickness of coating around the water entry area. Flush drains (a second time) with water to insure that the drains are clear to the discharge level after all roofing work is completed. The strainers shall be locked over the drain opening (use existing or new locking rings or install new hardware and fasteners as necessary). All internal drains shall be fitted with appropriate strainers or leaf catchers. If new strainers or catchers are required (or missing), they shall be metal. **Plastic strainers and leaf catchers shall not be used.**

B. Scuppers;

1. All scuppers shall be opened to comply with local codes regarding the size of the water entry opening. **NOTE: Insure that all existing scuppers are open and have not been covered with other roofing materials.** Remove all BUR materials from the entire scupper and flange. Roofing

may be removed from scupper area to provide drainage at scupper area. BUR must be mechanically attached to roof deck using fasteners with sufficient length to penetrate the membrane and minimum 1-inch penetration into substrate 4-inches O.C. Clean retained metal components and prime. Rusted metal shall be replaced to match existing or better. Enlarge scupper openings as necessary. Reseal scupper and flash with foam.

PERMAX[®] POLYURETHANE ROOFING INSTALLATION MANUAL

SECTION 12

PRIMER SELECTION and APPLICATION

A. Substrate Primer;

1. Plywood
2. Existing Fiberglass Cap Sheet
3. Vacuumed Gravel Surfaced BUR
4. Modified Bitumen (granulated)
5. Smooth surfaced BUR (Fiberglass or rag felts top mopped)
6. Fiberglass Shingles
7. Concrete Tile
8. Painted Metal Panels

Primer for the above substrates shall be **RTC Acryprime-Sustrate Primer** an acrylic based primer to be applied at a nominal rate of ½-gallon per 100 sq. ft. Primer must be dry and be cured before application of polyurethane foam.

B. Substrate and Edge Metal Primer;

1. Galvanized Metal Panels
2. Aluminum Metal Panels
3. Galvanized Foam Stop Metal (edge metal)
4. Stainless Steel

Primer for the above substrates and/or edge metals made from the above materials shall be primed with Sherwin Williams DTM[®] Wash Primer, Krylon Industrial Products Water-Reducible Wash Primer, or Cardinal Pretreatment Wash Primer 4860-Series.

C. Substrate;

1. Structural concrete
2. Lightweight Concrete

Primer for the above substrates shall be **RTC Acryprime-Sustrate Primer** an acrylic based primer to be applied at a nominal rate of ½-gallon per 100 sq. ft. Depending upon the density of the concrete substrate **RTC-Urebond V Penetrating Epoxy Sealer** may be a more suitable primer. Test patches of primers should be

installed if adhesion to the substrate is questionable and contact RTC directly at (800-729-0795).

PERMAX[®] POLYURETHANE ROOFING INSTALLATION MANUAL

SECTION 13

FOAM PROCESSING / TROUBLE SHOOTING

- A. Polyurethane foam materials using 245fa blowing agent should be processed in modern equipment specifically designed for this use. Main heater settings should be set at the approximate settings;

'A' Heater Setting	100°f -120°f
'B' Heater Setting	120°f -130°f
Hose Heater Setting	115°f -120°f
Spray Pressure	900-1300 psi*

*Pressure depends on tip size and design of spray gun.

Always wear the proper protective clothing and respirator protection when spraying, loading, or pouring-up polyurethane foam and protective coating systems. Respirator cartridge change-out must be followed and change date recorded. All safety precautions shall be observed during the start-up, operation, and shutdown of all high-pressure spray equipment.

Certain spray guns have specific mix and pattern characteristics, which can affect the end product. Some guns provide better mix, better working spray pattern, higher material yield when used for roofing applications than when used in building envelope type spray work. Generally a roofing application would place the spray gun 24"-30" from the deck and provide a full round spray pattern aimed at a 90° angle to the roof deck. Very narrow patterns where the gun must be 48" or further from the deck should be avoided. These patterns will create a rougher surface profile and less foam yield. Consult your RTC Representative for the best combination for your type of work.

Caution; Depending upon the spray gun tip size and output capacity of the equipment, it is important that the spray gun and proportioner be matched to output capacity. Additionally, LED settings may give false readings. It is advisable to install thermometers on the outlet side of the proportioner so "actual" temperatures may be monitored. This will help in "fine tuning" for spray pattern and optimizing product yield. Always "test spray"

foam insulation into a bag or on cardboard at start-up or after lunch breaks. Check for proper pattern, mix, cure, and cell structure.

- B. Job site storage of foam and coating is very important as viscosity builds as liquids become colder. Foam machines have limitations to the heating capacity of colder materials to reduce viscosity to create spray atomization and proper mixing. If materials are too cold they must be heated or smaller tips in the gun used to reduce output so these materials stay in the heaters long enough to attain proper temperature. Contractor storage in severe climates, hot or cold, can require insulated storage rooms with added heat or air conditioning to maintain correct temperature conditions for these materials.
- C. If a pulsation in the spray pattern should occur during spraying, the first corrective action is to determine if the cause is from a lack of supply from the feeder pumps, or a restriction of flow at the spray gun. Determine if the problem exists in the 'A' side or the 'B' side. Cleaning the gun, cleaning the gun filters, cleaning the filters at the proportioner are quick and easy primary fixes. Isolation of feed supply and determination of proper power, air supply, and flow generally solve the problems. Check hose heat continuity. Check outbound material temperatures as if they do not achieve "set" temperatures you cannot spray properly and attain proper texture and/or achieve design yield of material.
- D. Off-Ratio Foam must be removed and never sprayed over. 'A' rich foam is dark in color, doesn't rise properly, and is friable or brittle. "B" rich foam will be lighter in color, soft or spongy, and smell like the "B" side. Generally when an off-ratio condition occurs the spray pattern of the material is affected adversely and all spraying must be stopped. Further spray testing should be performed upon plastic or some other disposable material, not on the roof deck.
- E. **Calling for HELP!** If you cannot solve these problems on your own then call your RTC sales representative (800-729-0795) or your equipment supplier. He will help you, or get you to someone who can help. You must have **all** of the following information ready so your problems can be analyzed and trouble shooting can be performed;
 - 1) Type Proportioner
 - 2) Length of spray hose
 - 3) Gun type and tip size
 - 4) RTC material being used with batch number
 - 5) Type feeder pumps, length and size of feeding hose
 - 6) 'A', 'B', Main Heater settings, and Hose Heat settings
 - 7) Pump pressure setting

- 8) Pressure gauge readings; static and dynamic readings
- 9) Temperature of materials in drums
- 10) Output temperature of materials at machine (actual not LED readings)
- 11) Ambient air temperature
- 12) Surface temperature and type substrate
- 13) What type problem are you having

With the above information we can generally help trouble shoot your problem and with some gun cleaning and parts changing get you spraying again.

PERMAX[®]
POLYURETHANE ROOFING
INSTALLATION MANUAL

SECTION 14

APPLICATION OF POLYURETHANE FOAM

A. Environmental Conditions;

1. Wind velocity shall not exceed 12-15 miles per hour. Windscreens and enclosures may extent this limitation. The application of foam over overspray areas may create blisters in the top pass of the foam. If the spray application is performed inside a movable or stationary tent it will be a requirement for the foam applicators and second men inside the work area to have pressure fed fresh air.
2. Application of spray foam shall not proceed if ambient temperature is less than 50 degrees Fahrenheit or if the substrate temperature is less than 60 degrees Fahrenheit and rising. Cold temperatures can cause surface friability where subsequent foam passes may delaminate. Use smaller output tips and avoid thin passes to prevent this condition.
3. Spray foam is not to be applied over moist substrates or where rain or inclement weather is imminent.
4. The field of the polyurethane foam shall be applied in minimum ½-inch lifts to the minimum thickness specified below. Polyurethane foam may be gradually tapered to edge metal (1-inch rise metal), roof drains, and scuppers from a distance of up to three feet from edge or drain outlet. Polyurethane foam may be applied to greater thickness than ½-inch per lift if all other requirements and conditions are met. The maximum polyurethane foam thickness generally shall not exceed 4-inches. Additional thickness is allowed if cure time is given between passes when building excessively thick areas. Low areas over 100 sq. ft. in size and greater than ½-inch deep shall be filled with foam to match the surrounding grade and prior to the application of the specified thickness of foam. Roofs with excess ponding water conditions, as noted above, shall be corrected to be eligible for Permax[®] Warranty coverage. Channeling of the foam insulation to roof drains is not permitted. All parapet

walls and ductwork shall receive a minimum of 1-inch of foam and the specified protective coating.

5. Detail foam work such as edges, projections, curbs, pipes, HVAC curbs, and parapet walls are generally sprayed using a smaller output tip or spray gun prior to spraying the field application. Building-up low areas or cricketing shall also be sprayed first, then the field application. This procedure will reduce the lap lines in the foam application and result in a smoother profile.

B. Application Thickness;

1. The field of the polyurethane foam shall be applied in minimum ½-inch lifts to the following minimum thickness. Added thickness to the following minimums may be specified as required. K-Factor 0.155 or R-Value of R 6.45 per inch may be used to increase roofing R-Value.

a.	Cap Sheet	1-inch minimum
b.	Gravel Surfaced BUR (vacuumed)	1 ½-inch minimum
c.	Corrugated Metal	1 ½-inch minimum
d.	HVAC Ducts	1-inch minimum
e.	Parapet Walls	1-inch minimum
f.	Wood Decks, (optional nailed base sheet)	1 ½-inch minimum
g.	Recover Board	1 ½-inch minimum

** The above foam thickness may not always be what is required by specific Building Departments, their requirements could recommend additional foam material.

Note: Freshly sprayed foam shall be allowed to set for 15 minutes before being walked upon.

2. Only as much area as can be brought to final thickness should be attempted in a day. At days end the termination point of foam insulation shall be primed (one pass, 3-4 feet wide) for overnight protection and to provide a dry surface for next days start-up spraying. Protection tarps (canvas) or roofing felts may also be installed over the tie-in area as temporary protection to expedite drying these areas for the next days spray work. **Phasing of the foam is strictly forbidden.** (Phasing is foam application on one day and coming back the next day or thereafter and applying another layer of foam. This procedure may lead to the development of blisters in time). If additional foam must be added after

the 24 hour period, the existing foam must be primed (see para. 2.01). a minimum of 1/2 inch of foam in a single pass shall be applied.

C. Slope to Drain;

1. Roof slope of ¼-inch in 12-inches (approximately 2%) is recommended and may be a minimum requirement at some building departments where re-roofing permits are obtained. Minor sloping, cricketing, and building wash-backs may be done with spray foam. Some deck sloping may be done with spray foam in areas where 3" to 1" or 4" to 1" sloping can be accomplished.
2. Where dead flat roof decks have been designed and re-sloping is required with long runs, it is recommended that a tapered polyisocyanurate board or polyisocyanurate board and tapered edge strips be incorporated to provide the major slope. These boards must be faced (both sides) with an asphalt saturated felt paper and be mechanically attached with screws and plates to meet wind uplift requirements for the building zone you are working in. The use of **EPS** board stock is not allowed.
3. All board stock must be primed with Acryprime-Substrate Primer. The spray polyurethane foam may be applied directly over the cured primer and properly attached board stock to a minimum thickness of 1 ½-inches.

D. Application;

1. If construction trades require roof sealing for new platforms, curbs, blocking, penetrations, etc. roofing mastic or wet patch **is not allowed**. Torch applied granulated Modified Bitumen materials are acceptable. The use of polyurethane foam may be used. The polyurethane foam may be applied to full thickness or as necessary to properly seal these areas. It must **always** be primed or base coated the same day to prevent oxidation or moisture contamination to the patch area.
2. The foam shall be free from bumps, pinholes and ridges. The surface shall exhibit a smooth or "orange peel" surface texture. "Popcorn" or "tree bark" surfaces shall be deemed unacceptable.

3. At the internal drain openings, grind the foam to a smooth slope for ease of water entry. New metal screens shall be provided if the original screens are broken or missing.

E. Quality Control;

1. Polyurethane Foam Thickness: Depth of the polyurethane foam shall be verified by the application Contractor prior to applying the protective coating. Acceptable minimum thickness shall be indicated on the roof plan on the Daily Report Form. Any areas found to be deficient shall receive additional foam to bring these areas up to minimum thickness. Material manufacturer shall verify polyurethane foam thickness at final inspection.
2. If “slip-sheets” are needed to waterproof under piping or other obstructions the following method shall be used. The specified foam thickness shall be applied to 1/4 inch DensDeck and positioned under the obstruction. Full edge attachment shall be accomplished using screws and 2-inch steel coated plates, 6-inches on center with screw length sufficient to penetrate the roof deck (**NOTE:** Leave a 4-inch gap between the end of the sheets, do not “butt-joint.” Foam a “tie-in” in the gap and trim the excess foam). If the roof deck is concrete then “Tub-Loc”, “Zonotite”, or “Rawl Spike” fasteners shall be used. Foam shall be applied to the edges of the slip sheet and adjoining roof area and the “tie-in” ground smooth if the profile is irregular. All trimmed or ground foam shall receive additional coating.

F. Foam Texture Surfaces;

1. The foam applicator should always attempt to apply the foam with the least amount of texture, lap lines are generally textured. The more texture in the foam application increases the coating gallonage requirements to provide the specified coating dry film thickness (DFT). The following measures may be used to reduce foam texture;
 - a. Order and install the right spray foam reactivity for the ambient air temperature you are working in.
 - b. Always adjust the foam proportioner to provide the highest quality spray foam, which is generally the least textured. Proper heat settings and mix pressure are critical for optimum results.
 - c. Foam detail work first
 - d. Build low areas first

- e. Spray field after detail work to reduce lap lines
- f. Use wind screens
- g. Apply foam so wind does not blow over previously foamed areas
- h. It is a requirement for the contractor to apply the specified minimum gallons per 100 sq. ft. to the roof, but the roof will be inspected and the dry film thickness of the roof will be measured. Additional coating may be required if foam texture is excessive and the DFT is short of the Specifications or Warranty requirements.

FOAM SURFACE TEXTURES

Foam Texture; **Smooth**

- ✓ Relatively Flat surface
- ✓ Most Desirable Surface
- ✓ 3% - 5% Additional coating Requirement
- ✓ Lap lines in foam spray will be at least one degree rougher in texture requiring additional coating



Foam Texture; **Orange Peel**

- ✓ Texture is compared to the Skin of an Orange
- ✓ Acceptable for Coating
5% - 12% Additional coating Requirement
- ✓ Lap lines in foam spray will be at least one degree rougher in texture requiring additional coating



Foam Texture; **Coarse Orange Peel**

- ✓ Acceptable for Receiving Coating
- ✓ Round Transition from Nodules to Valleys
- ✓ 15% - 25% Additional Coating Requirement
- ✓ Lap lines in foam spray will be at least one degree rougher in texture requiring additional coating



Foam Texture; **Verge of Popcorn**

- ✓ Roughest Texture Suitable for Coating
- ✓ Nodules are Larger than Valleys
- ✓ 25% - 50% Additional Coating Requirement
- ✓ Lap lines in foam spray will be at least one degree rougher in texture requiring additional coating



Foam Texture; **Popcorn and Treebark**

- ✓ Unacceptable for Coating
- ✓ Valleys form Sharp Angles Coating Slumps off of Nodules into Valleys
- ✓ Areas with less than 1% of Roof area, such as curb against wall, may be sanded and coated with roller to meet coating specification. Any field spraying resulting in these textures must be terminated and cause determined and rectified.



PERMAX[®]
POLYURETHANE ROOFING
INSTALLATION MANUAL

SECTION 15

FOAM BLISTERS, IDENTIFICATION and REPAIR

- A. Foam Blister Identification; It is assumed that the contractor is familiar with the polyurethane foam specified, and the specific equipment settings to achieve consistent blister free performance. Some polyurethane foam systems may be more tolerant of minimal weather conditions, excessive wind, or other marginal conditions.
1. Foam blisters are generally located in the top pass of the roofing system. These type blisters are generally classified as “cosmetic” and do not contribute or cause roof leaks. If left unattended they will eventually be broken by foot traffic, thus repairing these areas should be considered.
 - a. Top Pass Blisters may be contributed to various causes such as;
 - Thin pass application
 - Surface moisture present, perspiration or air line leakage
 - Inadequate surface temperature
 - Off ratio material application
 - Uncured pass line, (overspray)
 - Phased application (UV burnt surface)
 - b. Substrate Blisters may be contributed to various causes such as;
 - Off ratio foam application
 - Contaminated substrate
 - Improper substrate temperature
 - Deck moisture, moisture trapped in insulation
 - Overlaid membrane improperly attached or bonded
- B. Spray Polyurethane Foam Blister Repair
- a. Small blisters or small mechanical damage (6-inches or less) can be repaired with a compatible elastomeric sealant and top coating.

1. Cut-out the damage area leaving a 45° tapered edge. Remove all oxidized polyurethane insulation and deteriorated coating and airblast clean.
2. The repair area and adjacent surface must be clean, dry and free from oxidized polyurethane foam and/or coating. If the existing surface is granulated the immediate area around the repair should have the excess granules spudded (removed) from the repair area (using a nail bar or grinder) to insure a proper seal with the caulking and top coat material. Clean with stiff hand broom and/or air blast clean. Using a compatible sealant first apply the caulk, with proper tool, to the freshly cut outside edge with pressure to ensure bonding of the caulk into the cut polyurethane foam cells at this important edge. Apply additional caulking to the repair to insure that the final height, after cure, will remain higher than the surrounding area so that water will not pond over the repair. Do not install caulking in a single application to a thickness greater than recommended by the caulking manufacturer for proper cure. To avoid a blister in the caulking it may be a requirement to apply caulking to deep repairs in two separate applications or install a polyurethane plug to fill the void.
3. If a polyurethane foam plug is to be installed it should be cut 1/4-inch smaller than the repair area. It should also be a minimum of 1/4-inch thinner than the repair to allow for caulking thickness at the substrate and sealing over the top of the plug. Using a compatible sealant first apply the caulk, with proper tool, to the freshly cut outside edge with pressure to ensure bonding of the caulk into the cut polyurethane foam cells at this important edge. Apply caulk to the bottom and sides of the plug and place into the repair. Apply pressure to the plug, excess caulk should flow up and around the repair eliminating any voids. Apply additional caulk if needed or trowel-off the repair to insure that the final height, after cure, will remain higher than the surrounding area so that water will not pond over the repair.
4. All caulking repairs should be applied with pressure (using trowel) at the tapered edge to ensure a proper seal at this critical edge. Granules may be broadcast into the repair (if original roof is granulated) to assist bonding the top coat material to the caulking repair.

Coating repairs to small areas cure very rapidly so multiple coats may be applied the same day to achieve the original or greater coating thickness as specified.

- b. Large Blister Repairs (6-inches and larger), Roof Mounted Equipment Installation Area, and Off-Ratio Polyurethane Foam Repairs.
 - 1. Remove foam for equipment installation down to substrate. Any large blisters or off-ratio polyurethane foam down to sound polyurethane foam shall also be removed to the substrate. You must insure that the removal area goes beyond the affected blister or off-ratio area by a minimum of 6-inches. Cut-out the damage area leaving a 45° tapered edge. It may be a requirement to lightly grind or scarify the remaining polyurethane foam to insure a bondable surface. Air blast surface clean.
 - 2. The properly prepared foam area shall be primed with Acryprime-Substrate primer. The primer must be completely dry and cured before re-applying the polyurethane foam.
 - 3. The polyurethane foam shall be applied in minimum 1/2 inch passes to demolished or blistered areas and filled slightly above the existing grade. All excess material shall be ground or sanded to match existing grade.
 - 4. Apply a maximum of one gallon per 100 square feet of the specified coating and back roll as necessary to prevent the formation of pinholes. After the coating has completely cured, apply additional coating applications as required to achieve the coating thickness which was originally specified. Granules shall be broadcast into the final coating application if specified. All repairs should be completed with clean straight lines and should blend into the profile of the original roof.
- c. Mechanical Damage Repair
 - 1. Repair all mechanical damage by cutting away the damaged material or temporary repair materials and filing the void with a compatible elastomeric caulking material. The repair area and adjacent surface must

be clean, dry and free from oxidized polyurethane foam and/or coating. If the existing surface is granulated the immediate area around the repair should have the excess granules spudded (removed) from the repair area (using a nail bar or grinder) to insure a proper seal with the caulking and top coat material. Clean with stiff hand broom and/or air blast clean. Using a compatible sealant first apply the caulk, with proper tool, to the freshly cut outside edge with pressure to ensure bonding of the caulk into the cut polyurethane foam cells at this important edge. Apply additional caulking to repair to insure that the final height, after cure, will remain higher than the surrounding area so that water will not pond over the repair. Do not install caulking in a single application to a thickness greater than recommended by the caulking manufacturer for proper cure. To avoid a blister in the caulking it may be a requirement to apply caulking to deep repairs in two separate applications or install a polyurethane plug to fill the void.

2. Cracks, splits, slices in roof (mechanical damage caused by airborne debris) if found shall be repaired by routing or V-cutting a groove at the defect. Caulking repair shall be installed per the above.
3. All caulking repairs shall be top coated and/or granulated (if originally specified) using the coating and mil thickness as originally specified. If granules are applied to caulking only repairs, enough granules shall be applied and lightly pressed into the caulking to provide 100% coverage.

d. Coating Application over Exposed Sealant and Touch-up with Granules

1. Most caulking materials are moisture cure and are slow to dry, but the protective coating may be applied over caulking in thin coats the same day. Granules embedded into the caulking material will promote adhesion of the top coating material. Multiple coats should be applied to achieve the original coating thickness as specified.
2. If bare areas or shiners (thin or missing granules) must be corrected by adding coating and granules, mask-off or otherwise protect areas not to receive

materials. Small areas may be applied by roller application and granules broadcast by hand. Larger areas may be sprayed. All coating work must be done in blocked-off clean straight lines. A minimum of 1.5-2.0 gallons per 100 square feet is required to properly embed new granules. Granules must be embedded immediately into the coating material to reduce tie-in lap lines.

PERMAX[®]
POLYURETHANE ROOFING
INSTALLATION MANUAL

SECTION 16

PARAPET WALL APPLICATION

A. Parapet Walls:

1. Install 1-inch rise foam stop to parapet walls. All parapet walls shall be foamed over the top of the wall and to the outside edge. If a concrete block wall has a cement grout coping it must be demolished prior to installation of nailers or foam stop metal. If metal counter flashings exist, demolish them before foaming the wall. All wall surfaces shall be granulated.
2. If the existing coping is sound and shall remain, foam shall terminate under existing coping and a 'Z' bar flashing shall be installed using self-taping screws. All wall surfaces shall be granulated.

3. High Parapet Walls;

High parapet walls or lower roof/upper roof wall shall be properly sealed using one of the following methods;

- a. High parapet walls (above 5-feet) that incorporate a one piece counterflashing to terminate the roofing with a minimum of 8-inch base flashing above the roof line may be used to terminate the polyurethane foam and protective coating system. The existing counterflashing must ground clean of **all** paint and stucco and primed prior to foaming.
- b. High parapet walls (above 5-feet) that incorporate a one piece counterflashing to terminate the roofing that do not have a 8-inch minimum base flashing height above the roof line may be sealed into the parapet wall. The **entire wall** must be completely waterproofed with a minimum of 30 TDM of elastomeric coating or the exact coating as specified for the roof field application, which ever is greater.

B. Two-Piece Counterflashing;

1. High parapet walls (above 5-feet) that incorporate a two piece counterflashing to terminate the roofing with a minimum of 8-inch base flashing above the roof line may be used to terminate the polyurethane foam and protective coating system. Remove and save the counterflashing. After the polyurethane foam and protective coating have been installed and completely cured, re-install or replace the counterflashing as originally designed.

PERMAX[®]
POLYURETHANE ROOFING
INSTALLATION MANUAL

SECTION 17

APPLICATION OF ELASTOMERIC COATING

A. General;

1. Sprayed polyurethane foam must be protected from ultraviolet light in order to avoid degradation of the polymer. Coating also protects the foam from liquid, water and adverse weather conditions. Coating must be specifically formulated for use over polyurethane roofing foam.
2. Elastomeric coating shall be applied in a picture frame fashion and back-rolled at the roof perimeter. The coating shall be applied to **1.5 X** the specified thickness and finished with a “**HEAVY APPLICATION**” of roofing granules at these areas. This procedure shall ensure proper sealing of these critical areas.
3. Other areas where the foam has been ground shall also be back rolled and coated to **1.5 X** the specified thickness of elastomeric coating.

B. Spray Applications;

1. The coating is to be applied to the surface of the roofing foam in a minimum of three uniform applications. The base coats and topcoats shall be of contrasting colors to assure uniformity of coverage. Using a “swinging arm” technique while walking a line backwards with the spray gun does not provide consistent coating thickness and is **not recommended**. This method has the spray gun at a different angle, application rate, and pressure through the entire arc of the spray application. Holding the spray gun in a fixed position (90° perpendicular to the deck) with proper overlap, and walking back and forth will provide consistent results, with the spray gun angle, application rate, and pressure to provide even mil thickness. Subsequent coats should be applied with a crosshatch direction to the previous coating application.

2. A **base coat** of the Specified Coating shall be applied at a minimum rate of 1.0 gallon per 100 sq. ft. to a minimum finished dry film thickness of 7-10 TDM. All detail caulking and finish work shall be performed prior to the application of the next coating application. There shall not be any voids, pinholes, or exposed foam visible after completion of the base coat application. Additional coating will be required to meet the above minimum requirements.
3. The **mid-coat** of the Specified Coating shall be applied at a minimum rate of 1.5 gallons per 100 sq. ft. in a contrasting color to that of the base coat material. If a **Double Granule** specification is specific the first application of roofing granules shall be applied into the mid-coat application.
4. The **top-coat** application shall be applied at 1.5 -2.0 gallons per 100 sq. ft. in a contracting color to that of the mid-coat application and a total of 40 to 50 lbs. per 100 square feet of RTC WHITE **Energy Star® Qualified Product** granules or 3M C-93 gray granules shall be broadcast into the final coating application while it is still wet. A tan or buff colored top coating may spray applied and 3M C-68 Buff granules may be embedded into the coating where a natural colored roof is preferred. **Complete coverage with granules to the point of “refusal” shall be required.** Areas without granule cover (bare spots or “shiners”) shall be re-coated and granulated to provide complete coverage.
5. Coating thickness of the base coats, mid-coat, and top coat shall be verified by the application contractor each day prior to applying the next coat. Acceptable minimum thickness shall be indicated on the roof plan on the Daily Report Form. Special attention must be taken to drain areas, roof edges, equipment installation areas, scarified foam areas to ensure that they meet minimum thickness requirements. Additional coating material shall be applied to meet the minimum thickness requirements as specified. It is recommended that several additional hand rolled coats of coating be applied at the foam stop edge for additional protection from abrasion and mechanical damage. The **specified thickness** of coating shall be **verified** using an optical comparator at a minimum of the following areas;
 - a. **Roofing Field**
 - b. **Parapet Walls**
 - c. **Curbs**
 - d. **Roof Edge**
 - e. **HVAC Ducts**

Areas that are found to have less than the specified thickness shall require additional coating.

C. Coating Yield;

Dry Film Calculations;

Solids Content by Volume X 16 = Theoretical

Theoretical Mills X .85 (15% loss) = Actual

Example;

60% solids X 16 X .85 = 8.16 Actual Dry Mills Per Gallon

Poor foam texture may require additional coating to achieve the specified coating thickness. Rough orange peel texture or verge of tree bark may require 50% additional coating.

Coating thickness is a measure of desired durability, resistance to foot traffic, and mechanical abuse. More coating thickness adds to the longevity of the roof system and its sustainable qualities and are proportionate to the manufacturer's length of warranty.

1. Two coat "single granule" application thickness, applied at **3.0** gallons per 100 sq. ft. should yield; **22-25 dry mils.**
Warranty Eligibility - Permax[®] 5 + 5 Year Material Warranty
Warranty Eligibility - Permax[®] 5 Year "Perma-Plus" Systems Warranty
2. Three coat "single granule" application thickness, applied at **4.0** gallons per 100 sq. ft. should yield; **30-32 dry mils.**
Warranty Eligibility - Permax[®] 10 Year Material Warranty
Warranty Eligibility - Permax[®] 10 Year "Perma-Plus" Systems Warranty
3. Three coat "single granule" application thickness, applied at **4.5** gallons per 100 sq. ft. should yield; **35-40 dry mils.**
Warranty Eligibility - Permax[®] 10 + 10 Year Material Warranty
Warranty Eligibility - Permax[®] 15 Year "Perma-Plus" Systems Warranty
4. Three coat "double granule" application thickness, applied at **5.5** gallons per 100 sq. ft. should yield; **40-45 dry mils.**
Warranty Eligibility - Permax[®] 15 "Perma-Plus" Systems Warranty
Warranty Eligibility - Permax[®] 20 Year "Perma-Plus" Systems Warranty

D. Clean Up;

1. **Remove all loose granules after the roof coating has cured to prevent them from washing into gutters or onto the ground.**

E. Precautions;

1. Acrylic Coatings;

- a. Acrylic coatings are sensitive to temperature, moisture, and application thickness. Exceeding the application recommendations or installation parameters can result in mud cracking, blisters, or uncured coating. The water must evaporate from the coating for it to cure. High humidity can cause slowing of the curing process and potential for wash-offs.
- b. Air temperature must be a minimum of 55°F and rising for acrylic coatings to cure. Darker colors will skin and generate slight amounts of heat in cold weather to help cure. Do not store coating outdoors when temperatures are low and consideration for adding heat during overnight storage will help. Application rates should be limited to ¾ gallon to 1.0 gallons in cooler conditions. It may be a requirement to implement Permax® Fast Set coatings (see dry chart at end of this section) if weather conditions do not improve, or Permax® Instant Set Technology if wash-offs or constant rain occur. Top coat applications where granules are added can be applied at 1.5 gallons per 100 sq. ft. as the granules do help absorb and dissipate the moisture in the coating.
- c. Excessive high temperatures are also detrimental to proper coating curing, use lighter colors. Excessive coating thickness application can result in top surface skinning and blistering in the body or mud cracking of the coating. Always be prepared to backroll or evenly distribute the coating around pipes, roof drains, curbs, skylights, and parapet walls when applied in excess thickness.

2. Urethane Coatings;

- a. Moisture cured urethane coatings (with or without activator) must be applied in the basic same temperature ranges as the acrylic coatings group.

Heat may be added to the containers to help achieve spray viscosity, **do not add solvent or thin**. It may be a requirement to back-roll the coating to achieve a consistent application. Larger hose diameter ($\frac{3}{4}$ ") is generally required.

- b. Urethane coatings should not be left in the application hoses or equipment overnight.

3. **Silicone Coating Systems;**

- a. Silicone coating systems must be handled similar to urethane coatings in that excessively low temperatures results in higher non-sprayable viscosities. Larger hose diameter ($\frac{3}{4}$ ") is generally required.
- b. Silicone coatings should not be left in the application hoses or equipment overnight.
- c. Caution should be taken on projects where silicone coating is applied near polyurethane foam tie-in lines. Silicone overspray may negate adhesion of additional spray foam insulation when tying into existing foamed areas.

F. **Contractor Inspection;**

- 1. Upon completion of any job and review of the daily reports by the contractor, this review of base coat and mid-coat slit samples will determine the final coating application thickness required to meet the specifications or meet RTC Warranty requirements. Upon review and installation of the top coat application the contractor should verify the finished coating thickness by cutting slit samples and verifying that they have met the project requirements prior to requesting a manufacturers inspection.

G. **Warranty Request;**

- 1. To expedite a Manufacturers Warranty the appropriate Warranty request form (WR105 or WR106) must be completed. In some cases a copy of the specifications will be required. A roof sketch or copies of project drawings showing the building footprint are required. Multiple building projects must be identified on page three with the square footage for each building.

2. Home Owner Association (HOA) Projects must complete the HOA Supplemental Project Forms. These projects must have the HOA site plan included.

PERMAX

STANDARD COLORS



OFF WHITE



LIGHT GRAY

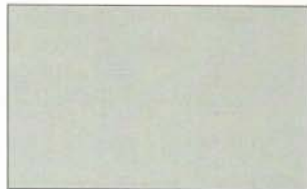

GRAY



DARK GRAY

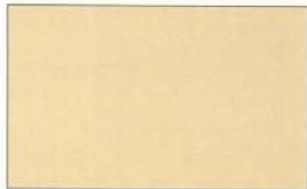

TAN



ARIZONA TAN



BUFF



TERRA COTTA

Resin Technology Division



DRY CHART

PERMAX-108-RH White (Wet 24 mils)
Time to Skin Development (hrs.)

Temp./RH	40%	60%	70%	80%	90%
40°F	-	-	5.5	11.0	-
60°F	2.5	2.5	-	-	10.0
80°F	1.0	2.75	-	3.5	6.5

PERMAX-108-FS White (Wet 24 mils)
Time to Skin Development (hrs.)

Temp./RH	40%	60%	70%	80%	90%
40°F	-	-	1.25	2.25	-
60°F	1.0	1.0	-	1.25	1.25
80°F	.75	.75	-	.75	.75

NOTE: All tests based on 12 hour scale.

2270 Castle Harbor Place • Ontario, CA 91761
(800) 729-0795 • (909) 947-7224 • FAX (909) 923-9617 • www.resintechnology.com

Corporate Headquarters
2911 Slauson Avenue • Huntington Park, CA 90255

PERMAX[®] POLYURETHANE ROOFING INSTALLATION MANUAL

SECTION 18

COATING BLISTERS, IDENTIFICATION and REPAIR.

A. Coating Blister Identification; Acrylic coatings, Urethane coatings, and Silicone coatings have specific application requirements which if not followed can produce defects in the finished coating system.

1. Acrylic Coatings; Generally it is found that any application above a 1 ½ gallon per 100 sq. ft. could produce a coating blister depending on ambient air temperature, humidity, and wind conditions. Application rates up to 2.0 gallons per 100 sq. ft. may be applied if that coat is to receive granule surfacing and all other conditions are met.

When the specification approaches 30 dry mils it is recommended that the coating be applied in three separate applications to avoid blistering or a wash-off potential uncured materials.

The following conditions or application pitfalls should be avoided as they can easily cause blistering or other defects;

- Wet or damp substrate
- Ambient air temperatures of 55°F and dropping
- Freezing night temperatures
- Excessively dark colors on warm days

The following application practices will reduce blistering problems;

- Substrate must be dry
- Limit application rate with cool temperatures to 1.0 gallon per 100 sq. ft. and terminate coating application with enough daylight left to provide a skin on the coating. Use dark colors to absorb heat and accelerate the cure time. Fast set coatings may be needed.

- Limit the application rate in excessively high temperatures to 1.0 gallon per 100 sq. ft. and use off-white and/or other light colors.
 - Back-roll all coating which is applied over ground foam.
 - Always roll-out excess coating applied to pipes, flashings, and parapet walls.
2. Polyurethane Coating Systems vary from moisture cure (slow cure) to 100% solids snap cure materials when sprayed with plural component equipment. Similar defects to the acrylic coatings may occur and can be solved with some of the same applications techniques. Trapped solvent can result in blistering or cellularity of the membrane. Most applications require daily solvent flush.
 3. Silicone Coating Systems may not experience all of the above noted problems as with the acrylic and polyurethane coating systems, but excessive application thickness per coat must be avoided. These systems tend to be more costly per gallon and solvent flushing must be performed daily.
- B. Coating Blister and Mechanical Damage Repair; When repairs to any of the above coating systems is performed it is a requirement to trim the blister or damaged coating back to soundly bonded coating.

If elastomeric caulking is used to fill or level the void, it must be top coated with the specified coating materials. If multiple coats of coating are used for this repair care should be used to control thickness. Granules may be used to add thickness to repairs.

PERMAX[®]
POLYURETHANE ROOFING
INSTALLATION MANUAL

SECTION 19

APPLICATION OF GRANULE WALKWAY SURFACING

A. Walkways;

1. Areas approximately 4 feet wide, or as defined on the roof plans, around equipment installations, designated walkways, roof-top landings (may be wider than 4 feet), hatchways and at the bottom of equipment wells shall receive the following treatment. Mask or lay spray edges (boards) to provide straight walkway lines when applying coating.
2. After the top-coat material has completely cured and all loose granules have been removed, apply an additional minimum 2.0 gallons per 100 square feet of protective top coating and embed 40 to 50 lbs. per 100 square feet of ceramic granules into the wet coating. Walkway granules shall be a contrasting color (White, Gray or Tan) to the finished color of the roof field.
3. **Remove all loose walkway granules after the roof coating has cured to prevent them from washing into gutters or onto the ground.**

PERMAX[®]
POLYURETHANE ROOFING
INSTALLATION MANUAL

SECTION 20

MAINTENANCE RECOATING

PART 1 GENERAL REQUIREMENTS

- A. Approved substrates include existing granulated SPRS, which have been inspected and are in generally good condition as follows:
1. The roof should be in good general condition, with the SPRS materials properly adhered to each pass application and to the substrate. The coating materials should still be somewhat elastic, and still protect the polyurethane from UV exposure.
 2. The roof should have good water drainage, little mechanical damage with few (if any) repairs made with conventional materials.
 3. A test core shall be taken through the SPRS roof (the core cut void shall be properly repaired, returning the site to a watertight condition).
 4. The core materials shall be examined for, adhesion to the substrate, composite adhesion (all SPRS material layers) with particular attention paid to the adhesion of the coating to the insulation. Brittle coating or coating poorly adhered to the insulation surface shall be brought to the attention of Resin Technology Company (RTC) prior to recoating the roof. These roofs may not be recoat candidates.
 5. If the existing roof coating system has deteriorated and allowed the insulation to be exposed to ultraviolet radiation (sun light), RTC shall be consulted prior to recoating the roof. These roofs may not be recoat candidates.
 6. Some urethane elastomeric coating products can undergo a process known as “chemical reversion”.

When this phenomenon has occurred the coating will be “sticky” to the touch particularly when warmed by the sunlight. This condition is very difficult to resolve and shall be referred to RTC. These roofs may not be recoat candidates.

PART 2 MATERIALS

- A. Acrylic and Urethane Coated Polyurethane Foam Roofs: Primer shall be a water-based acrylic primer designed to enhance adhesion over previously coated polyurethane or acrylic coated roofs. The product shall be Acryprime – Recoat Primer as manufactured by Resin Technology Company, Ontario, CA.
- B. It is recommended that existing acrylic coated roofs be recoated with acrylic coating. Permax-108, Permax-120, and Permax-115 may be specified for acrylic recoats. Contact your RTC Permax salesman for help in selecting the appropriate coating system.
- C. Existing polyurethane roofs may be recoated with a Polyurethane coating systems such as Permax-500/600. It may also be possible to re-coat a polyurethane coated roof using an acrylic coating system such as Permax-115. It may also be acceptable to re-coat using a silicone coating such as Permax-2000.
- D. Existing silicone coated roofs when properly power washed do not require a primer. Existing silicone coated roofs can only be recoated with Permax-2000 silicone coating material.
- E. **The thickness, total dry mil (TDM) of the recoat coating applied over the existing coating system shall be verified using an optical comparator, shall be 20 to 24 TDM.**

PART 3 EXECUTION

3.01 Preparation

- A. Inspect roof surface and establish the presence of any blisters in the existing insulation or saturated or delaminated areas.
- B. Identify all areas where temporary repairs have been made around new penetrations or on parapet walls.

These areas shall be permanently repaired by installing new sprayed polyurethane foam.

- C. Surface Condition: Identify and repair all leaks realizing that the following areas are the most critical:
 - 1. Internal roof drains and scuppers.
 - 2. Edge details, parapet walls, and corner flashings.
 - 3. Expansion joints and skylights.
 - 4. HVAC Units, ducts, mechanical equipment, and supports.
 - 5. Other roof penetrations such as soil pipes, ventilators and curbs.
- D. Prime all areas to receive new polyurethane insulation. Flash all new penetrations with foam insulation. Spot repairs must be ground to match surrounding grade and sealed with Permax-coating (1 gallon per 100 square feet).
- E. Remove all foam blisters to sound material. Cut-out blisters shall be cut at a 45° angle and a minimum of 4-inches into sound foam. The bottom of the blistered area shall be scarified prior to priming. Air blast clean and re-foam. Grind all repairs to match the surrounding grade. Permax-Coating shall be applied to all newly applied foam areas to match the existing specification prior to installing the re-coat specification. **All repairs shall match the surrounding grade without excess thickness and bumps.**
- F. Delaminated and saturated insulation shall be removed and the area primed, and re-sprayed. Repair all bird pecks and other mechanical damage by cutting away the damaged material or temporary repair materials (wet patch or mastic) and filing the void with a single component urethane caulking material. Larger repair areas shall be re-foamed. Smooth the repaired area to conform to the surrounding roof grade.
- G. Remove all loose or delaminated coating material. The surface shall be free from solvent, grease, dust, sediment, dirt and sticky mastic.
- H. Remove all loose granules, dirt, and debris from roof. Power wash all roof and parapet wall surfaces. Some areas may require power washing with a diluted solution of TSP followed

by a thorough power rinse to remove dirt and contaminants from low area or excessive dirty areas. It is essential that all dirt be removed to ensure a clean surface for the primer to bond to. Rinse water shall be diverted to proper drains. Allow the roof surface to dry completely before priming.

- I. Repair or replace all A/C condensate conduit lines and run to drains or off the roof.
- J. Inspect all roof termination points, parapet walls, foam stops and counterflashings. It is a requirement to reseal all roof edges if there currently exists a delaminating of foam or coating prior to installed the re-coat specification.

3.02 Coating Application

- A. Spray apply 1/3 to 1/2 gallon per 100 square feet of Acryprime-Recoat primer to the entire roof surface to be recoated. Roll out excessive primer from low areas. Allow the primer to cure completely.
- B. The roof perimeter shall be coated in a picture frame fashion and back rolled at areas where the insulation has been scarified with a application of coating applied at **1.5 X** the specified thickness.
- C. The coating is to be applied to the properly prepared surface of the roof in a minimum of two uniform passes. The base coat and topcoat shall be of contrasting colors to assure uniformity of coverage. The specified thickness of coating shall be applied to the roof as determined by an optical comparator.
- D. **Base Coat;** Over the cured primer a base coat of Permax-Coating shall be applied at a minimum rate of 1.5 gallons per 100 sq. ft. and shall be backrolled.
- E. Inspect the cured base coat application and repair any and all defects such as, thin coating, blistered coating (excessive thickness), mechanical damage, roofs edges, pinholes with elastomeric caulking or hand rolled Permax-115.
- F. **Top Coat;** Over the cured base coat material apply the topcoat application of White Permax-Coating at a minimum rate of 1.5 gallons per 100 sq. ft.
- G. **WHITE GRANULE FINISH OPTION:** If specified, to roof areas apply the white Permax top coat at a minimum rate of

1.5 – 1.75 gallons per 100 square feet. Broadcast a total of 40-50 lbs. per 100 square feet of **RTC White** roofing granules into the final coat while it is still wet. **Complete coverage with granules to the point of “refusal” shall be required.** Areas without granule coverage (bare spots or “shiners”) shall be re-coated and granulated to provide complete coverage.

- H. **Remove all loose granules after the roof coating has cured to prevent them from washing into gutters or onto the ground.**

PERMAX[®]
POLYURETHANE ROOFING
INSTALLATION MANUAL

SECTION 21

CONDUIT and PIPING

A. Small Conduit;

1. All small conduit and gas lines, 1 1/2 inch and under must be raised off the roof. After the roof has been foamed, the conduit shall be reset on new redwood 2" x 4" set on top of the foam. The wood blocks shall be caulked to strips of Yellow Spaghetti walk pads, which are caulked to the granulated top coated foam roof. The old conduit supports shall not be reused. Replace any broken EMT connectors.

B. Large Conduit;

1. Large conduit and piping, 1 3/4 inch and larger, shall have new redwood blocks with 24 ga. Galvanized sheet metal boxes fabricated with minimum 6-inch flange on roof with all joints soldered. These boxes with wood blocks shall be nailed over the existing roof membrane, primed, and foamed into place. Piping shall be set onto the blocks with covers and conduit attached with clamps. **Note: Conduit and piping which move during use such that the roof system may be damaged shall be set upon appropriate roller saddle supports or other vibration isolating devices.**
2. When re-blocking existing conduit or piping use minimum 4" x 4" redwood blocks, keeping the lines as high as possible above the foam roof. Use 12-inch minimum length blocks set on spaghetti walk pad material. If more than one conduit or piping line will be set on the same blocking, increase blocking size so that 6-inch of blocking shall extend at each side of conduit and piping. Space blocking at every joint and mid-span (maximum of 5-feet between blocks). Align all blocking, conduit and piping lines prior to final anchorage. All lines that are not straight and true prior to commencement of the roof work shall be adjusted prior to final anchorage to the new roofing at the discretion and approval of the Owner/Inspector. Secure small conduit lines and piping with galvanized clamps using galvanized fasteners. Secure large conduit and piping with Unistrut

base steel and associated fasteners with brackets secured to wood blocks, or fabricate minimum 2 x 2-inch square steel tubing, with mounting plates mechanically attached to deck, and welded tops and fasten Unistrut to these fabricated stands. Do not foam Unistrut into the roof.

SECTION 22

ROOFING DETAILS

- Detail 1 HVAC Equipment Platform
- Detail 2 Internal Roof Drain
- Detail 4 Parapet Wall No Metal
- Detail 5 Parapet Wall Foam Stop Metal
- Detail 6 Parapet Wall with Coping
- Detail 7 Thru-Wall Scupper
- Detail 9 Conduit and Pipe Support
- Detail 10 Skylight
- Detail 12 Building Expansion Joint
- Detail 16 Standard Perimeter Edge Metal Flashing Edge
- Detail 17 Perimeter Edge Metal Flashing Raised Edge
- Detail 18 Pipe Penetration
- Detail 21 Parapet Wall / Counterflashing
- Detail 33 Pre-Fab Metal A/C Curb w/Counterflashing

DETAIL 1, HVAC / EQUIPMENT PLATFORM

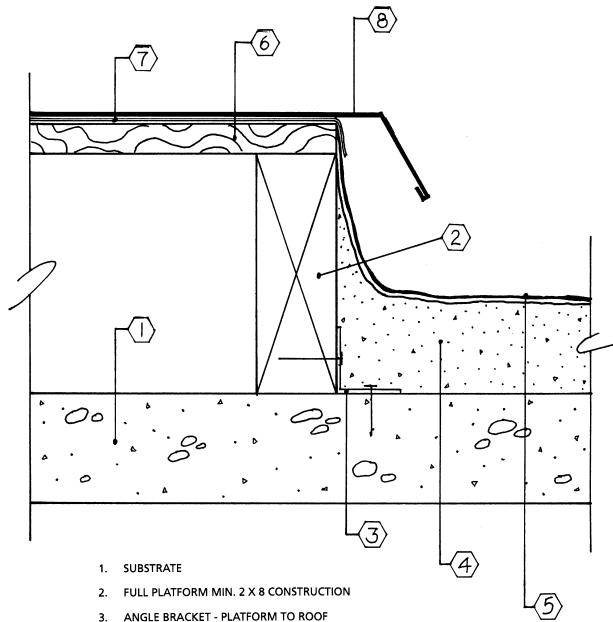

1. SUBSTRATE
2. FULL PLATFORM MIN. 2 X 8 CONSTRUCTION
3. ANGLE BRACKET - PLATFORM TO ROOF
4. SPRAYED POLYURETHANE INSULATION
5. ELASTOMERIC COATING SYSTEM (WITH GRANULE SURFACING)
6. MINIMUM 1/2 INCH PLYWOOD PLATFORM TOP
7. HENRY RUFTAC OR SINGLE PLY MEMBRANE
8. 24 GA. GALVANIZED SEAMLESS OR STANDING SEAM PLATFORM COVER

DETAIL 4, PARAPET WALL / NO METAL

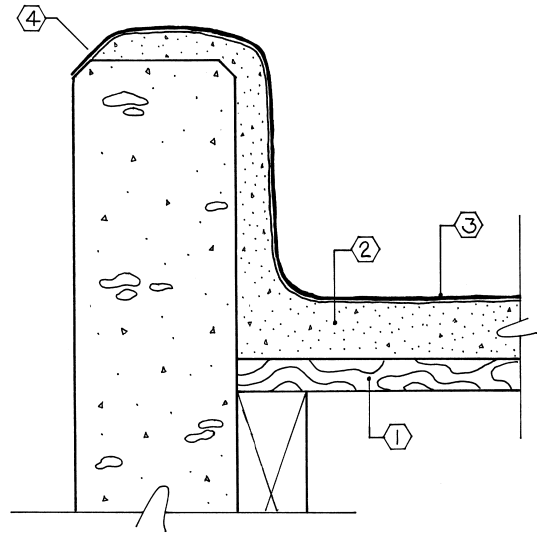

1. SUBSTRATE
2. SPRAYED POLYURETHANE INSULATION
3. ELASTOMERIC COATING SYSTEM (WITH GRANULE SURFACING)
4. POLYURETHANE INSULATION APPLIED TO TOP OF WALL AND GROUND SMOOTH AT 45 DEGREE ANGLE OR TO PARAPET WALL CHAMFER ANGLE.

DETAIL 2, INTERNAL ROOF DRAIN

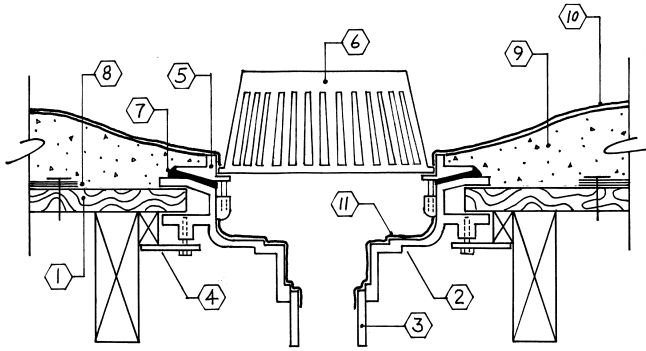

- | | |
|--|------------------|
| 1. SUBSTRATE | 4. DECK CLAMP |
| 2. DRAIN BOWL | 5. CLAMPING RING |
| 3. DRAIN PIPE | 6. STRAINER |
| 7. ELASTOMERIC SEALANT | |
| 8. BUILT-UP ROOFING REMOVED MINIMUM 12 INCHES FROM DRAIN BOWL FLANGE. EDGE OF BUR TO BE MECHANICALLY ATTACHED TO SUBSTRATE | |
| 9. SPRAYED POLYURETHANE INSULATION | |
| 10. ELASTOMERIC COATING SYSTEM WITH GRANULE SURFACING, DOUBLE COATING THICKNESS AROUND DRAIN AREA | |
| 11. RUN ELASTOMERIC COATING OVER CLAMPING RING AND INTO DRAIN BOWL | |

DETAIL 5, PARAPET WALL / PERIMETER EDGE METAL FLASHING

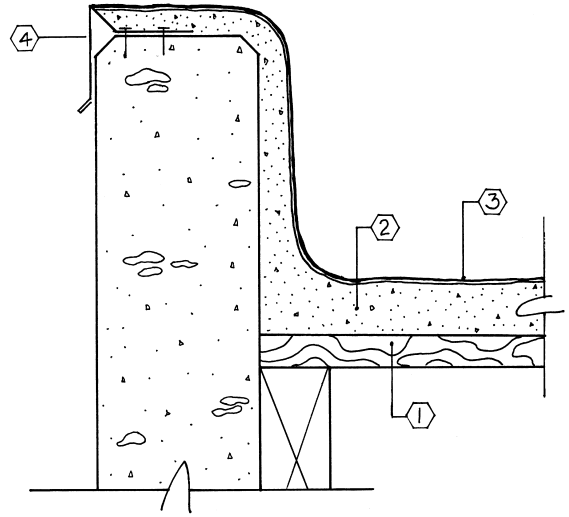

- | |
|--|
| 1. SUBSTRATE |
| 2. SPRAYED POLYURETHANE INSULATION |
| 3. ELASTOMERIC COATING SYSTEM (WITH GRANULE SURFACING) |
| 4. 24 GA. GALVANIZED EDGE METAL MECHANICALLY ATTACHED WITH CONCRETE SCREWS OR EXPANDING FASTENERS MINIMUM 9 INCH ON CENTER |

DETAIL 6, PARAPET WALL / WITH COPING

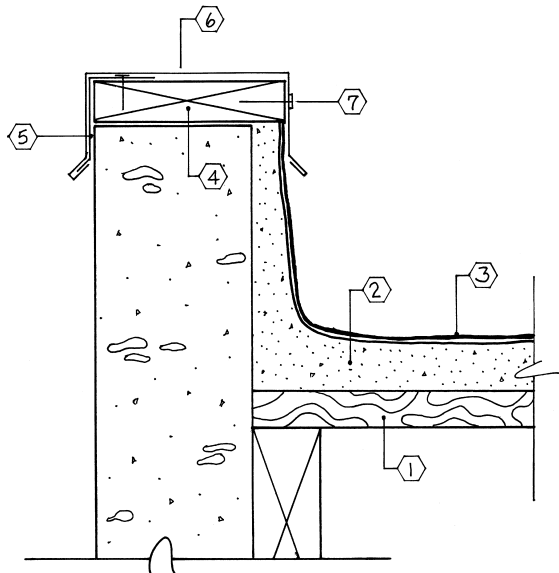

- | |
|---|
| 1. SUBSTRATE |
| 2. SPRAYED POLYURETHANE INSULATION |
| 3. ELASTOMERIC COATING SYSTEM (WITH GRANULE SURFACING) |
| 4. TREATED WOOD NAILER MECHANICALLY ATTACHED TO TOP OF PARAPET |
| 5. 22 GA. GALVANIZED CLEAT MECHANICALLY ATTACHED TO WOOD NAILER |
| 6. 24 GA. GALVANIZED STANDING SEAM COPING |
| 7. FASTENED WITH NEOPRENE PAD GASKET |

DETAIL 9, CONDUIT AND PIPE SUPPORT

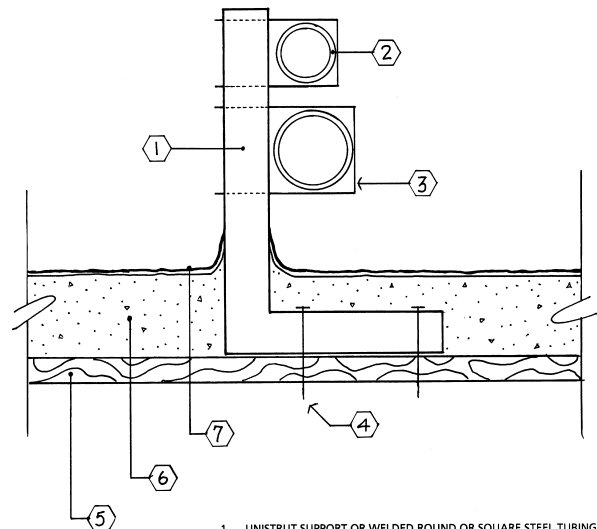

- | |
|--|
| 1. UNISTRUT SUPPORT OR WELDED ROUND OR SQUARE STEEL TUBING |
| 2. CONDUIT OR PIPING |
| 3. U-BOLT OR UNISTRUT FASTENER |
| 4. BRACKET FASTENED TO DECK MAY REQUIRE UNDERSIDE BLOCKING |
| 5. SUBSTRATE |
| 6. SPRAYED POLYURETHANE INSULATION |
| 7. ELASTOMERIC COATING SYSTEM (WITH GRANULE SURFACING) |

DETAIL 7, THRU-WALL SCUPPER

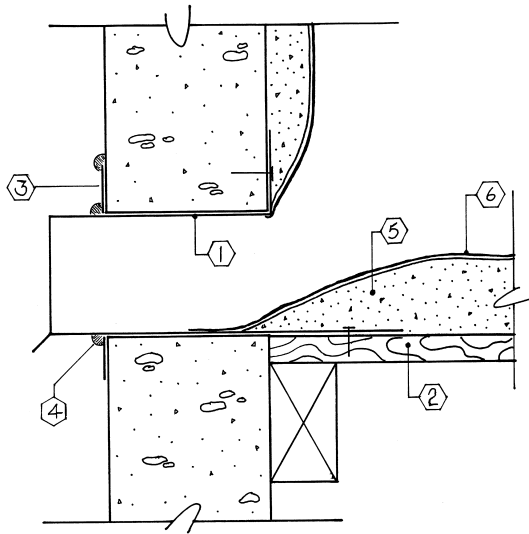

1. 24 GA. GALVANIZED SCUPPER ALL JOINTS SOLDERED
 2. SUBSTRATE
 3. EXTERIOR COVER PLATE
 4. ELASTOMERIC CAULKING
 5. SPRAYED POLYURETHANE INSULATION
 6. ELASTOMERIC COATING SYSTEM (WITH GRANULE SURFACING)
- NOTE: INSIDE OPENING NOT TO SCALE

DETAIL 10, SKYLIGHT

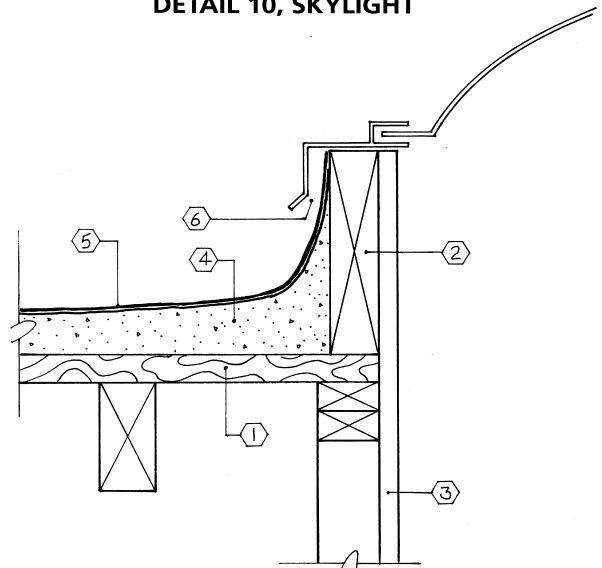

1. SUBSTRATE
 2. SKYLIGHT CURB 2" X 8" OR MINIMUM 6 INCHES ABOVE FINISHED ROOF
 3. INTERIOR DRYWALL
 4. SPRAYED POLYURETHANE INSULATION
 5. ELASTOMERIC COATING SYSTEM (WITH GRANULE SURFACING)
 6. INSTALL 2" COUNTERFLASHING IF POLYURETHANE AND PROTECTIVE COATING CANNOT BE APPLIED UNDER SKYLIGHT FRAME
- NOTE: CURB MAY BE METAL (OPTIONAL, VENTS)

DETAIL 12, BUILDING EXPANSION JOINT

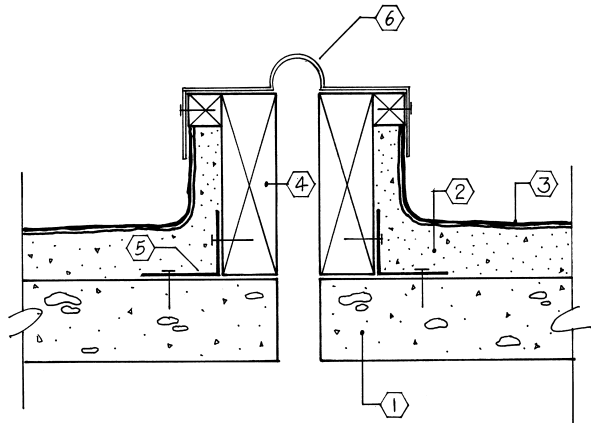

1. SUBSTRATE
2. SPRAYED POLYURETHANE INSULATION
3. ELASTOMERIC COATING SYSTEM (WITH GRANULE SURFACING)
4. MINIMUM 2" X 10" CURB
5. ANGLE BRACKET SECURES CURB TO SUBSTRATE WITH MECHANICAL FASTENERS
6. RUBBER EXPANSION JOINT COVER EXPAND-O-FLASH (MANVILLE OR EQUAL)

DETAIL 17, PERIMETER EDGE METAL FLASHING RAISED EDGE

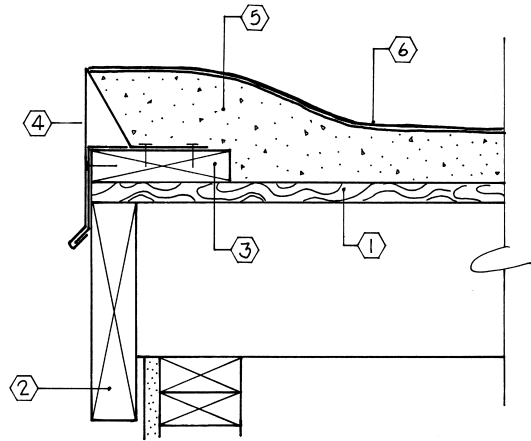

1. SUBSTRATE
2. FACIA
3. RAISED EDGE NAILER (DESIGN HEIGHT VARIES)
4. 24 GA. GALVANIZED EDGE METAL ATTACHED 4 INCH ON CENTER
5. SPRAYED POLYURETHANE INSULATION
6. ELASTOMERIC COATING SYSTEM (WITH GRANULE SURFACING)

DETAIL 16, STANDARD PERIMETER EDGE METAL FLASHING

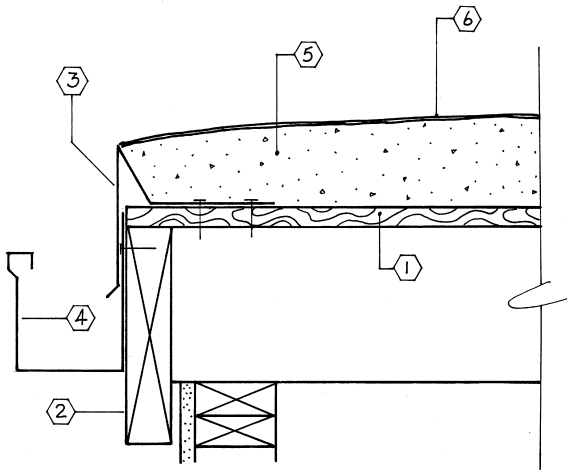

1. SUBSTRATE
2. FACIA
3. 24 GA. GALVANIZED EDGE METAL ATTACHED 4 INCH ON CENTER
4. MINIMUM 22 GA. GALVANIZED GUTTER GRADED (OPTIONAL)
5. SPRAYED POLYURETHANE INSULATION
6. ELASTOMERIC COATING SYSTEM (WITH GRANULE SURFACING)

DETAIL 18, PIPE PENETRATION

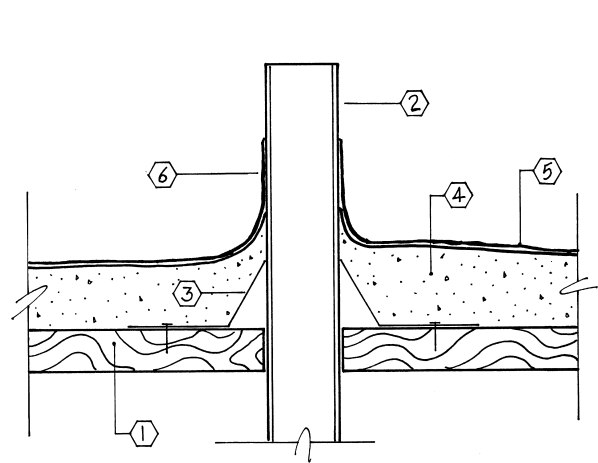

1. SUBSTRATE
2. SOIL PIPES
3. 24 GA. GALVANIZED STANDARD G.I. FLASHING
4. SPRAYED POLYURETHANE INSULATION
5. ELASTOMERIC COATING SYSTEM (WITH GRANULE SURFACING)
6. PROTECTIVE COATING TO EXTEND A MINIMUM 2 INCHES BEYOND INSULATION TERMINATION

DETAIL 21, PARAPET WALL / COUNTERFLASHING

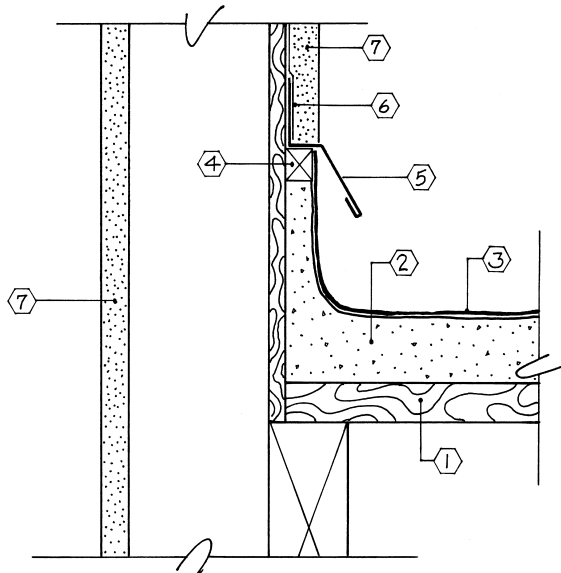

1. SUBSTRATE
2. SPRAYED POLYURETHANE INSULATION
3. ELASTOMERIC COATING SYSTEM (WITH GRANULE SURFACING)
4. WOOD FOAM SCREED MINIMUM 8 INCHES ABOVE ROOF LINE
5. GALVANIZED STUCCO 'Z' FLASHING
6. UNDERLAYMENT
7. STUCCO

**DETAIL 33, PRE-FAB METAL A/C CURB
EXISTING BUR**

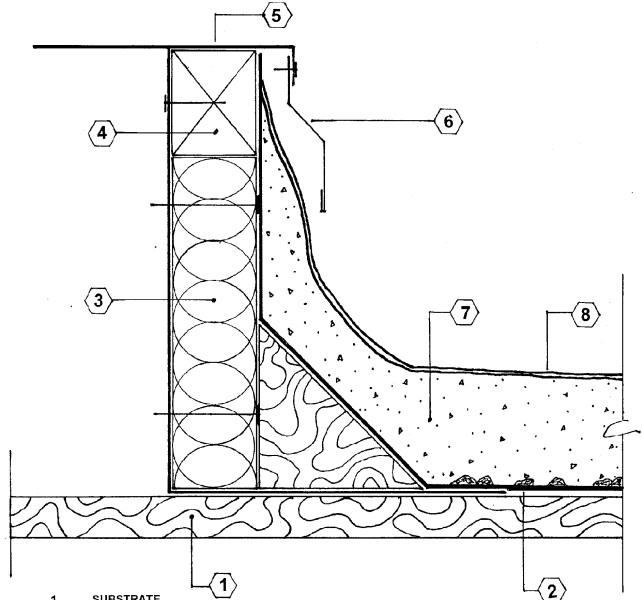

1. SUBSTRATE
2. BUILT-UP ROOF GRAVEL SURFACED
3. RIGID INSULATION
4. NAILER
5. HEAVY GAUGE GALVANIZED PRE-FAB METAL HVAC CURB
6. 24 GA. GALVANIZED 'Z' COUNTERFLASHING MECH. ATTACHED TO EXISTING CURB

SECTION 23

ROOFING FORMS

- A. Roof Weight Calculation Work Sheet
- B. Project Materials Inventory Form
- C. Contractors Daily Report, page 1 and 2
- D. Contractors Final Inspection Form, page 1 and 2
- E. RTC Warranty Request Form WR-105
- F. RTC Warranty Request Form WR-106
- G. Signature Page

SPRAYED POLYURETHANE ROOFING SYSTEMS (SPRS) RE-ROOF WEIGHT WORKSHEET

PROJECT _____ DATE _____

PROJECT SPECIFICATIONS _____

FOAM THICKNESS _____

FOAM DENSITY _____ COATING THICKNESS _____ GRANULES: _____ SINGLE _____ DOUBLE

EXISTING BUR TO BE RECOVERED
(WEIGHT IS PER 100 SQ. FT. OF ROOF AREA, FELTS INCLUDE 25# ASPHALT MOPPING)

Thickness,
number of
plys, #'s per
square

INSULATION	BASE PLY #25 (NO ASPHALT)	PLY SHEETS (36# PER PLY/ASPHALT)	CAPSHEET (97# INCL. ASPHALT)	FLOOD COAT & ROCK	TOTAL PER SQUARE

POLYURETHANE INSULATION 2.5# DENSITY
(WEIGHT IS PER 100 SQ. FT. OF ROOF AREA)

1"	1 ½"	2"	2 ½"	3"	3 ½"	4"	SPECIFIED
20.8 LBS.	31.2 LBS.	41.6 LBS.	52.0 LBS.	62.5 LBS.	72.8 LBS.	83.3 LBS.	

POLYURETHANE INSULATION 3.0# DENSITY
(WEIGHT IS PER 100 SQ. FT. OF ROOF AREA)

1"	1 ½"	2"	2 ½"	3"	3 ½"	4"	SPECIFIED
25.0 LBS.	37.5 LBS.	50.0 LBS.	62.5 LBS.	75.0 LBS.	87.5 LBS.	100.0 LBS.	

ELASTOMERIC COATING
68% SOLIDS BY WEIGHT 11.2 LBS/GAL
(WEIGHT IS PER 100 SQ. FT. OF ROOF AREA)

1.0 GPS	1.5 GPS	2.0 GPS	2.5 GPS	3.0 GPS	3.5 GPS	4.0 GPS	4.5 GPS	5.0 GPS	SPECIFIED
7.6 LBS.	11.4 LBS.	15.2 LBS.	19.0 LBS.	22.8 LBS.	26.6 LBS.	30.4 LBS.	34.2 LBS.	38.0 LBS.	

GRANULAR SURFACING
3M SIZE #11 ROOFING GRANULE
(WEIGHT IS PER 100 SQ. FT. OF ROOF AREA)

		SPECIFIED
SINGLE GRANULES	45 LBS.	
DOUBLE GRANULES	80 LBS.	

TOTAL WEIGHT OF NEW ROOFING

PROJECT MATERIALS INVENTORY FORM

OWNER _____ **DATE** _____

PROJECT _____ **ROOF SIZE** _____ **SQ.FT.**

ADDRESS _____ **LN. FT. EDGE** _____

CITY/STATE _____

CONTRACTOR _____

SPECIFICATION RATES: _____ **PRIMER** _____ **FOAM DENSITY & THICKNESS**

COATING TYPE & APPLICATION RATE _____ **DRY MILS** _____

CONTRACTORS TOTAL ESTIMATED MATERIAL AMOUNTS TO COMPLETE PROJECT

MATERIAL DESCRIPTION	MANUFACTURER	PRODUCT	AMOUNT
PRIMER			
POLYURETHANE FOAM			
PROTECTIVE COATING			
GRANULES			
METAL AND FLASHINGS			

MATERIALS DELIVERED TO JOBSITE FOR PROJECT BY VENDOR , CONTRACTOR, OR SUB-CONTRACTOR

MATERIAL DESCRIPTION	MANUFACTURER	PRODUCT	AMOUNT

DAILY REPORT

JOB NUMBER _____

REPORT # _____

(USE ADDITIONAL SHEETS FOR MULTIPLE CREWS OR IF WORK IS PERFORMED ON MULTIPLE ROOFS)

DATE _____

OWNER _____ CONTRACTOR _____

PROJECT _____ BUILDING I.D. _____

ADDRESS _____ CREW/FOREMAN _____

CITY/STATE _____ CREW SIZE _____ START TIME _____ AM / PM

 WEATHER ACCEPTABLE TO WORK WEATHER DAY – NO WORK CREW SENT HOME _____ AM / PM

AM WEATHER CONDITION; TEMP. _____ °F HUMIDITY _____ % WIND _____ MPH WIND DIRECTION; N S E W

NOON WEATHER COND; TEMP. _____ °F HUMIDITY _____ % WIND _____ MPH WIND DIRECTION; N S E W

PM WEATHER CONDITION; TEMP. _____ °F HUMIDITY _____ % WIND _____ MPH WIND DIRECTION; N S E W

TOTAL RF. SQS. PREP'D _____ SQS. TEAR-OFF _____ SQS. VAC'D _____ SQS. POWER WASHED _____

SQS. PRIMED _____ LN. FT. METAL INSTLD _____ SQS. FOAMED _____ SQS. BASE COATED _____

SQS. MID-COATED _____ SQS. TOP COAT/GRANULES _____ LBS. PER SQ. _____ SQS. LOCKCOAT _____

SQS. OTHER PREP. COMPLETED/DESCRIPTION _____

PRIMER:**MATERIALS INSTALLED**

APPLICATOR _____ PRIMER _____ MFGR _____

BATCH # _____ GALLONS USED _____ COLOR _____ APPLICATION RATE _____ GPS

FOAM:

APPLICATOR _____ FOAM (INCLD. DENSITY) _____ MFGR _____

BATCH # _____ LBS. SPRAYED _____ THICKNESS _____ # PASSES _____

TRUCK # _____ PROPORTIONER _____ GUN _____ TIP/MOD. _____

EQUIP. TEMP. SETTINGS; _____ °F 'A' MAIN _____ °F 'B' MAIN _____ °F HOSE HOSE LENGTH _____ FT.

SPRAY PRESSURE (FLUID) _____ PSI ESTIMATED GUN OUTPUT _____ LBS/MIN. SURFACE; _____ % SMOOTH

_____ % ORANGE PEEL _____ % ROUGH ORANGE PEEL _____ % VERGE OF POPCORN OTHER SURFACE

COMMENTS/CORRECTIONS NEEDED _____

BASE COAT:

APPLICATOR _____ TYPE COATING _____ MFGR _____

BATCH # _____ APPLICATION RATE _____ GPS GALLONS USED _____ COLOR _____

TYPE PUMP _____ TIP SIZE _____ PRESSURE SETTING _____ PSI HOSE DIA. _____

BACK-ROLL AT EDGES; YES NO COATS ON EDGE _____ PINHOLES; YES NO BLISTERS; YES NO

WET MILS APPLIED _____ TDM DRY MILS ACHIEVED _____ TDM MEETS OR EXCEEDS SPECS. YES NO

COMMENTS/CORRECTIONS NEEDED _____

MID-COAT:

APPLICATOR _____ TYPE COATING _____ MFGR _____
BATCH # _____ APPLICATION RATE _____ GPS GALLONS USED _____ COLOR _____
TYPE PUMP _____ TIP SIZE _____ PRESSURE SETTING _____ PSI HOSE DIA. _____
BACK-ROLL AT EDGES; YES NO COATS ON EDGE _____ PINHOLES; YES NO BLISTERS; YES NO
WET MILS APPLIED _____ TDM DRY MILS ACHIEVED _____ TDM MEETS OR EXCEEDS SPECS. YES NO
COMMENTS/CORRECTIONS NEEDED _____

TOP COAT / LOCK COAT:

APPLICATOR _____ TYPE COATING _____ MFGR _____
BATCH # _____ APPLICATION RATE _____ GPS GALLONS USED _____ COLOR _____
TYPE PUMP _____ TIP SIZE _____ PRESSURE SETTING _____ PSI HOSE DIA. _____
BACK-ROLL AT EDGES; YES NO COATS ON EDGE _____ PINHOLES; YES NO BLISTERS; YES NO
WET MILS APPLIED _____ TDM DRY MILS ACHIEVED _____ TDM MEETS OR EXCEEDS SPECS. YES NO
COMMENTS/CORRECTIONS NEEDED _____

GRANULES:

APPLICATOR _____ TYPE GRAN. USED MFGR _____ SIZE _____ COLOR _____
SINGLE / DOUBLE APPLICATION RATE _____ LBS PER SQ. TYPE GRAN. EQUIP. _____
COMMENTS/CORRECTIONS NEEDED _____

ROOF PLAN:

NORTH ↑

SKETCH ROOF, SHOW AREAS WORK PERFORMED

DATE _____

CONTRACTOR FINAL INSPECTION FORM

JOB NO. _____

PROJECT _____ BUILDING NO. _____

ADDRESS _____

OWNER REP. PRESENT _____

PROJECT SPECIFICATIONS _____

FOAM THICKNESS _____ COATING THICKNESS _____ GRANULES: _____ SINGLE _____ DOUBLE

	<u>OK</u>	<u>DEFECT</u>	<u>SQ. FT.</u>	<u>RE-WORK REQUIRED</u>
ROOF LEAKS	<input type="checkbox"/>	<input type="checkbox"/>	_____	_____
FOAM THICKNESS	<input type="checkbox"/>	<input type="checkbox"/>	_____	_____
COATING THICKNESS FIELD	<input type="checkbox"/>	<input type="checkbox"/>	_____	_____
COATING THICKNESS F.S. EDGE	<input type="checkbox"/>	<input type="checkbox"/>	_____	_____
PIPES SEALED, TOPS OPEN	<input type="checkbox"/>	<input type="checkbox"/>	_____	_____
SKYLIGHTS	<input type="checkbox"/>	<input type="checkbox"/>	_____	_____
CURBS & PROJECTIONS SEALED	<input type="checkbox"/>	<input type="checkbox"/>	_____	_____
FOAM TEXTURE/PROFILE	<input type="checkbox"/>	<input type="checkbox"/>	_____	_____
MECHANICAL DAMAGE	<input type="checkbox"/>	<input type="checkbox"/>	_____	_____
FOAM BLISTERES	<input type="checkbox"/>	<input type="checkbox"/>	_____	_____
EXPOSED FOAM	<input type="checkbox"/>	<input type="checkbox"/>	_____	_____
COATING BLISTERS	<input type="checkbox"/>	<input type="checkbox"/>	_____	_____
COATING PINHOLES	<input type="checkbox"/>	<input type="checkbox"/>	_____	_____
PROPER SLOPE ACHIEVED	<input type="checkbox"/>	<input type="checkbox"/>	_____	_____
ADHESION FOAM TO SUBSTRATE	<input type="checkbox"/>	<input type="checkbox"/>	_____	_____
ADHESION FOAM TO FOAM	<input type="checkbox"/>	<input type="checkbox"/>	_____	_____
ADHESION COATING TO FOAM	<input type="checkbox"/>	<input type="checkbox"/>	_____	_____
ROOF DRAINS/SCUPPERS CLEAR	<input type="checkbox"/>	<input type="checkbox"/>	_____	_____
LEAF CATCHERS/SCREENS	<input type="checkbox"/>	<input type="checkbox"/>	_____	_____
GRANULE WALKWAYS	<input type="checkbox"/>	<input type="checkbox"/>	_____	_____
MASKING REMOVED	<input type="checkbox"/>	<input type="checkbox"/>	_____	_____
PARAPETS SEALED	<input type="checkbox"/>	<input type="checkbox"/>	_____	_____
TIE-IN OTHER ROOF SYSTEMS	<input type="checkbox"/>	<input type="checkbox"/>	_____	_____
COPING INSTALLED	<input type="checkbox"/>	<input type="checkbox"/>	_____	_____
COUNTERFLASHING INSTALLED	<input type="checkbox"/>	<input type="checkbox"/>	_____	_____
HVAC UNITS/CONDENSATE LINES	<input type="checkbox"/>	<input type="checkbox"/>	_____	_____
HVAC FILTER DOORS OPEN	<input type="checkbox"/>	<input type="checkbox"/>	_____	_____
ELECTRICAL CONDUIT DAMAGED	<input type="checkbox"/>	<input type="checkbox"/>	_____	_____
GRANULE SURFACING	<input type="checkbox"/>	<input type="checkbox"/>	_____	_____
EXCESS GRANULES; RF/GROUND	<input type="checkbox"/>	<input type="checkbox"/>	_____	_____
LOCK COAT	<input type="checkbox"/>	<input type="checkbox"/>	_____	_____
OVERSPRAY	<input type="checkbox"/>	<input type="checkbox"/>	_____	_____
TRASH REMOVED	<input type="checkbox"/>	<input type="checkbox"/>	_____	_____
SLIT SAMPLES TAKEN	<input type="checkbox"/>	<input type="checkbox"/>	_____	_____
CORE SAMPLES TAKEN	<input type="checkbox"/>	<input type="checkbox"/>	_____	_____
PHOTOS TAKEN	<input type="checkbox"/>	<input type="checkbox"/>	_____	_____

▲
NORTH

FOAM THICKNESS/SLIT SAMPLES

LOCATION	FOAM THICKNESS	COATING THICKNESS	LOCATION	FOAM THICKNESS	COATING THICKNESS
1			8		
2			9		
3			10		
4			11		
5			12		
6			13		
7			14		

NOTE ANY INSTALLATION CONDITIONS WHICH COULD CAUSE LEAKS _____

- OVERALL RATING:** 5-EXCELLENT A-1 JOB 4-GOOD A-1 JOB MINOR DEFECTS 3-ACCEPTABLE AFTER REPAIRS
 2-NOT ACCEPTABLE/REPLACEMENT OR MAJOR REPAIR 5-50% OF AREA SEE PUNCH LIST
 1-NOT ACCEPTABLE/REPLACEMENT OR MAJOR REPAIR 50% + OF AREA SEE PUNCH LIST

PROJECT OK FOR WARRANTY INSPECTION NOTIFY MANUFACTURER YES NO (CIRCLE ONE)

INSPECTED BY _____



**RESIN TECHNOLOGY
DIVISION OF HENRY
COMPANY**

PERMAX®/PERMA-PLUS ROOFING WARRANTY REQUEST - FORM WR105

SELECT TYPE & LENGTH
OF WARRANTY

MATERIAL, THEN SELECT FROM 5 + 5 YEAR 10 YEAR 10 + 10 YEAR
 SYSTEM, THEN SELECT FROM 5 YEAR 10 YEAR 20 YEAR

1.  Name of Project: _____
Address: _____
City: _____ State: _____ Zip: _____

2.  Name of Qualified Applicator: _____
Address: _____ Telephone: () _____ Fax: () _____
City: _____ State: _____ Zip: _____

3.  Owner of Building: _____
Address: _____ Telephone: () _____ Fax: () _____
City: _____ State: _____ Zip: _____
Owner's Representative: _____ Telephone: () _____ Fax: () _____

Project Technical Information

- 4. Roof Area _____ square feet
- 5. Coating Used: _____ Total Gallons Used: _____
First Coat: _____ gallons Second Coat: _____ gallons Third Coat (if required) _____ gallons
- 6. Dry Mills Required - Total: _____
- 7. Polyurethane Foam Thickness: _____
- 8. Granules: _____ single _____ double

I hereby certify that the above information has been verified, that the coating application is in accordance with Resin Technology Division Henry Company's (RTC)'s current published application instructions, that this information shall be relied upon by RTC for the purpose of issuing RTC's Roofing Warranty selected above and that the terms and conditions of the warranty shall apply to this roof.

Qualified Applicator

Signature

Printed Name

RTC INTERNAL USE: DATE RECEIVED _____ WARRANTY NO ASSIGNED W- _____



**RESIN TECHNOLOGY
DIVISION OF HENRY
COMPANY**

PERMAX® PERMA-PLUS ROOFING SYSTEM WARRANTY PRE-NOTIFICATION FORM WR106

LENGTH WARRANTY: 5 YEAR 10 YEAR 15 YEAR 20 YEAR

1. Name of Project: _____
 Address: _____
 City: _____ State: _____ Zip: _____
2. Name of Qualified Applicator: _____
 Address: _____
 City: _____ State: _____ Zip: _____
 Telephone: _____ Fax: _____
3. Owner of Building: _____
 Address: _____
 City: _____ State: _____ Zip: _____
 Telephone: _____ Fax: _____
 Owner's Representative: _____
 Telephone: _____ Fax: _____

PROJECT TECHNICAL INFORMATION

Roof Area _____ sq. ft. Photos Included Specification Attached
 Roof Plan & Details Attached
 Polyurethane Foam Density _____ Thickness Specified _____ Existing Slope _____
 Protective Coating _____ Granules Single Double Lock Coat
 Total Dry Mils Required _____ Minimum Base Coat Dry Mils _____
 Estimated Gals Required for Project _____ Base Coat System _____ Top Coat System _____ Lock Coat _____

Please identify any special conditions which differ from standard Resin Technology Division Henry Company (RTC) specifications and/or procedures. If a hybrid coating system is specified please include specification requirements and describe below. It is understood that all slope, roofing applications, instructions, and details will be installed per RTC Guidelines or as noted and approved below. This information shall be relied upon by RTC for the purpose of issuing RTC's Roofing Systems Warranty selected above and that the terms and conditions of the warranty shall apply to this roof.

APPROVED APPROVED WITH THE FOLLOWING CHANGES: _____

INDEPENDENT INSPECTION REQUIRED Project Inspection Fees _____
 Warranty Fee _____

Qualified Applicator Signature: _____
 Printed Name: _____

RTC INTERNAL USE: DATE RECEIVED _____ WARRANTY NO. ASSIGNED **W-** _____

PERMAX[®] POLYURETHANE ROOFING INSTALLATION MANUAL

This manual provides necessary installation techniques, procedures, design, and processes to provide minimum requirements to meet the RTC Permax[®] Warranty Program. Contractors, which choose to follow these guidelines in their everyday contracting business, may use this booklet as a training manual for their employees. RTC Permax[®] assumes no responsibility for Contractors which choose to incorporate these guidelines into their work beyond the specific tenants and obligations of the Permax[®] Warranty Program. If there are any questions regarding proper installation of Permax[®] materials contact your sales representative immediately or RTC/Henry at (800-729-0795).

Contractors may use this page to log the employee's names that have studied this booklet and understand its installation requirements and procedures.

Date _____ Name _____

Date _____ Name _____

Date _____ Name _____

Date _____ Name _____

Date _____ Name _____

Date _____ Name _____

Date _____ Name _____

Date _____ Name _____



Henry
C O M P A N Y [®]

#1 CHOICE OF PROFESSIONALS[®]

HENRY COMPANY / RESIN TECHNOLOGY

2270 Castle Harbor Place

Ontario, CA 91761

(909) 947-7224 (800) 729-0795 FAX (909) 923-0617

www.permax.com