

# SL150 Standing Seam

(formerly CSL)

## Installation Manual



PO Box 229  
Fayetteville, NC 28302



[www.unionmetalroofing.com](http://www.unionmetalroofing.com)



Toll-Free  
(888) MTL-ROOF



## IMPORTANT NOTICE

**This manual contains suggestions and guidelines on how to install the subject Union Corrugating panels and trim details. The contents of this manual include the guidelines that were in effect at the time this publication was originally printed. In an effort to keep pace with the ever-changing code environment, Union Corrugating retains the right to change specifications and / or designs at any time without incurring any obligations. To insure you have the latest information available, please inquire or visit our web site. Application and design details are for illustrative purposes only and may not be appropriate for all environmental conditions and/or building designs. Projects should be engineered and installed to conform to applicable building codes, regulations, and accepted industry practices.**



## TABLE OF CONTENTS

Introduction, Tools, Safety, & Packaging .....	3-4
Storage & Handling .....	5-7
Field Cutting .....	8
Design & Installation Considerations .....	8-9
CSL Accessories & Trim Profiles .....	10-11
Panel Installation .....	12
Trim Installation & Details .....	13-24
Vented Ridge .....	13
Flat Hip & Ridge .....	14
Single Sloped Ridge .....	15
Plumb Eave .....	16
Hemmed Floating Rake .....	17
Floating Rake .....	18
Fixed Rake .....	19
Valley .....	20
Side Wall .....	21
End Wall .....	22
Transition .....	23
Mansard Transition .....	24



# CSL PANEL

## INTRODUCTION

The CSL (Clipped Snap Lock) Standing Seam panel is a popular 1.5" rib style that installs with concealed clips. Because of their installation methods, CSL Panels can "float" on the roof deck allowing for maximum expansion and contraction. The CSL Standing Seam panel is designed to be installed over a solid deck on roof pitches of 3 on 12 and greater. With proper handling and installation, your CSL panels will provide years of leak-free performance and beauty. Please review this manual carefully and completely before beginning your installation.

### Applications:

CSL is an architectural (non-structural) panel that is ideal for commercial and residential applications. It can be used for roofing, mansards, or fascias. The panels must be applied over a solid substrate. Green, wet and treated wood should not be used in direct contact with any CSL panels.

### Available Specifications:

#### Colors and Finishes:

The CSL panel is available in 26 or 24 ga steel. 26 ga panels use our 40 yr SMP paint system and 24 ga panels use a PVDF (Kynar®) system. Warranty copies are available upon request.

#### Widths:

The CSL panel is available in 16" coverage width. The 1/16" striations provide strength and reduce the incidence of oil canning in the panel.

#### Lengths:

The CSL Panel is available in standard lengths from 3' to 40'. Longer lengths require additional handling, packaging, and shipping considerations. An extra handling charge may apply to panels over 40'. Please consult your local Union Corrugating office for recommendations. CSL panels can be end lapped.

#### Rib Height:

The full 1.5" high rib provides for improved leak resistance over other typical panels. Some prefer this higher rib for the finished look it presents.



## DESIGN

This manual contains suggestions and guidelines on how to install CSL panels. The installation details shown are proven methods of construction, but are not intended to cover all instances, building requirements, designs, or codes. It is the responsibility of the designer/installer to ensure that the details meet particular building requirements. The designer/installer must be aware of, and allow for, expansion/contraction of roof panels. The details may require changes or revisions due to each project's conditions.

There are certain minimum wind loads and snow loads that a roof must generally be designed to support. Consult local building officials to determine the appropriate building design load requirements. A professional engineer should be consulted for all roof system designs. It is the buyer's responsibility to verify all applicable code requirements, check all measurements, and determine suitability of product for job. Any job estimates or take-offs provided by Union Corrugating are for reference only. The buyer is responsible for verifying actual length and quantities needed. Implied warranties of merchantability and fitness for a particular purpose are disclaimed. All CSL instructions assume that a qualified firm or individual has been contacted regarding applications of this product. Failure to comply with stated recommendations relieves the manufacturer of responsibility for any damage or deterioration of the product incurred and voids any applicable warranty.

## TESTING

Florida Building Code High Velocity Hurricane Zone  
Approval #FL 9443

UL 580 - Construction No: 589  
UL Class 4 Impact  
ASTM 331  
ASTM E-330  
ASTM 1592  
ASTM 283



# CSL PANEL

## TOOLS & EQUIPMENT

- Cordless Screw Gun
- Snips
- Tape Measure
- Electric Metal Shear \*
- Caulk Gun
- Pop Rivet Tool
- Chalk Line
- "Duckbill" Locking Pliers
- Hemming Tool
- Electrical Extention Cord #14

\* We do not recommend the use of a circular saw.

Use of a power saw could:

1. Increase the probability of edge rust.
2. Metal particles on panel surface could damage panel finish.

Installer must have prior experience and knowledge of the listed tools and their uses in working with metal roofing.

## SAFETY

If you must walk on a metal roof, take great care. Metal panels can become slippery, so always wear shoes with non-slip soles. Avoid working on metal roofs during wet conditions when the panels can become extremely slippery. Walking or standing on a metal roof which does not have a plywood or other deck beneath it is not recommended. However, if you must do so, always walk on the purlins, never between.

OSHA safety regulations should be complied with at all times.

### ⚠ CAUTION ⚠

Always wear heavy gloves when working with steel panels to avoid cuts from sharpe edges. When power cutting or drilling steel panels, always wear safety glasses to prevent eye injury from flying metal fragments.

## DELIVERY & PACKAGING OPTIONS

### Lead Time:

Please allow 14 days for delivery for standard colors. Any special requests or non-standard colors may require longer lead times. Consult your local Union Corrugating sales representative for special requests.

### Packaging:

A packaging charge will be added to all orders. Standard packaging is crating for all orders.

For LTL and overseas shipments, panels are packaged in a completely enclosed crate to provide optimum protection. Additional charges will apply for non-standard packaging and special requests.

### Standard Packaging

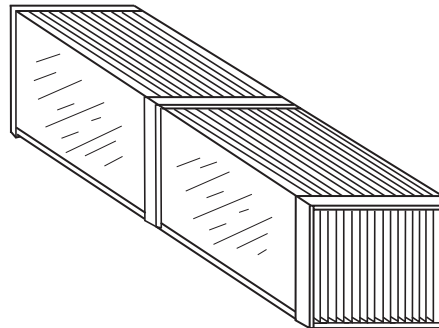

### Optional Packaging

Full Crate - This method is utilized for all LTL and overseas shipments or at customer's request.

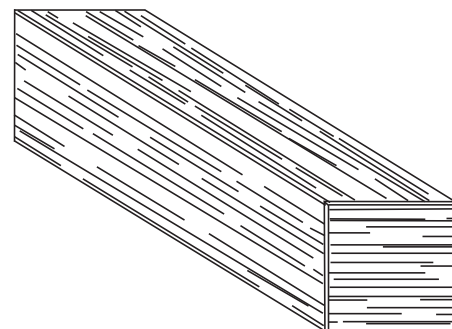

## STORAGE & HANDLING

### Storage:

Bare Galvalume® and painted panels can be expected to give many years of rust-free service when precautions are taken during storage.

If metal is not to be used immediately, store inside in a well-ventilated, dry location. **Any outdoor storage is at the customer's own risk!** At time of delivery, inspect panels for moisture. If moisture has formed, the panels should be uncrated, wiped dry, and allowed to dry completely. Failure to remove the entrapped moisture between the sheets immediately will affect the service life of the metal. Extended storage of panels in a bundle is not recommended. Under no circumstances should the sheets be stored near or come in contact with salt water, corrosive chemicals, ash, or fumes generated or released inside the building of nearby plants, foundries, plating works, kilns, fertilizer, and wet or green lumber.

### If panel bundles must be stored outside, the following list of requirements must be adhered to:

1. The storage area should be reasonably level, and should be located so as to minimize handling of crates during the construction process.
2. When stored on bare ground, place a plastic ground cover under the crates to minimize condensation on the panels from moisture in the soil.
3. Store crates at least 6 inches above the ground level to allow air circulation beneath the bundle, and to prevent rising water from entering the bundle.
4. Elevate one end of the crate slightly to permit runoff of moisture from the top of the bundle or from between nested panels. A water-resistant cover, like canvas, should be placed over the crates, with allowance for air circulation under the cover. The cover should be blocked off of the crate. (see Figure 1)

5. Inspect stored crates daily and repair any tears or punctures in the water-resistant cover with a compatible waterproof tape.
6. Re-cover opened crates at the end of each day to prevent entry of moisture and exposure to sunlight.

### Polyfilm Removal:

The panels may have a protective polyfilm layer applied to the topside of the panel to prevent possible damage to the painted surface. If panel has a protective polyfilm coating, remove the polyfilm before exposing to direct sunlight and high temperatures. After exposure to sunlight, the polyfilm cannot be removed. Under no circumstances should the polyfilm remain on the panels after installation. Union Corrugating bears no responsibility for damage to metal caused by improper storage and failure to remove polyfilm.

### Storage on Roof:

To facilitate the handling of CSL panels, panel crates can be lifted and placed on the roof. Crates need to be placed parallel to the framing members and the slope of the roof. Load capabilities of the structure must be checked prior to placing crates on the roof.

When lifting packaged sheets, make sure they are adequately supported. Panels less than 20' in length can normally be lifted with a forklift; however, when lifting panels in excess of 20', it is recommended that a spreader bar and slings be used. When lifting, no more than 1/3 of the length of the panel should be left unsupported.

Make a plan for bundle placement determining how much area a bundle of panels will cover. Bundles should be placed on the roof in accordance with the direction the panel will be installed. Consider where the string line, if any, is to run at the eave to set roof panels by. Roof bundles should not interfere with this string line. (see Figure 2)

Any outdoor storage of panels is at the customer's own risk!

Fig. 1

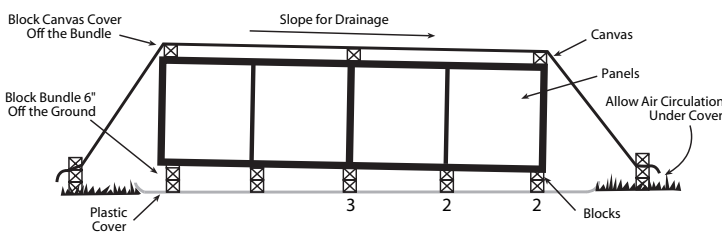
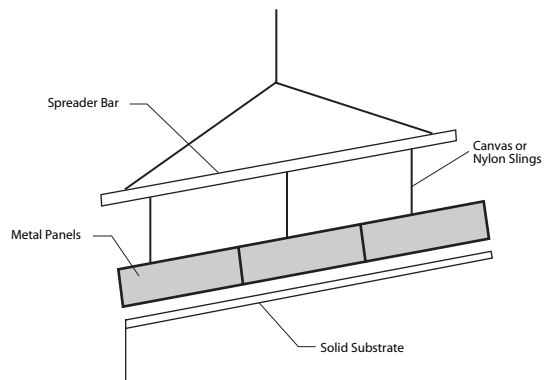

Fig. 2



## STORAGE & HANDLING

### Receiving Materials:

It is the responsibility of the installer to unload material from the delivery truck. The installer shall be responsible for providing suitable equipment for unloading of material from the delivery truck.

After receiving material, check the condition of the material, and review the shipment against the shipping list to ensure all materials are accounted for. If damages or shortages are discovered, it should be noted on the shipping copy at time of delivery. If material is delivered by common carrier, a claim must be made with the carrier as soon as possible. If replacement material is required, you must contact Union Corrugating to place the order. If material is delivered on company trucks, note the damages and shortages on the shipping copy. Any damages and shortages must be reported to Union Corrugating within 48 hours from the time of shipment.

- After crates are opened, individual panels must also be handled carefully to prevent panel buckling or damage to the panel coating. When removing a panel from a crate, it should never be allowed to slide over another panel. The individual panels should be "rolled" out of the crate in order to minimize the chance of panel damage.
- Soft gloves must be worn when handling panels.

### Manual Handling:

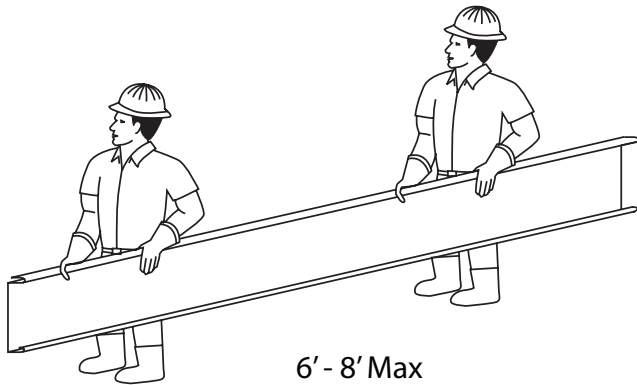

**⚠ CAUTION ⚠**

Improper loading and unloading of crates may result in bodily harm and/or material damage. Union Corrugating is not responsible for bodily injuries and/or material damages resulting from improper loading and unloading.

### General Handling:

Each crate should be handled carefully to avoid being damaged. Care should be taken to prevent bending of the panel or abrasion to finish. Please follow these steps for proper care while unloading and handling crates in order to prevent panel damage:

- Crates should remain intact during any handling, and until the individual panels in each bundle are ready to be installed. Crates should never be lifted by the banding.
- Lift each crate as close as possible to its center of gravity.
- If the crates are to be lifted with a crane, use a spreader bar of appropriate length, and nylon band slings. (Do not use wire rope slings as they will damage the panels)
- Depending on panel length, some crates may be lifted by a forklift. When using a forklift, the forks should be spread apart to their maximum spacing, and the load must be centered on the forks to prevent scratching the next panel. A panel should never be picked up by its ends. Instead, lift the panel along its longitudinal edge and carry in a vertical (not flat) position. For panels over 10 feet long, two or more people should lift the panel along the same edge.

### Incorrect

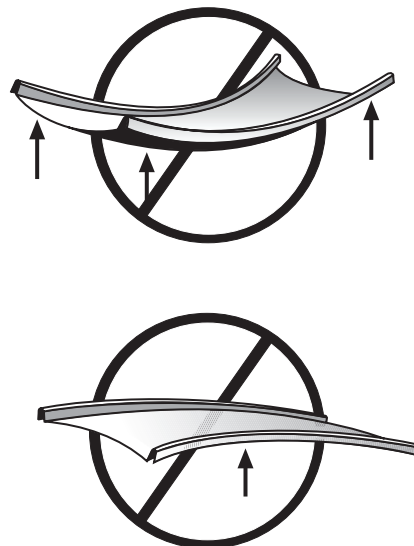

## Mechanical Handling:

### Forklift

A forklift may be used for panels up to 20' long. Please make sure the forks are at their maximum separation. Do not transport open crates. When transporting crates across rough terrain, or for a long distance, some means of supporting the panel load must be used.

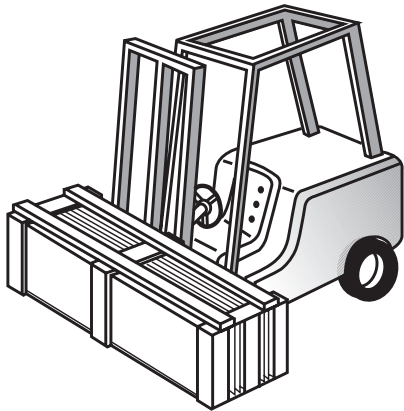

### Crane

A crane should be used when lifting panels with lengths greater than 20'. Please be sure to utilize a spreader bar to ensure the even distribution of the weight to the pick up points. As a rule, when lifting panels, no more than 1/3 of the length of the panel should be left unsupported. Canvas or nylon slings should be used to pick up panels. DO NOT use cable or chains because this will damage the panels.

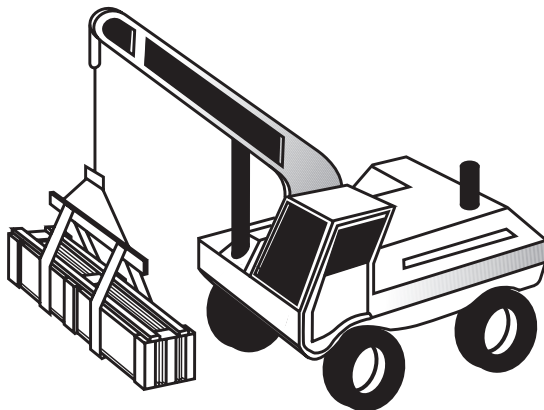

## FOOT TRAFFIC

Care of metal panels and flashings must be exercised throughout erection. Foot traffic can cause distortion of panel and damage to finish. Traffic over the installed system must be kept to an absolute minimum. If continuous foot traffic is necessary for maintenance over certain areas of the roof, then a permanent walkway should be installed.

If continuous foot traffic is necessary during installation, provide walking platforms to avoid any panel damage as shown below:

When walking on the roof panels is unavoidable, walk only in the flats of the panel as shown below. Walking on the ribs can cause damage to the panels.

## ⚠ CAUTION ⚠

All applicable safety regulations, including OSHA regulations, must be complied with during the panel installation process.

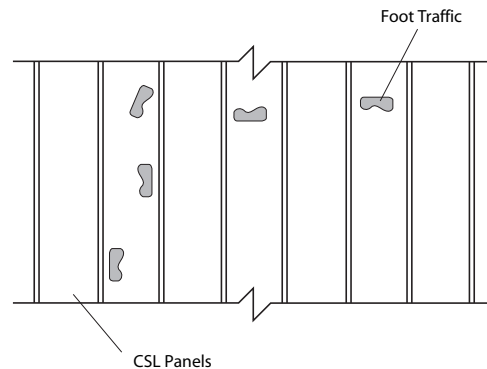
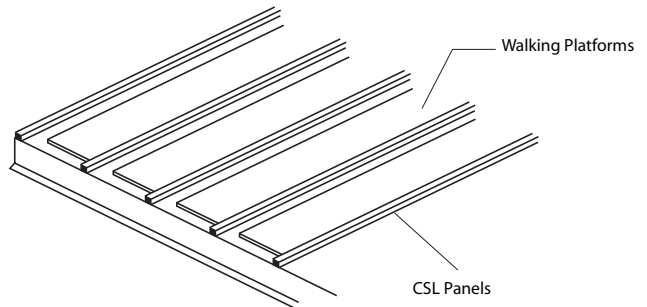



## FIELD CUTTING

Tin snips or a “nibbler” type electric tool are recommended for field cutting CSL panels. If a skill saw is used, the blade will generate slivers of metal chips. Any slivers of metal chips must be immediately removed from the CSL panels because they will damage the finish and shorten the life of the product.

One method of preventing this problem is to flip the panels over when cutting. This allows the slivers of metal chips to be brushed from the back side and avoids damaging the paint on the top side of the panels.

### ⚠ CAUTION ⚠

All product surfaces should be free of debris at all times. Installed surfaces should be wiped clean at the end of each work period. Never cut panels over metal surfaces. Metal shavings will rust on the surface thus voiding the warranty.

### ⚠ CAUTION ⚠

When cutting metal panels, goggles must be worn for eye protection.

## TOUCH-UP PAINT

All painted panels and flashings have a factory applied baked on finish. Handling and installing panels may result in some small scratches or nicks to the paint finish. Touch-up paint is available in matching colors. It is recommended that a small brush be used to apply touch-up paint to those areas that are in need of repair. Touch-up paint does not have the superior chalk and fade resistance of the factory applied paint finish and will normally discolor at an accelerated rate. Aerosol paint should not be used because of the overspray that may occur. Periodic touch-up may be required to maintain color match. There is no warranty on touch-up paint in regards to colormatch because the paint processes are different.



Touch-Up Paint

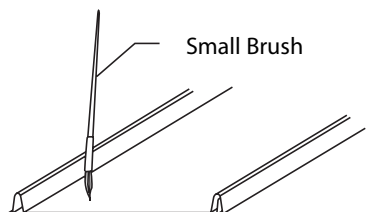

Small Brush

## DESIGN CONSIDERATIONS & CALCULATIONS

### Insulation & Ventilation:

Proper design and installation of vapor barriers and ventilation systems are important to prevent condensation and the resulting problems of moisture damage and loss of insulation efficiency.

Condensation occurs when moisture-laden air comes in contact with a surface temperature equal to or below the dew point of the air. This phenomenon creates problems that are not unique with metal buildings; these problems are common to all types of construction.

In addition to providing resistance to heat transfer, insulation can also protect against condensation forming on cold surfaces, either inside the building or within the wall/roof system cavity. The arrangement of the building’s insulation system and vapor retarder is the responsibility of the building designer. These are some basic guidelines to help control condensation in a metal building:

1. The insulation should have a vapor retarder face on the “warm” side of the insulation. For most buildings, this means that the vapor retarder is on the inside surface (toward the building’s interior)
2. The thickness of the insulation must be designed to maintain the temperature of the vapor retarder above the interior dew point, using the worst-case expected outside temperature.
3. All perimeter conditions, seams, and penetrations of the vapor retarder must be adequately sealed in order to provide a continuous membrane to resist the passage of water vapor.
4. Building ventilation, whether by gravity ridge vent, power operated fans, or other means, contributes significantly to reduce condensation. The movement of air to the outside of the building reduces the interior level of vapor pressure.

On buildings that have an attic space or are being retrofitted with a metal roofing system, vents should be placed at both ends of the eave and peak of the roof in order to prevent a buildup of moisture (humidity) in the attic space

Contact your local building code officials or an engineer on proper ventilation practices for your area.

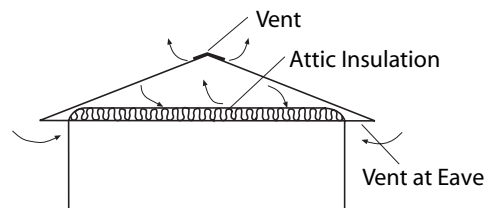

## DESIGN/INSTALLATION CONSIDERATIONS

### Substrates:

**Warm Weather Note:** In warm weather and tropical climates, Union REPEL synthetic underlayment should be used over the existing substrate. The high temperature resistance of REPEL prevents it from sticking to the panels and tearing, which can occur with asphalt-based felt paper.

**Cold Weather Note:** In cold weather climates, it is recommended that you use and Ice and Water Shield at the valley and eave. This needs to be applied over the substrate before the REPEL synthetic underlayment is installed.

**⚠ CAUTION ⚠**  
 Extreme caution should be used when applying these products because they can be slippery.

### ROOF PITCH FACTOR CHART

This chart should be used when specifying and ordering CSL Panels and Trims.

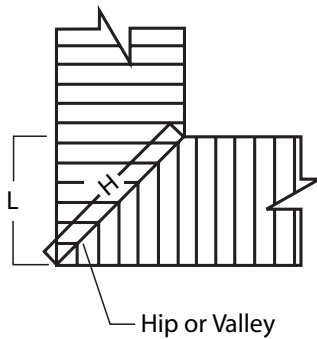

$$(L) \times (\text{Hip Valley Multiplier}) = H$$

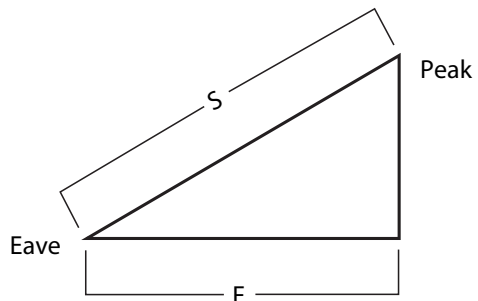

$$(F) \times (\text{Pitch Factor}) = S$$

PITCH	PITCH FACTOR	HIP/VALLEY MULTIPLIER	PITCH	PITCH FACTOR	HIP/VALLEY MULTIPLIER
3:12	1.0308	1.4362	8:12	1.2019	1.5635
4:12	1.0541	1.4530	9:12	1.2500	1.6008
5:12	1.0833	1.4743	10:12	1.3017	1.6415
6:12	1.1180	1.5000	11:12	1.3566	1.6853
7:12	1.1577	1.5298	12:12	1.4142	1.7320

## CSL ACCESSORIES

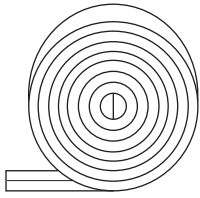

DBBTLSTLST  
Double Bead Butyl Tape  
(7/8" x 3/16" x 40')

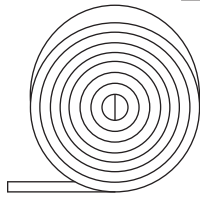

BTLSTLST  
Single Bead Butyl Tape

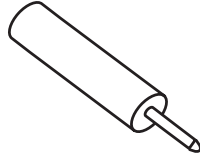

TUBESEALANT  
Urethane Tube Sealant  
(10.3 oz.)



cccPAINTTUP.6OZ  
Touch Up Paint with Brush  
(.6 oz.)



cccSSPR.125  
Pop Rivet (stainless)  
1/8" x 3/16"



GLTEK  
# 14 x 7/8"  
Hex Head  
Lap Tek Screw  
Metal-to-Metal  
Connection



cccWS150  
# 9 x 1-1/2"  
Hex Head  
Woodmate Screw  
Metal-to-Wood  
Connection



GPHWS100250  
#10 x 1" Pancake Head  
Woodscrew



GPHWS200250  
2" Pancake Head  
Woodgrip

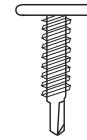

GPHDS100250  
1" Pancake Head  
Tek Screw

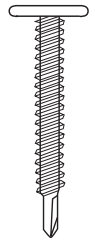

GPHWS250250  
2-1/2" Pancake Head  
Tek Screw

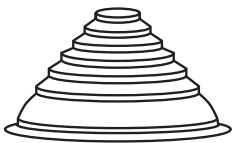

MF3  
Pipe Boot  
Various Sizes, Heat  
Treated & Retro Fit  
Also Available

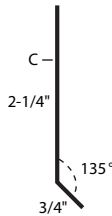

cccALCLEAT  
Cleat (1)

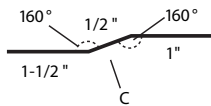

cccALOSCLEAT  
Offset Cleat (1)(2)

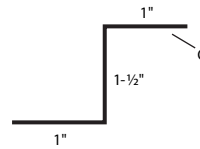

cccCSLZC  
CSLZ-Closure (1)

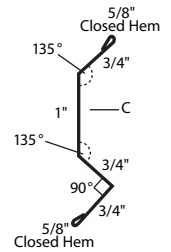

cccALCF  
Counter Flashing (1)

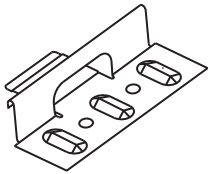

G1.5CLIP  
CSL Panel Clip

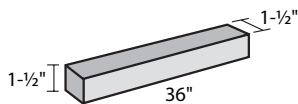

RCALUNIVERSAL  
Neoprene  
Universal Closure



cccPV2029  
cccGPV2026  
Roll Valley  
20' x 50'

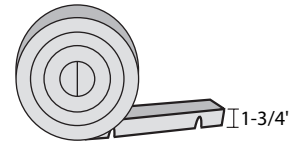

VRCCSL  
Vented Ridge  
Closure

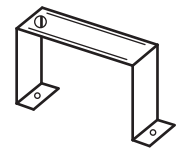

CSLVCANCHORCLIP  
Vented Ridge  
Anchor Clip

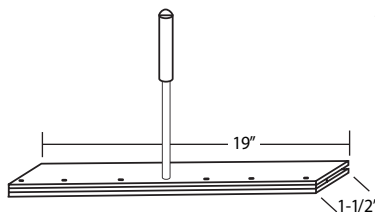

HEMMINGTOOL19  
Hemming Tool  
1/8" Opening

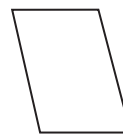

26ga 41-9/16" x 10' - cccPFS26415120 or GAFS2644120  
24ga 27-3/8" x 10' - cccPFS24275120 or GAFS24275120  
Flat Sheet

- (1) Available in 10' lengths
- (2) 26 ga only
- C Colored side.

<h3>VALLEY</h3> <p>ITEM # ccc20PV </p> <p>Blank Width 20" Also available without hems.</p>		<h3>PITCH CHANGE</h3> <p>ITEM # cccALTF </p> <p>Blank Width 13-3/4"</p> <p>Note: When the pitch difference between roofs is 2/12 or less, a custom trim must be used.</p>		<h3>END WALL</h3> <p>ITEM # cccALEWF </p> <p>Blank Width 10-1/4"</p>			
<h3>BOX RAKE</h3> <p>ITEM # cccALRAKE</p> <p>Blank Width 10-1/4"</p>		<h3>FLOATING RAKE</h3> <p>ITEM # cccCLSRKE</p> <p>Blank Width 10-1/4"</p>		<h3>SIDE WALL</h3> <p>ITEM # cccCLSW</p> <p>Blank Width 6"</p>		<h3>1.5" SILL/HEAD</h3> <p>ITEM # cccALSILLHEAD</p> <p>Blank Width 6-7/8"</p>	
<h3>FLAT HIP</h3> <p>ITEM # cccALFH </p> <p>Blank Width 13-3/4"</p>		<h3>STEP HIP</h3> <p>ITEM # cccALSH </p> <p>Blank Width 13-3/4"</p>		<h3>SILL TO SOFFIT</h3> <p>ITEM # cccALSSOFT</p> <p>Blank Width 10-1/4"</p>			
<h3>FLAT RIDGE</h3> <p>ITEM # cccALFR </p> <p>Blank Width 13-3/4"</p>		<h3>STEP RIDGE</h3> <p>ITEM # cccALSRC </p> <p>Blank Width 13-3/4"</p>		<h3>SINGLE SLOPE RIDGE</h3> <p>ITEM # cccALSSR </p> <p>Blank Width 12-1/2"</p>			
<h3>FLUSH EAVE</h3> <p>ITEM # cccALSE </p> <p>Blank Width 8-1/4"</p>		<h3>SQUARE EAVE/RAKE</h3> <p>ITEM # cccALSQE </p> <p>Blank Width 8-1/2"</p>		<h3>PLUMB EAVE</h3> <p>ITEM # cccALPE </p> <p>Blank Width 8-1/2"</p>			

All Trim Available in 10' Lengths. All open hems are designed to work with the Z-Closure. C = Colored side.

## PANEL PROFILE & INSTALLATION

cccGCSL

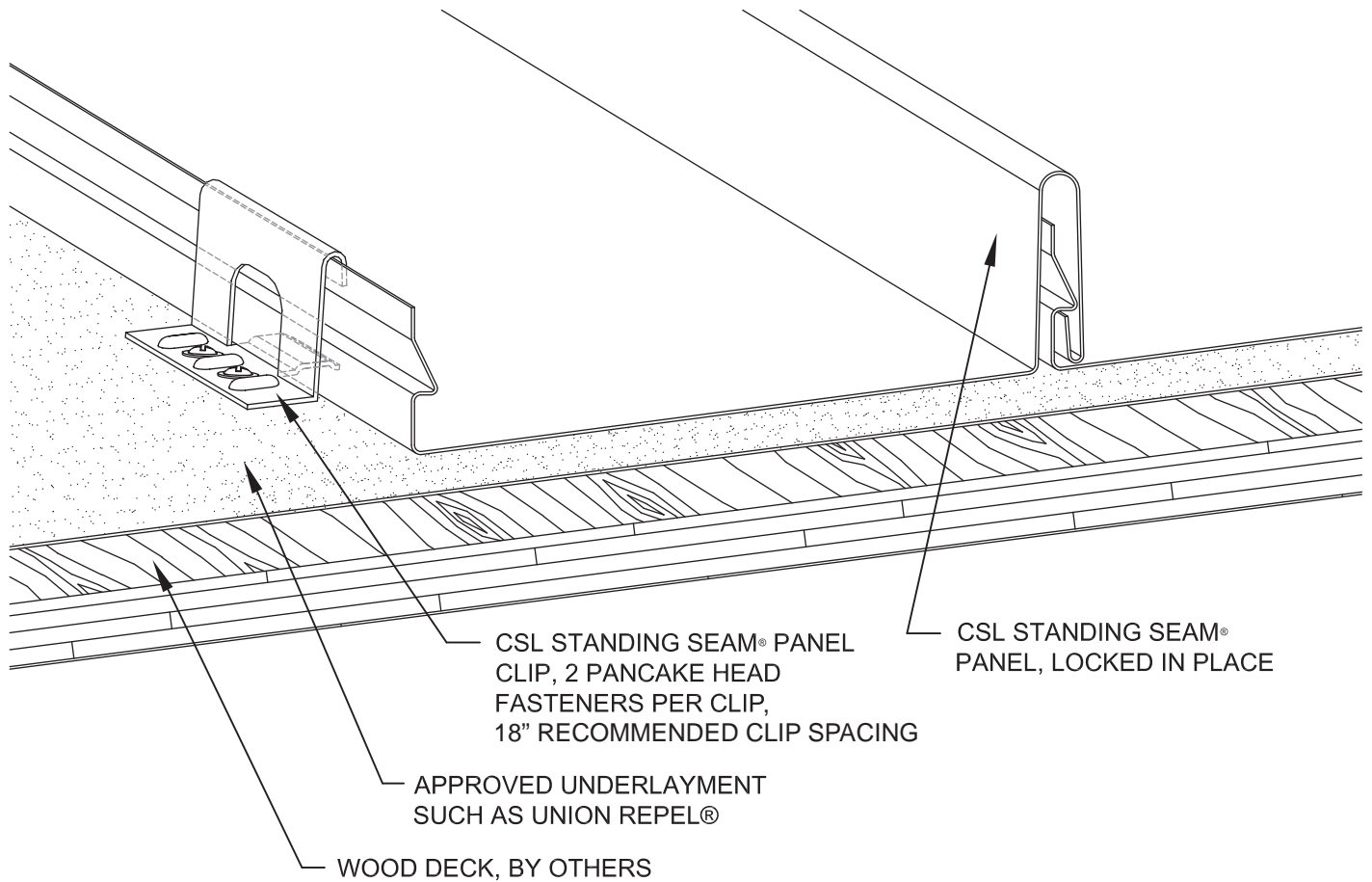
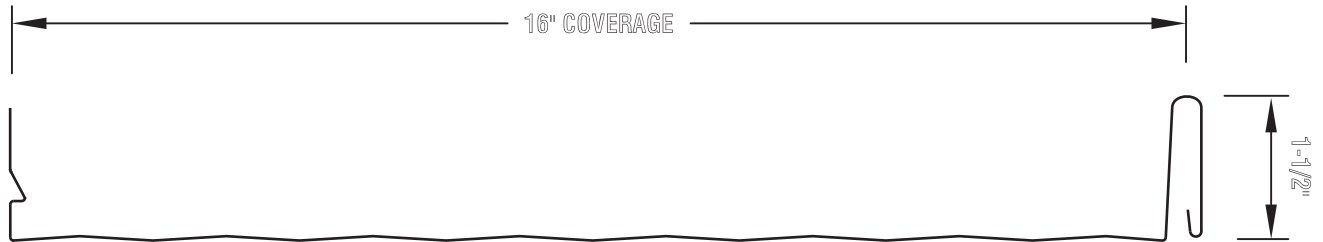

### CROSS SECTION OF PANEL FASTENING

## VENTED RIDGE

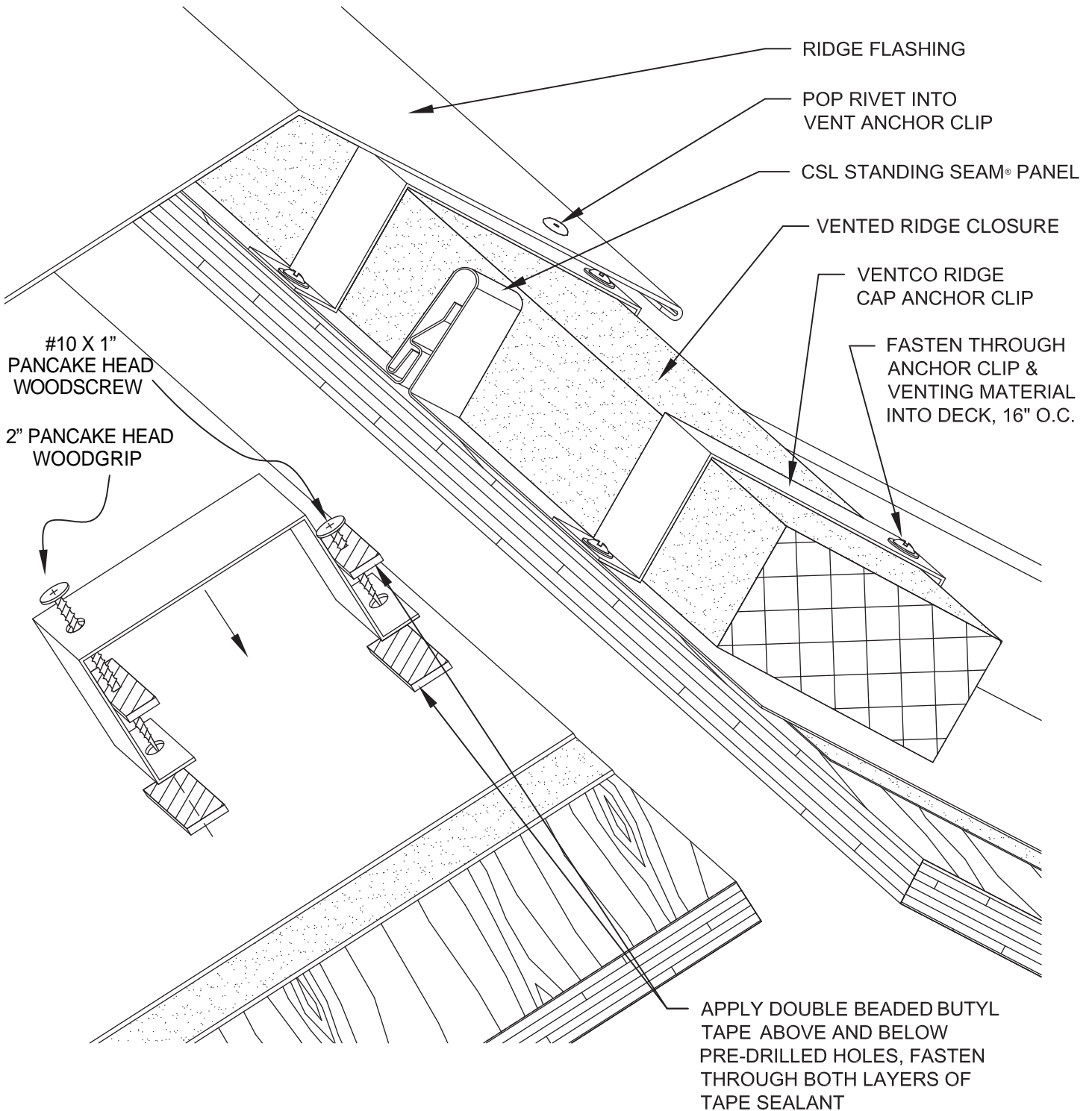

RIDGE FLASHING

POP RIVET INTO VENT ANCHOR CLIP

CSL STANDING SEAM® PANEL

VENTED RIDGE CLOSURE

VENTCO RIDGE CAP ANCHOR CLIP

FASTEN THROUGH ANCHOR CLIP & VENTING MATERIAL INTO DECK, 16" O.C.

#10 X 1" PANCAKE HEAD WOODSCREW

2" PANCAKE HEAD WOODGRIP

APPLY DOUBLE BEADED BUTYL TAPE ABOVE AND BELOW PRE-DRILLED HOLES, FASTEN THROUGH BOTH LAYERS OF TAPE SEALANT

## FLAT HIP & RIDGE

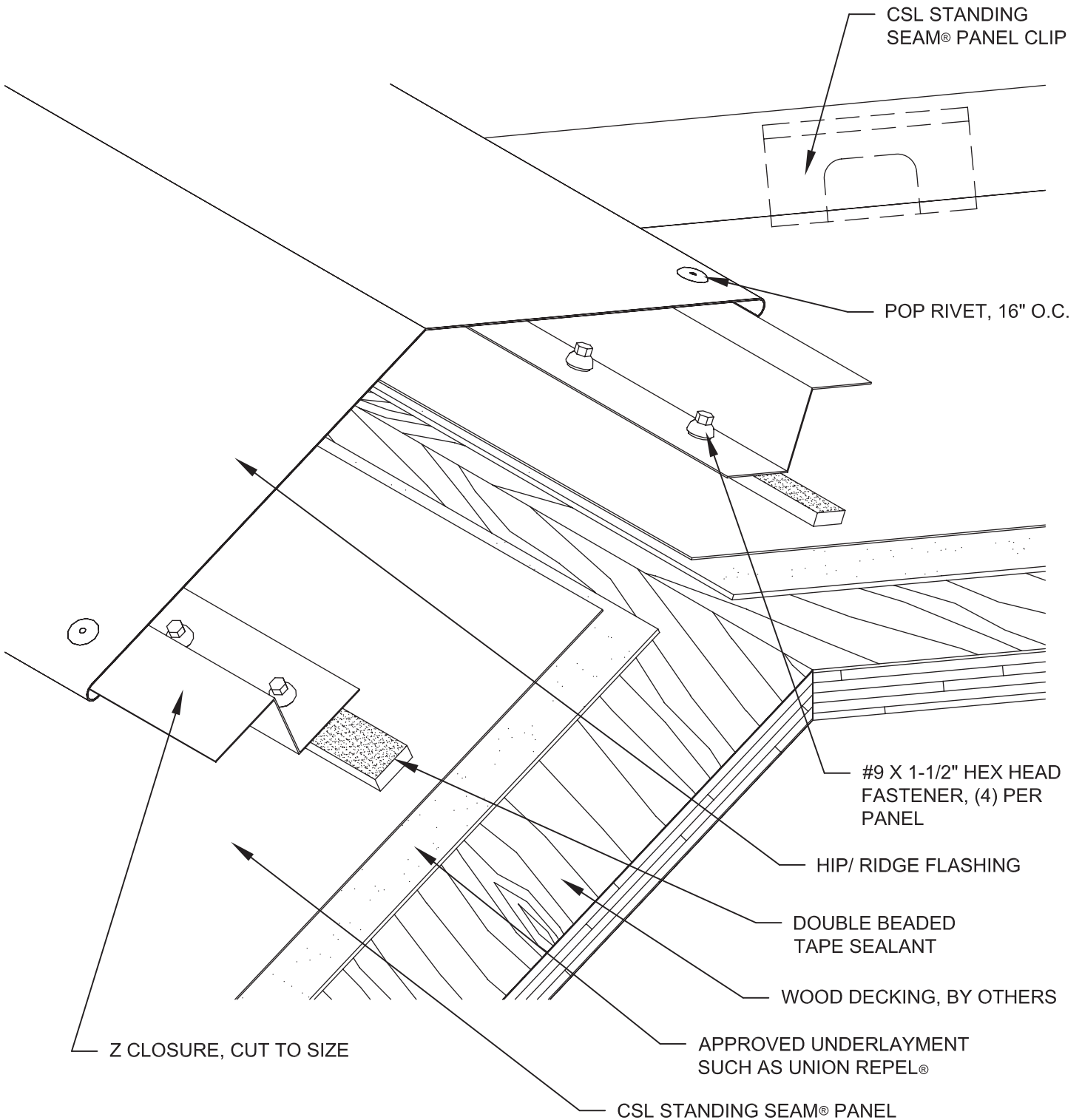

## SINGLE SLOPED RIDGE

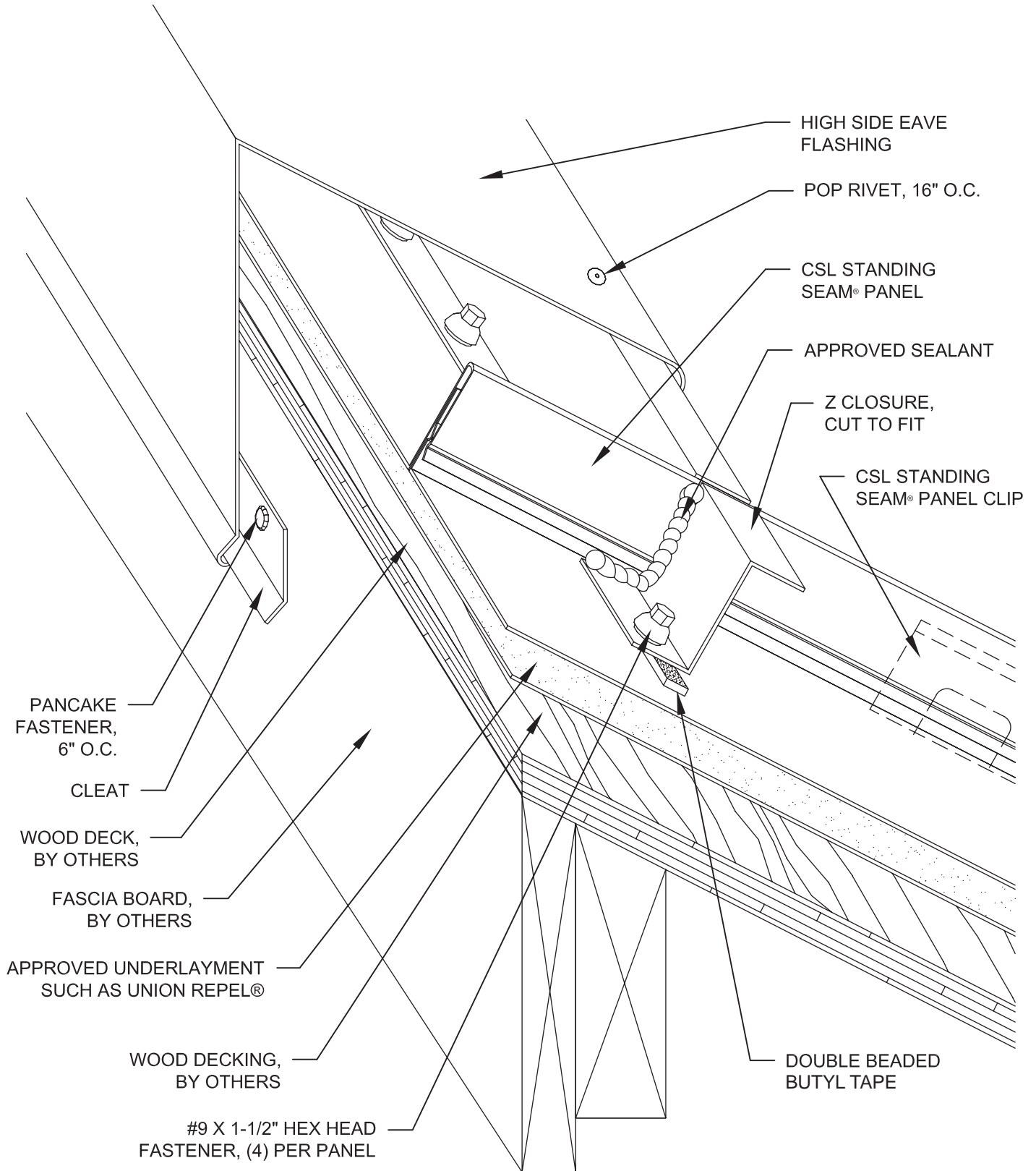



## PLUMB EAVE

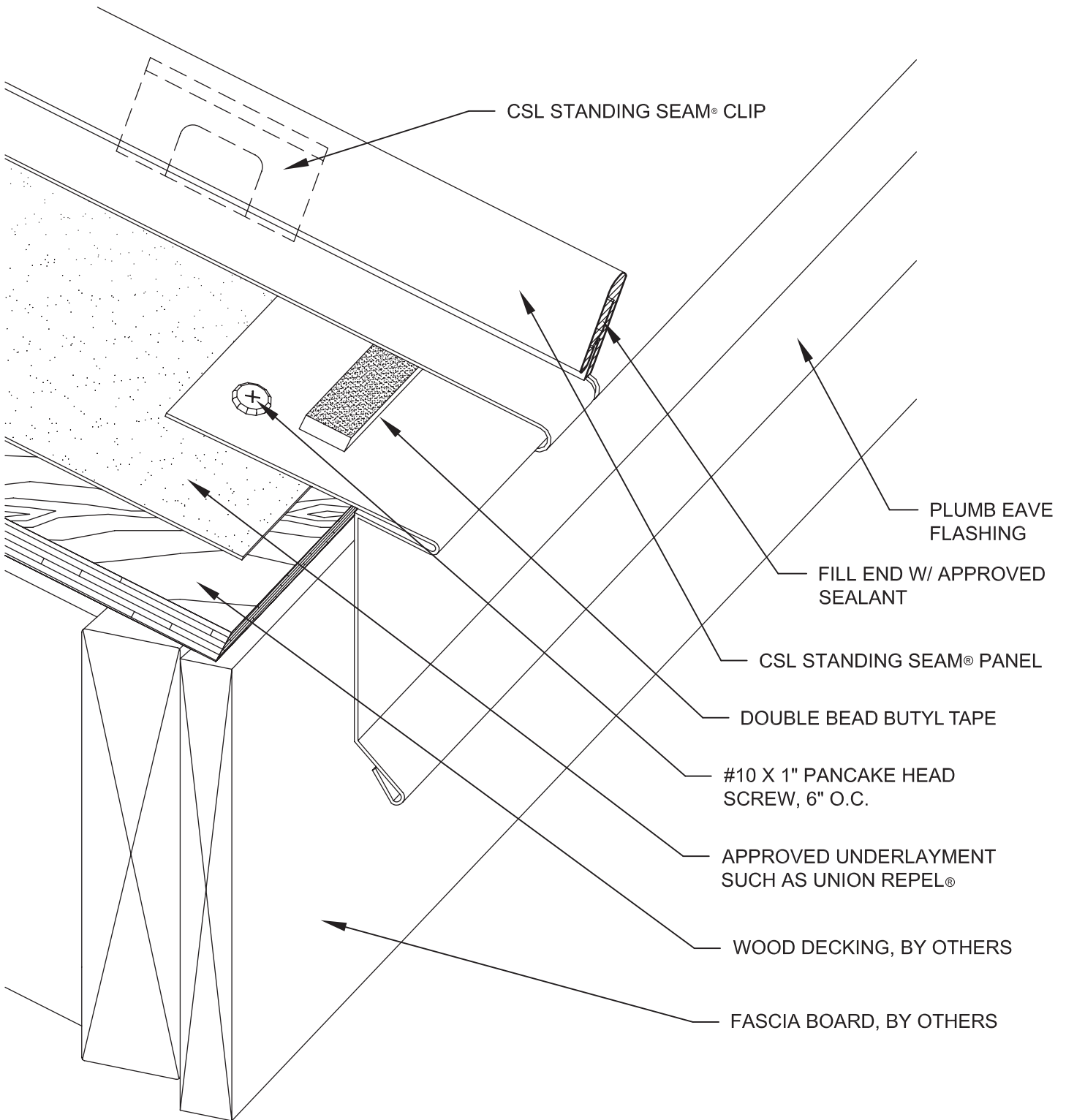

## HEMMED FLOATING RAKE

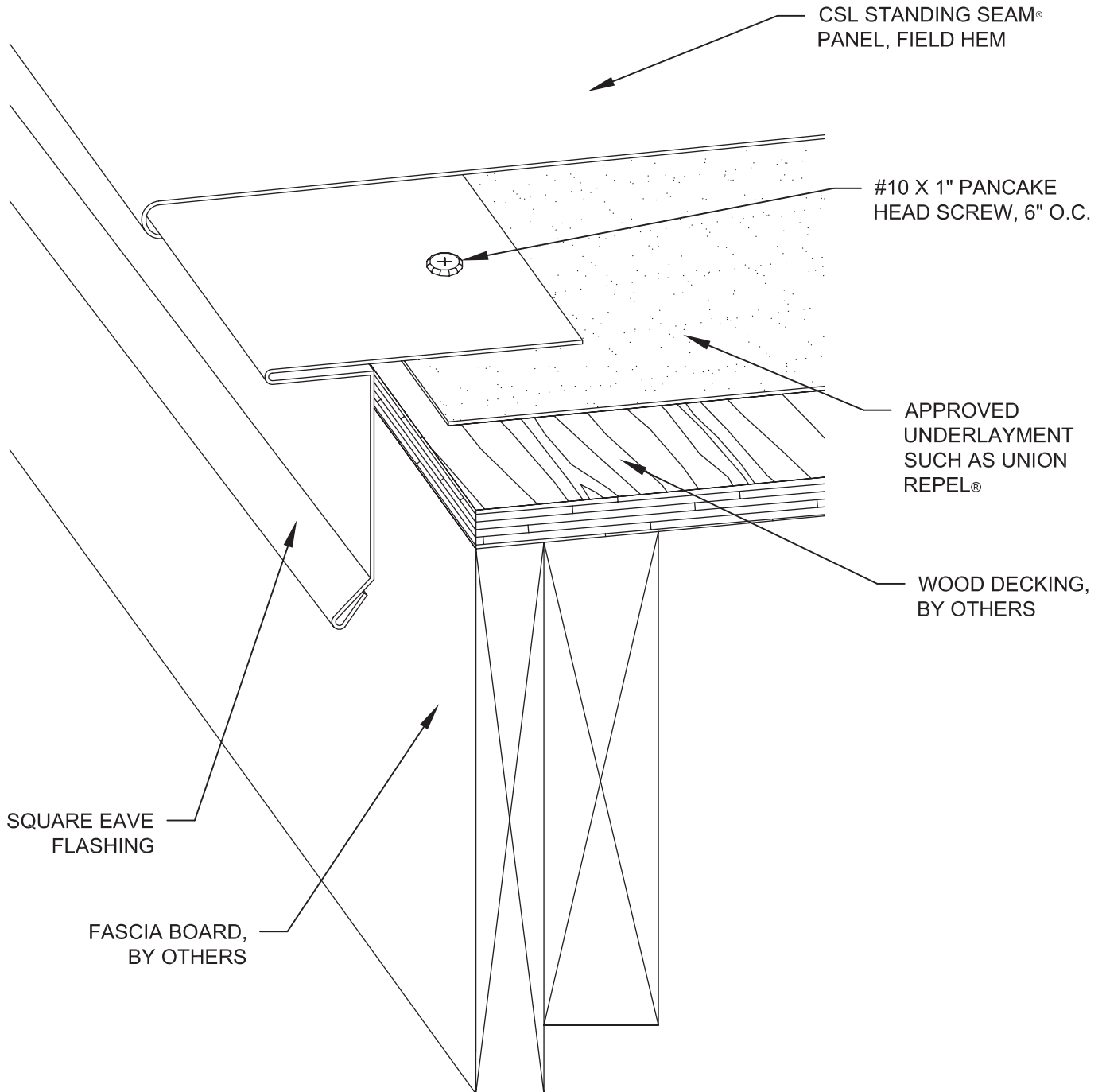

## FLOATING RAKE

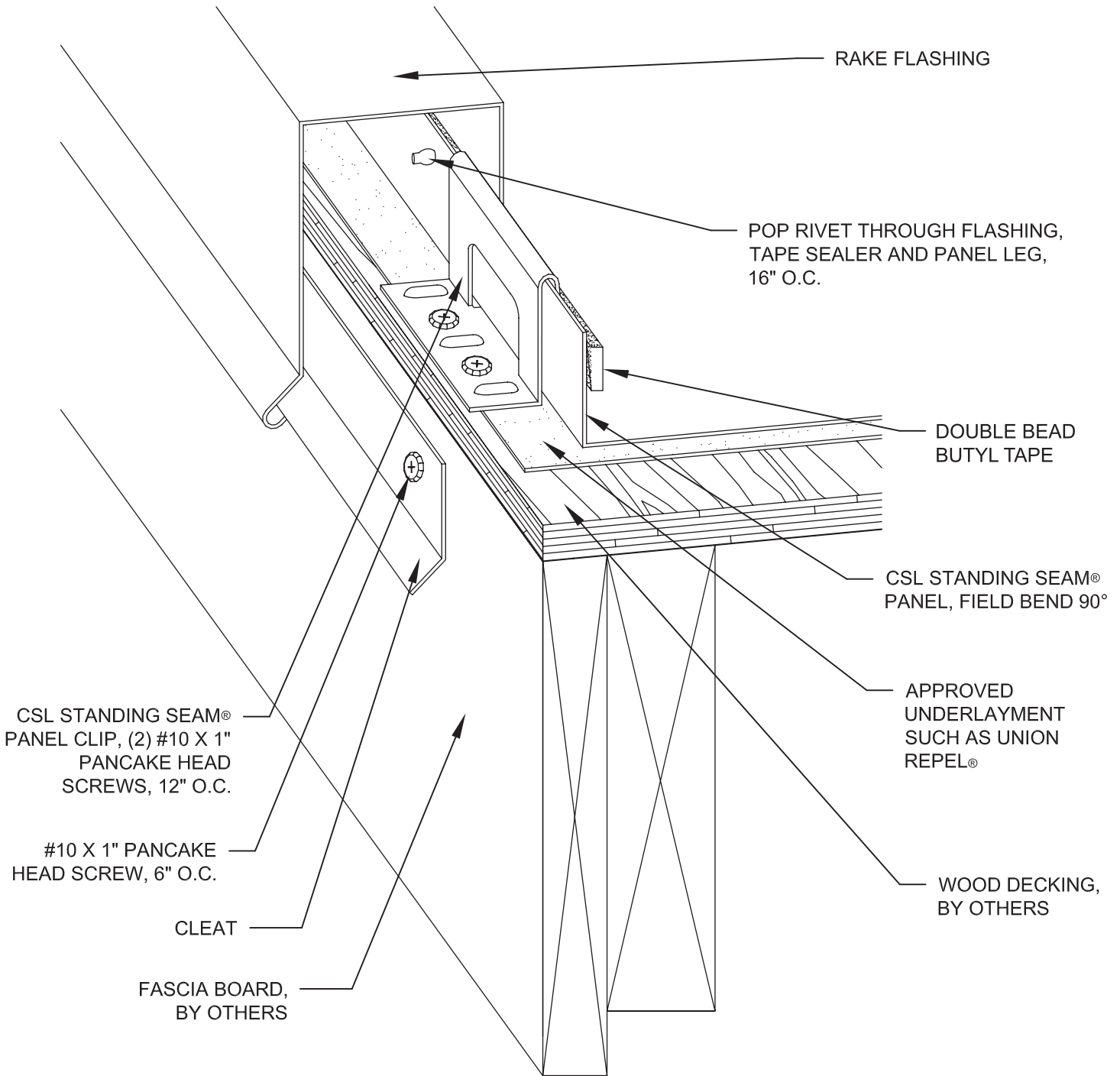

## FIXED RAKE

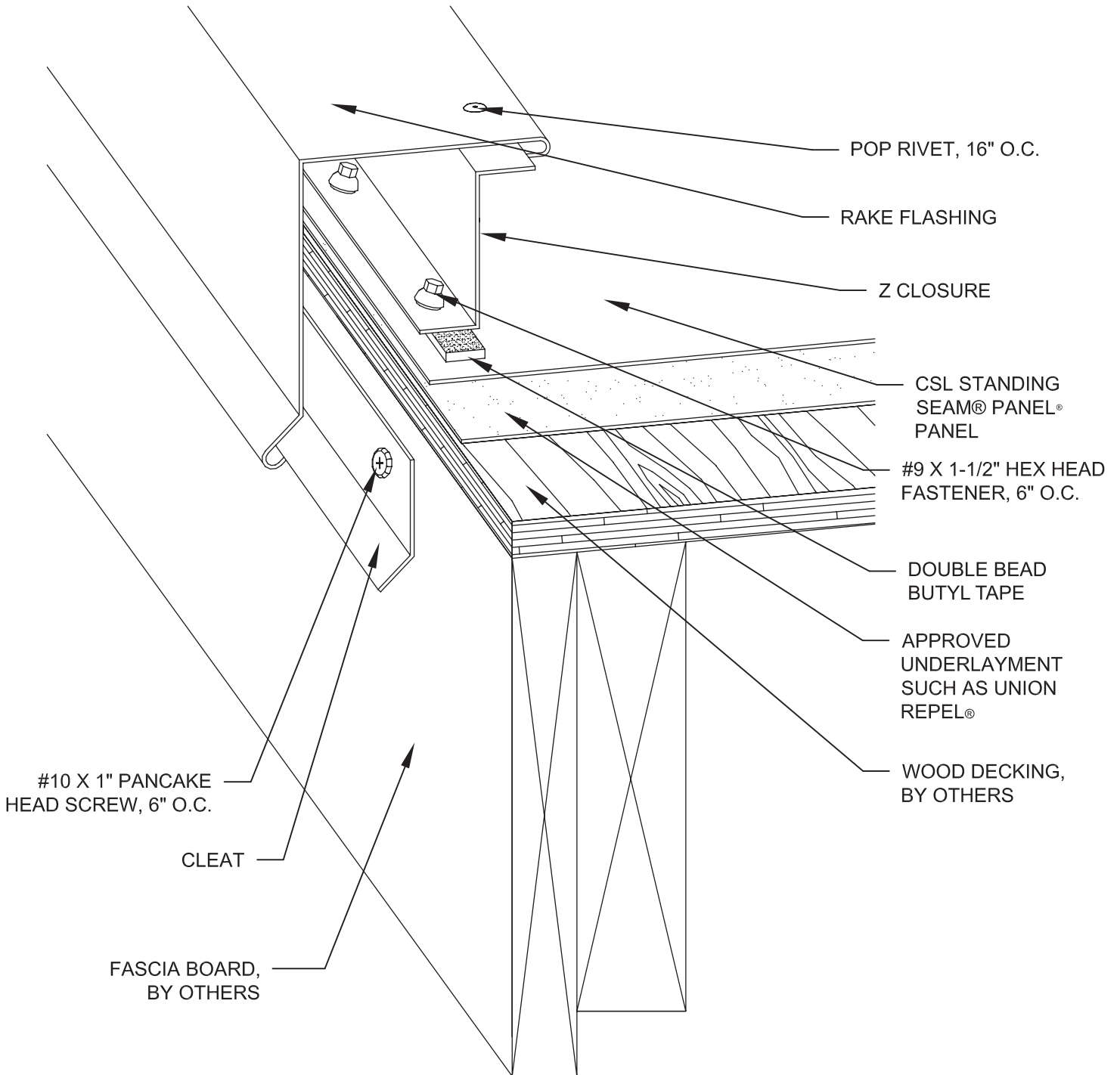

## VALLEY

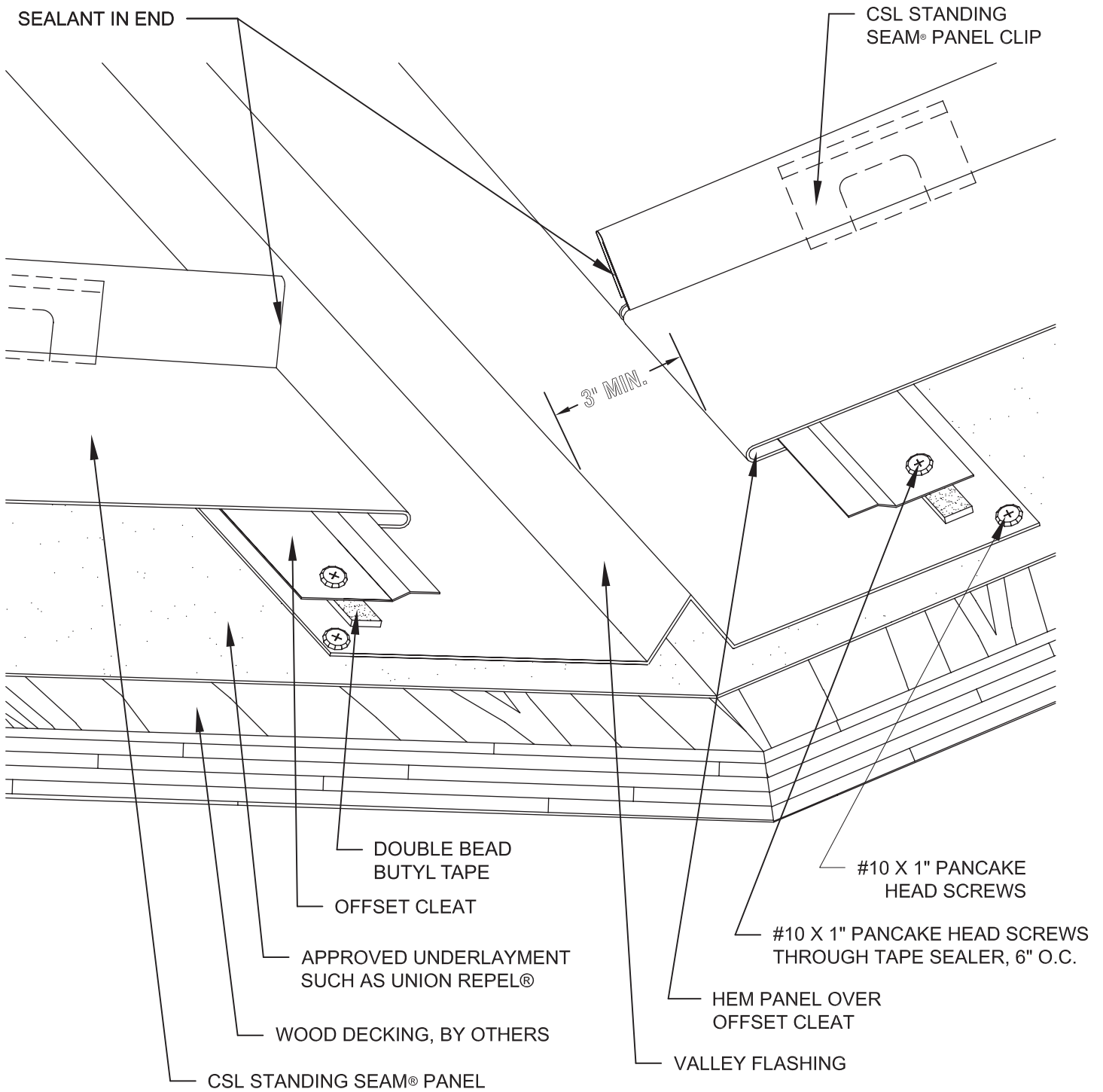

## SIDE WALL

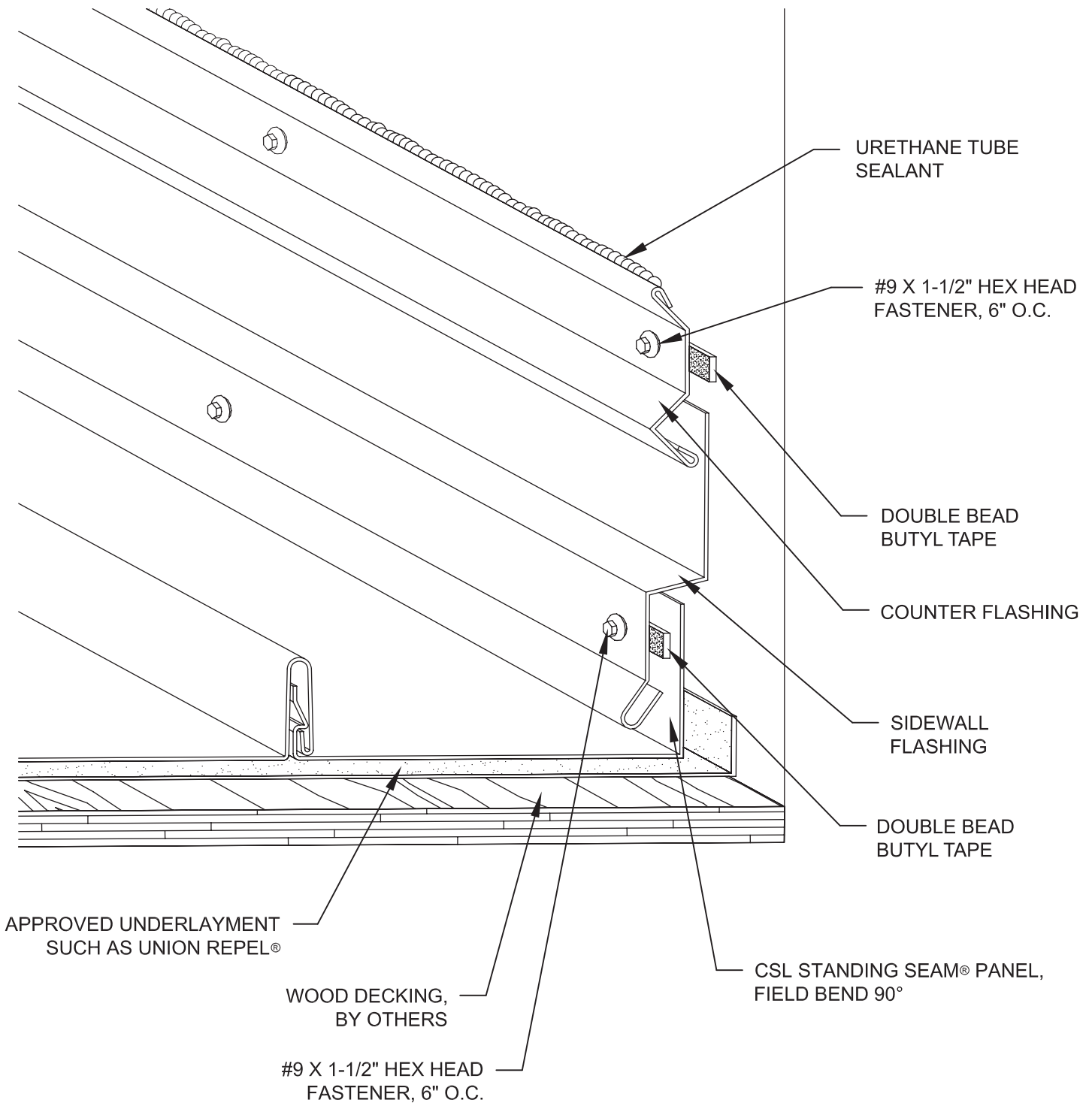

## END WALL

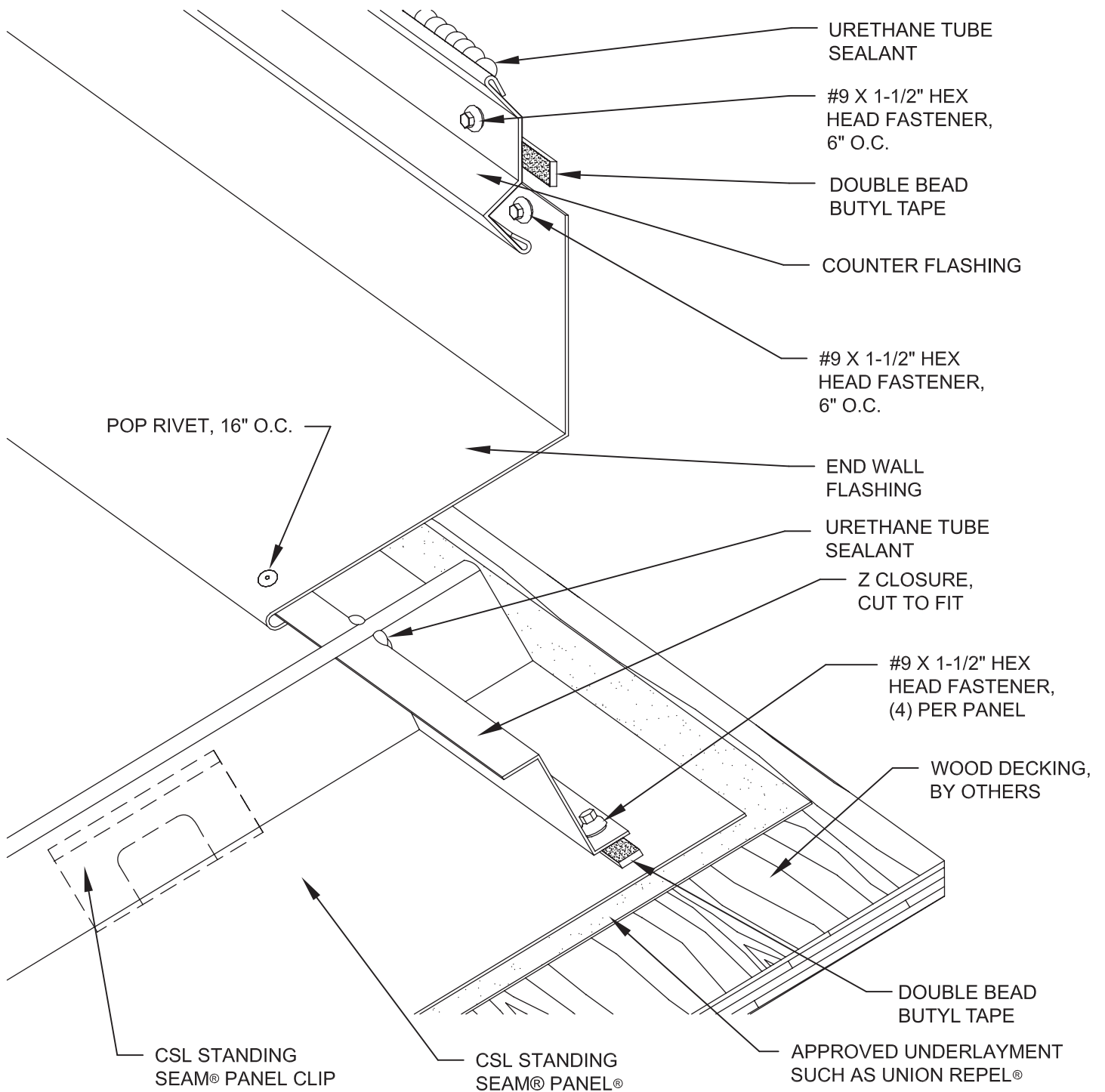

## TRANSITION

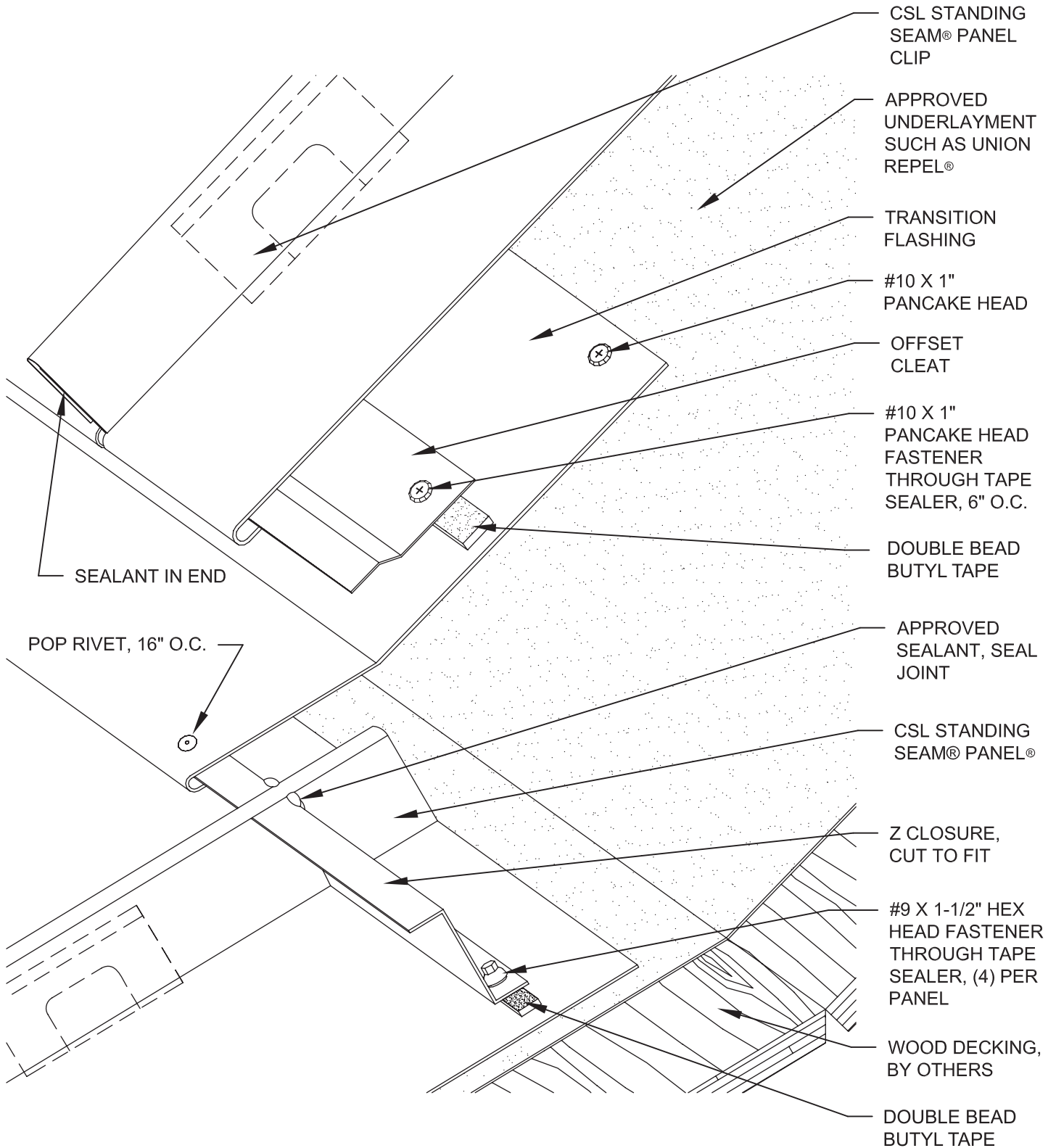



## MANSARD TRANSITION

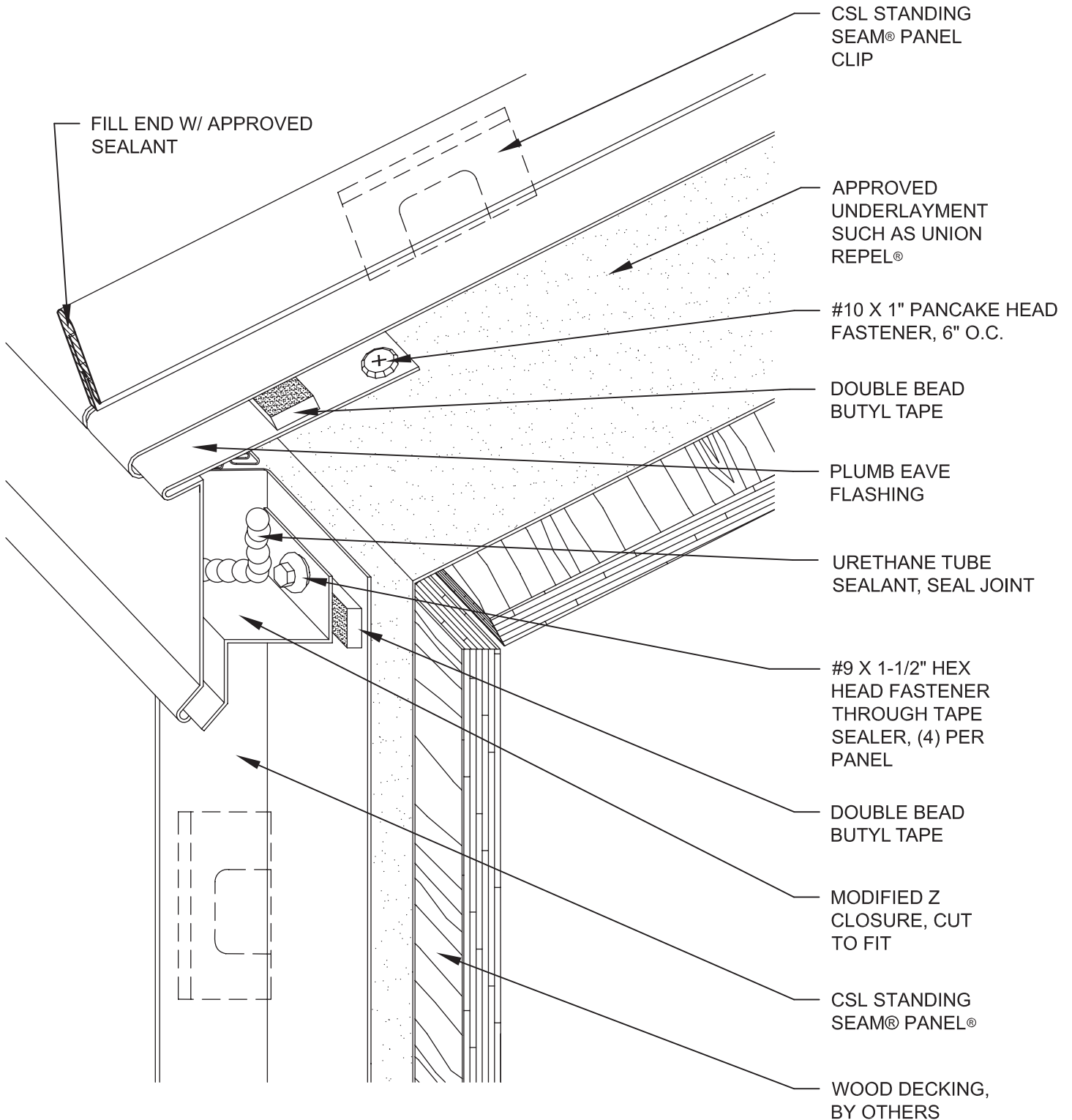



---

P.O. Box 229 • Fayetteville, NC 28302 • 910-483-2195 • FAX: 910-483-1091

SPENCER STEEL SUPPLY  
SPENCER, NC

ANDERSON STEEL SUPPLY  
ANDERSON, SC

ORANGE STEEL ROOFING  
ORANGE, VA

TIFTON STEEL PRODUCTS  
TIFTON, GA

UNICO METAL PRODUCTS  
OCALA, FL

VICKSBURG METAL PRODUCTS  
VICKSBURG, MS

DAYTON METALS  
PIQUA, OH

GREAT PLAINS METALS  
YUKON, OK

NORTHEAST DIVISION  
OLYPHANT, PA